

Hunter®

2013 PRODUCT CATALOG

RESIDENTIAL & COMMERCIAL IRRIGATION | *Built on Innovation*



WE'RE INNOVATING MORE, SO YOU CAN CONTINUE TO USE LESS.

We believe a [healthy landscape](#) and water conservation can be one and the same. By coupling our engineering expertise with our cultural belief of minimizing environmental impact, we can meet our goal of reducing natural resource use. It's not only good for the planet, it's smart for your business.

Implementing innovative products such as Eco-Mat, MP Rotator or Solar Sync into your project will allow you to achieve the beautiful results your clients demand with the ecological benefit of efficient water use. These are just some of the forward thinking examples of eco-innovation at work.

[eco](#)innovation





FXLuminaire.

Endless possibilities, ULTIMATE LED EFFICIENCY

Creating the perfect ambiance for the perfect evening is an art that requires precision and expertise. FX Luminaire combines cutting-edge engineering, LED technology, and unmatched technical support to help lighting professionals turn any vision into reality.

From the all-new Luxor[®]ZD™ controller with complete zoning and dimming capabilities, to our robust line of hand-crafted fixtures built to withstand the harshest environments, the FX brand is poised to lead the way for a better future in landscape lighting.

WHAT'S NEW

MP ROTATOR

55

MP3500

Offering an innovative way to irrigate out to 35 feet, Hunter's MP3500 utilizes multi-stream, multi-trajectory technology to precisely lay down water at the exact location, which dramatically increases system efficiency.



CONTROLLERS

77

PRO-C/FX

The Pro-C now has the ability to control irrigation and lighting schedules from a single controller with a simple facepack upgrade.



CONTROLLERS

86

ROAM XL

Remotely access any Hunter SmartPort controller from up to two miles away. Perfect for large-scale commercial and municipal sites.



ROTORS

- 12 Advanced Features
- 13 PGJ
- 14 SRM
- 15 PGP®
- 17 PGP Ultra
- 19 I-20
- 21 I-25
- 23 I-40
- 25 I-60
- 27 I-90
- 29 ST System

SPRAYS

- 36 Advanced Features
- 37 PS Ultra
- 39 Pro-Spray®
- 40 PRS30
- 41 PRS40

NOZZLES

- 43 Pro Adjustable Nozzles
- 46 Pro-Spray® Fixed Arc Nozzles
- 49 Short Radius Nozzles
- 50 Strip Pattern Nozzles
- 51 Stream Nozzles
- 52 Bubbler Nozzles
- 53 Bubblers

MP ROTATOR

- 55 MP Rotator®

VALVES

- 61 Advanced Features
- 62 SRV
- 63 PGV
- 64 PGV Jar Top
- 65 PGV-ASV
- 66 ICV
- 67 IBV
- 68 Accu-Sync™
- 69 Quick Couplers

CONTROLLERS

- 73 Advanced Features
- 75 X-Core
- 76 XC Hybrid
- 77 PCC
- 78 Pro-C
- 79 I-Core
- 80 Dual
- 81 ACC
- 82 ACC-99D
- 83 ICD-HP
- 84 PSR
- 85 Roam
- 86 Roam XL
- 87 Node
- 88 WVP & WVC

TABLE OF CONTENTS

CONTROLLERS

87

Solar Panel for Node & XC Hybrid Controllers

A highly innovative solution for irrigation zone control, the new Solar Panel option for Node and XC Hybrid controllers harnesses the power of the sun to promote a healthier environment.

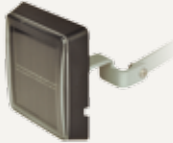

MICRO

107

ECO-MAT

Eco-Mat couples Hunter's Professional Landscape Dripline with special fleece wrapping and fleece matting to ensure efficient and uniform subsurface irrigation.



MICRO

109

PLD-ESD

Hunter's PLD-ESD (Enhanced Subsurface Dripline) adds fleece wrapping to traditional inline emitter tubing to aid uniform water movement in subsurface installations.



CENTRAL

- 90 Advanced Features
- 91 IMMS

SENSORS

- 97 Solar Sync™
- 98 ET System
- 99 Rain-Clik™
- 100 Mini-Clik®
- 101 Mini Weather Station
- 101 Wind-Clik™
- 102 Flow-Clik™
- 103 Flow-Sync™
- 104 Freeze-Clik®

MICRO

- 107 Eco-Mat
- 109 PLD
- 110 Micro Sprays
- 111 Drip Zone Control Kits
- 112 RZWS

ACCESSORIES

- 115 Accessories
- 117 Tools

TECHNICAL INFORMATION

- 121 Replacement Guide
- 125 Precipitation Rates
- 126 Slope Equivalents/Irrigation
- 127 Height of Spray
- 129 17 mm PLD Charts
- 130 Drip Control Zone Kit Charts
- 131 Conversion Factors
- 132 Friction Loss Charts
- 142 Wire Data
- 143 Wire Sizing
- 144 Additional Data

STATEMENT OF WARRANTY

Blueprint of an EFFICIENT IRRIGATION SYSTEM

A properly designed, managed, and maintained irrigation system is an essential tool for a healthy, functional landscape. The Hunter products featured here will maximize the effectiveness of the water you use.

A PGP® Ultra & I-20

Hunter rotors are the best choice when watering a large turf or landscape area. Our nozzles are engineered for excellent water distribution at low precipitation rates to keep a landscape looking its best, while still using water efficiently.

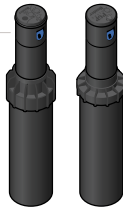

B Pro-Spray® & Nozzles

Smaller areas require spray sprinklers for proper watering. Hunter's spray bodies are available with pressure regulation to ensure the most accurate watering of any landscape. Hunter's spray nozzles are meticulously engineered and tested to provide even watering and efficient use.

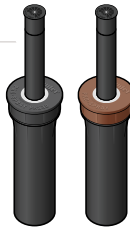

C MP Rotator®

The ultimate solution for small- to medium-sized areas, this high-efficiency, low precipitation rate sprinkler offers unmatched performance and proven water savings up to 30% over sprays.

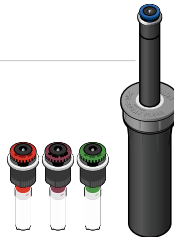

D PGV, ICV, & Drip Control Kits

Hunter's trusted valve line ensures system reliability and accuracy. Accu-Sync can be used on systems with excess pressure to extend the life of the system components and provide the correct operating pressure to the sprinklers. Drip zone kits are equipped with pressure regulators and filters to provide drip and micro irrigation components with the correct pressure and contaminant-free water.

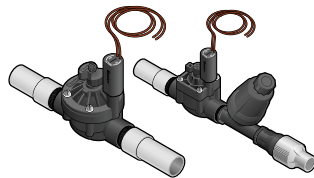

E Drip/Micro Irrigation

Drip irrigation is an efficient choice for certain landscape situations. It applies water directly to the root zone area of landscape plants, helping to limit excess irrigation. Micro spray emitters can be used to cover small planting beds efficiently.

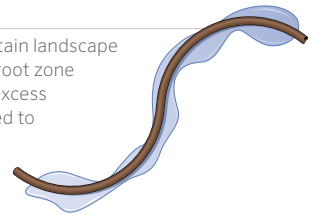

F Pro-C/I-Core

The correct controller for the job is essential to meet the needs of any landscape, from unpredictable weather to municipal watering requirements. Having a customizable controller that is sensor compatible is the first step to a water-efficient system.

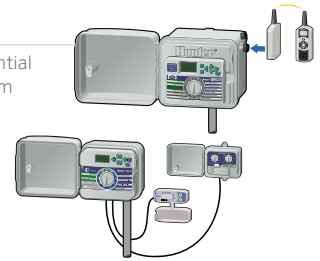

G Flow-Click/Flow-Sync™

Flow sensors prevent systems from running when there is a leak or broken component. The Flow-Click will work with most Hunter controllers to suspend irrigation, and the Flow-Sync is compatible with specific Hunter controllers to monitor overflow and provide flow totaling for better management.

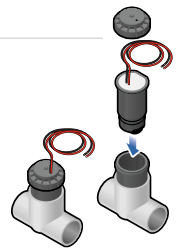





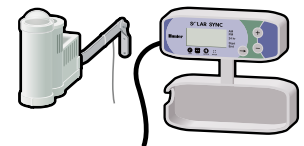

H Solar Sync™

Solar Sync monitors weather, working with the controller to adjust the system for changing conditions, ensuring water is not wasted.

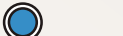



LEGEND

-  Spray Heads
-  Rotors
-  MP Rotators
-  Control Valves
-  Landscape Dripline
-  Weather Sensor
-  Flow Sensor
-  Controller

ROTORS

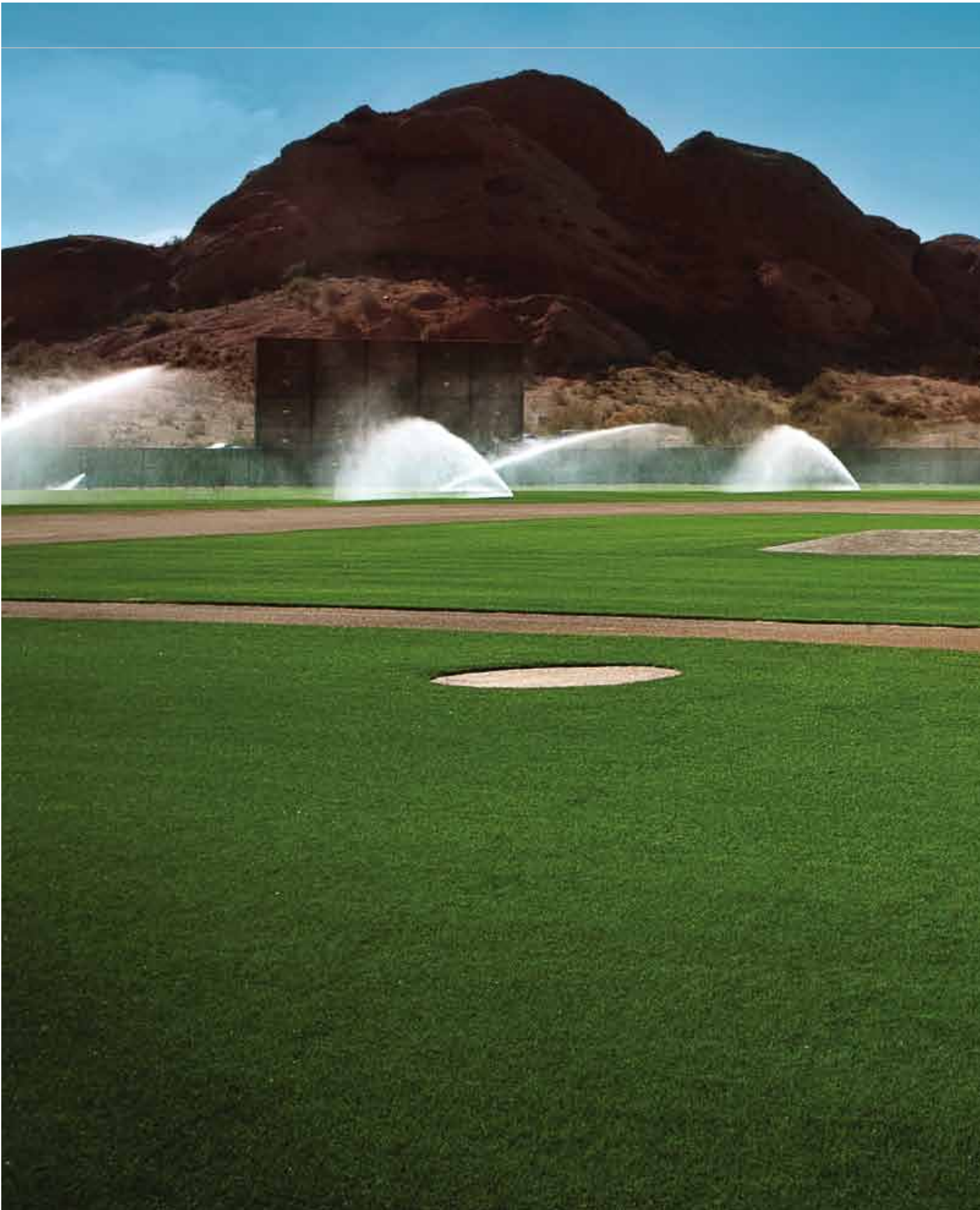

ROTORS

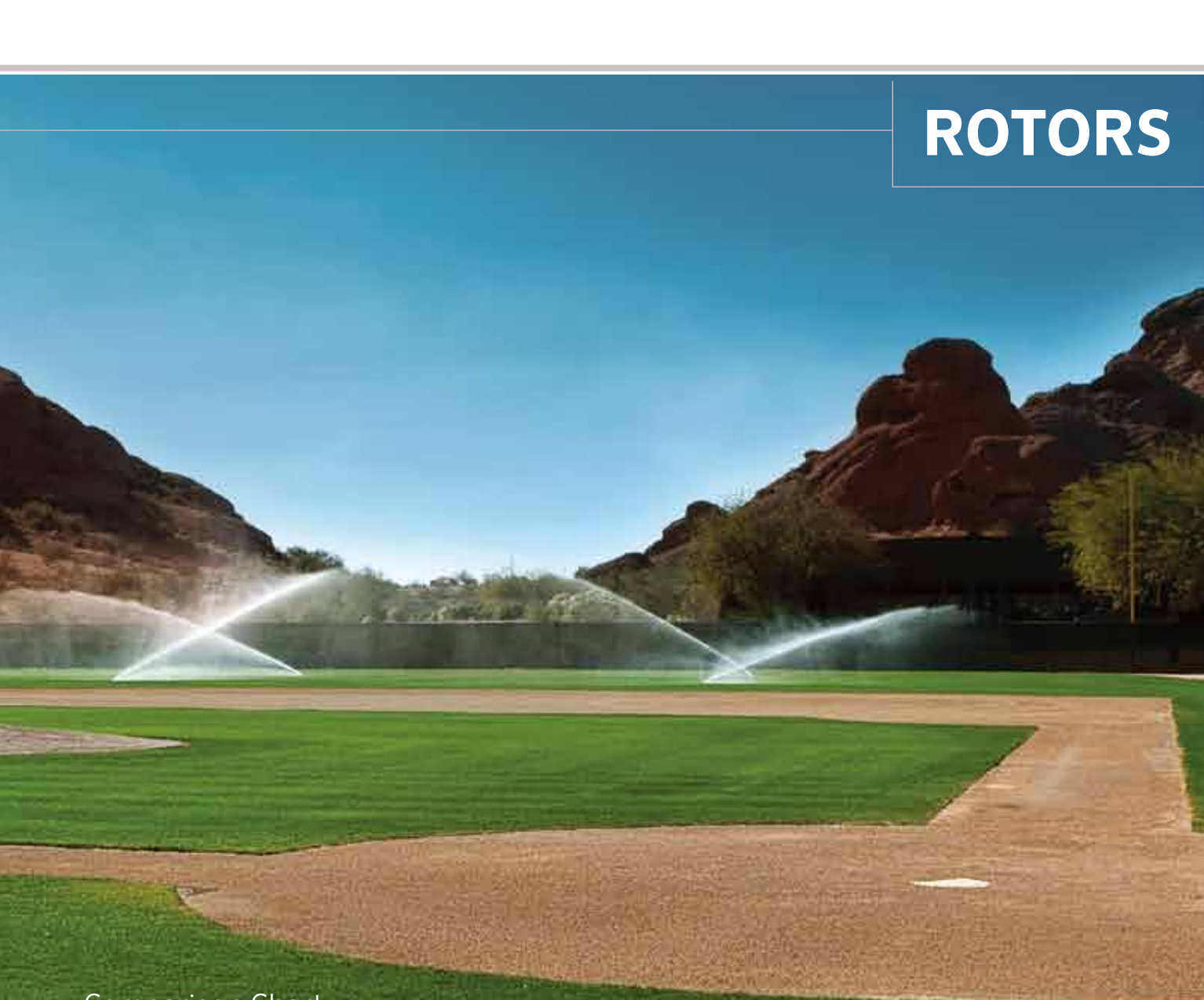

Comparison Chart

	PGJ	SRM	PGP®	PGP ULTRA	I-20	I-25	I-40	I-60	I-90	ST SYSTEM
APPLICATIONS										
Spacings 15' to 37'	•	•		•	•					
Spacings 25' to 45'			•	•	•					
Spacings more than 45'						•	•	•	•	•
Residential	•	•	•	•	•					
Commercial/Institutional				•	•	•	•	•	•	
Athletic fields					•	•	•		•	•
High vandalism areas				•	•	•	•		•	
Low pressure systems	•	•	•	•				•		
Riser-mounted sprinklers	•			•	•					•
Ground cover and/or shrubs	•		•	•	•					
Reclaimed water ID cover	•			•	•	•	•	•	•	

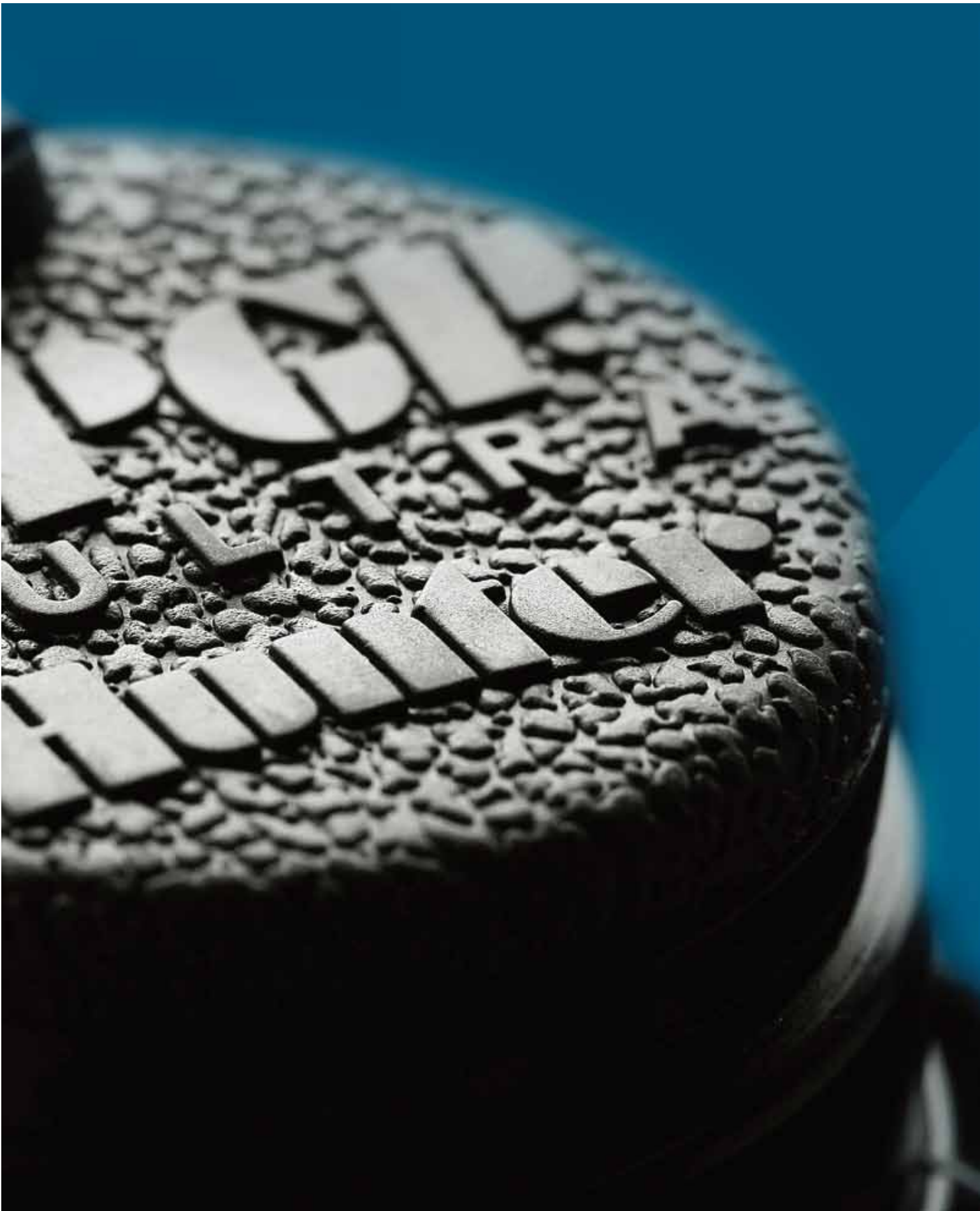

ADVANCED FEATURES

Automatic Arc Return

This patented feature returns to the original arc regardless of where the turret is turned. This ensures vandal protection in any environment.

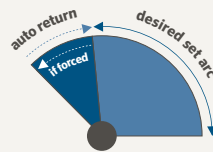

PGP Ultra, I-20, I-25, I-40

Reclaimed Water ID

Purple caps indicate where non-potable irrigation water is being used.

PGJ, PGP Ultra, I-20, I-25, I-40, I-60, I-90



Stainless Steel Riser

For unforgiving soil conditions, unpredictable climates, or heavy foot traffic, stainless steel is the best choice.

Standard on I-40 and I-60
Optional on I-20 and I-25



Non-Strippable Drive

The patented, non-strippable, vandal proof drive mechanism enables the turret to be turned without causing damage.

PGP Ultra, I-20, I-25, I-40



FloStop™ Control

FloStop closes the flow of water from individual sprinkler heads while the system is running. This is ideal for changing nozzles or turning off specific heads during maintenance and construction.

I-20



Part- and Full-Circle In One Model

Patented non-reversing 360 for part- and full-circle in one model, from 50 to 360 degrees.

PGP Ultra, I-20, I-25, I-40

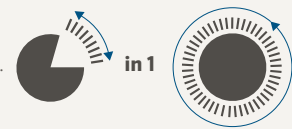

Headed and Slotted Set Screw

Use a slotted screwdriver or the Hunter wrench for easier and simpler adjustments as needed.

PGJ, PGP Ultra, I-20



Color Coded Nozzles

Nozzles are easier to differentiate in the field for simple installation and quick organization.

I-25, I-40, I-60, I-90



Drain Check Valve

The drain check valve keeps lines from draining when the system is shut off. This saves water, reduces liability, and increases system life.

PGJ, PGP Ultra, I-20, I-25, I-40, I-60, I-90



Opposing Nozzle 360° Model

The opposing nozzle design offers excellent water distribution. With primary and secondary nozzles on opposing sides of the turret, streams arc in opposite directions as the sprinkler rotates for outstanding midrange and close-in watering.

I-40, I-90



PGJ

Application: **Residential**
 Radius: **15' to 37'**
 Flow Rate: **0.64 - 5.3 GPM**
 Inlet Size: **½" NPT**

FEATURES

- Models: Shrub, 4", 6", 12"
- Arc setting: 40 to 360 degrees
- Nozzle choices: 8
- Nozzle range: 0.75 to 5.0
- Standard factory installed nozzle: 2.0 only
- Factory installed rubber cover
- Through-the-top arc adjustment
- Quick check arc mechanism
- Water lubricated gear-drive
- Warranty period: 2 years
- ▶ Headed and slotted set screw
- ▶ Reclaimed water ID
- ▶ Drain check valve (Up to 7' of elevation)

OPERATING SPECIFICATIONS

- Radius: 15' to 37'
- Flow rate: 0.64 to 5.3 GPM
- Recommended pressure range: 30 to 50 PSI
- Operating pressure range: 20 to 100 PSI
- Precipitation rates: 0.6 in/hr approx.
- Nozzle trajectory: 14 degrees approx.

▶ = Advanced Feature descriptions on page 12



PGJ Reclaimed
 Available as a factory-installed option on all models

PGJ - SPECIFICATION BUILDER: ORDER 1 + 2 + 3		
1 Model	2 Standard Features	3 Feature Options
PGJ-00 = Shrub	Adjustable arc, 8 standard nozzles	(blank) = No option
PGJ-04 = 4" Pop-up		V = Drain check valve
PGJ-06 = 6" Pop-up		R = Drain check valve and reclaimed water ID
PGJ-12 = 12" Pop-up		

Examples:
 PGJ-04 = 4" pop-up, adjustable arc
 PGJ-06 - V = 6" pop-up, adjustable arc, with drain check valve
 PGJ-12 - R = 12" pop-up, adjustable arc, with drain check valve and reclaimed water ID



PGJ NOZZLE PERFORMANCE DATA					
Nozzle	Pressure (PSI)	Radius (FT.)	Flow (GPM)	Precip in/hr ■	Precip in/hr ▲
.75 ●	30	15	0.64	0.55	0.63
	40	16	0.75	0.56	0.65
Red	50	17	0.85	0.57	0.65
1.0 ●	30	18	0.85	0.51	0.58
	40	19	1.0	0.53	0.62
Red	50	19	1.1	0.59	0.68
1.5 ●	30	21	1.3	0.57	0.66
	40	22	1.5	0.60	0.69
Red	50	22	1.7	0.68	0.78
2.0 ●	30	24	1.7	0.57	0.66
	40	25	2.0	0.62	0.71
Red	50	25	2.3	0.71	0.82
2.5 ●	30	27	2.2	0.58	0.67
	40	28	2.5	0.61	0.71
Red	50	28	2.8	0.69	0.79
3.0 ●	30	30	2.5	0.53	0.62
	40	31	3.0	0.60	0.69
Red	50	31	3.4	0.68	0.79
4.0 ●	30	33	3.7	0.65	0.76
	40	34	4.0	0.67	0.77
Red	50	34	4.3	0.72	0.83
5.0 ●	30	36	4.7	0.70	0.81
	40	37	5.0	0.70	0.81
Red	50	37	5.3	0.75	0.86

Bold = Recommended pressure

Notes:
 All precipitation rates calculated for 180 degree operation. For the precipitation rate for a 360 degree sprinkler, divide by 2.

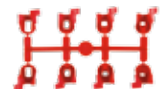

SRM

Application: **Residential**
 Radius: **15' to 30'**
 Flow Rate: **0.42 to 3.4 GPM**
 Inlet Size: **½" NPT**

FEATURES

- Model: 4"
- Arc setting: 40 to 360 degrees
- Nozzle choices: 6
- Nozzle range: 0.50 to 3.0
- Standard factory installed nozzle: 3.0 only
- Through-the-top arc adjustment
- Quick check arc mechanism
- Water lubricated gear-drive
- Warranty period: 1 year

OPERATING SPECIFICATIONS

- Radius: 15' to 30'
- Flow rate: 0.42 to 3.4 GPM
- Recommended pressure range: 30 to 50 PSI
- Operating pressure range: 20 to 100 PSI
- Precipitation rates: 0.45 in/hr approx.
- Nozzle trajectory: 18 degrees approx.



SRM-04
 Overall height: 6¾"
 Pop-up height: 4"
 Exposed diameter: 1½"
 Inlet size: ½" female NPT

ROTORS

SRM	
Model	Description
SRM-04	4" Pop-up, adjustable arc, 6 standard nozzles

SRM NOZZLE PERFORMANCE DATA

Nozzle	Pressure (PSI)	Radius (FT.)	Flow (GPM)	Precip in/hr	
				■	▲
.50 ● Dk. Green	30	15	0.42	0.36	0.41
	40	16	0.50	0.38	0.43
	50	17	0.58	0.39	0.45
.75 ● Dk. Green	30	15	0.42	0.36	0.41
	40	16	0.50	0.38	0.43
	50	17	0.58	0.39	0.45
1.0 ● Dk. Green	30	19	0.85	0.45	0.52
	40	20	1.0	0.48	0.56
	50	20	1.1	0.53	0.61
1.5 ● Dk. Green	30	23	1.3	0.47	0.55
	40	24	1.5	0.50	0.58
	50	25	1.7	0.52	0.60
2.0 ● Dk. Green	30	25	1.7	0.52	0.60
	40	26	2.0	0.57	0.66
	50	27	2.3	0.61	0.70
3.0 ● Dk. Green	30	28	2.5	0.61	0.71
	40	30	3.0	0.64	0.74
	50	30	3.4	0.73	0.84

Bold = Recommended pressure

Notes:

All precipitation rates calculated for 180 degree operation. For the precipitation rate for a 360 degree sprinkler, divide by 2.





Application: Residential
Radius: 22' to 52'
Flow Rate: 0.5 to 14.1 GPM
Inlet Size: 3/4" NPT

FEATURES

- Model: 4"
- Arc setting: 40 to 360 degrees
- Factory installed rubber cover
- Through-the-top arc adjustment
- Quick check arc mechanism
- Water lubricated gear-drive
- Nozzle choices: 27 total
- Nozzle racks: Red, Blue, Grey Low Angle
- Warranty period: 2 years

OPERATING SPECIFICATIONS

- Radius: 22' to 52'
- Flow rate: 0.5 to 14.1 GPM
- Recommended pressure range: 25 to 70 PSI
- Operating pressure range: 20 to 100 PSI
- Precipitation rates: 0.4 in/hr approx.
- Nozzle trajectory: Std = 25 degrees, Low angle = 13 degrees



PGP-ADJ
 Overall height: 7 3/8"
 Pop-up height: 4"
 Exposed diameter: 1 3/4"
 Inlet size: 3/4" female NPT



PGP-ATR
 Advanced Technology
 Replacement for impact rotors



PGP-ADJ
 Easy arc and radius adjustment

PGP GRAY LOW ANGLE NOZZLE PERFORMANCE DATA

Nozzle	Pressure (PSI)	Radius (FT.)	Flow (GPM)	Precip in/hr	
				■	▲
4LA ●	30	22	1.4	0.56	0.64
	40	24	1.7	0.57	0.66
	Gray 50	26	1.8	0.51	0.59
	60	28	2.0	0.49	0.57
5LA ●	30	25	1.6	0.49	0.57
	40	27	1.9	0.50	0.58
	Gray 50	28	2.1	0.52	0.60
	60	30	2.3	0.49	0.57
6LA ●	30	27	2.1	0.55	0.64
	40	30	2.5	0.53	0.62
	Gray 50	33	2.8	0.49	0.57
	60	35	3.0	0.47	0.54
7LA ●	30	29	2.8	0.64	0.74
	40	32	3.1	0.58	0.67
	Gray 50	35	3.5	0.55	0.64
	60	37	3.8	0.53	0.62
8LA ●	30	31	3.4	0.68	0.79
	40	34	3.9	0.65	0.75
	Gray 50	37	4.4	0.62	0.71
	60	38	4.7	0.63	0.72
9LA ●	30	33	4.3	0.76	0.88
	40	37	5.0	0.70	0.81
	Gray 50	40	5.6	0.67	0.78
	60	42	6.1	0.67	0.77
10LA ●	40	38	6.5	0.87	1.00
	50	40	7.3	0.88	1.01
	Gray 60	42	8.0	0.87	1.01
	70	44	8.6	0.86	0.99

Bold = Recommended pressure

Notes:

All precipitation rates calculated for 180 degree operation. For the precipitation rate for a 360 degree sprinkler, divide by 2.

PGP-ADJ – SPECIFICATION BUILDER: ORDER 1 + 2 + 3

1 Model	2 Standard Features	3 Feature Options
PGP-ADJ-B = 4" Pop-up	Adjustable arc with Blue nozzle rack	(blank) = No option
PGP-ADJ = 4" Pop-up	Adjustable arc with Red nozzle rack	1.5 to 4.0 = Factory-installed Blue nozzle number
PGP-ATR = Impact replacement	Adjustable arc with Red nozzle rack	#5 to #8 = Factory-installed Red nozzle number #7 = Factory-installed Red nozzle number

Examples:

- PGP-ADJ = 4" pop-up, adjustable arc
- PGP-ADJ-B - 3.0 = 4" pop-up, adjustable arc, and 3.0 Blue nozzle
- PGP-ADJ - 07 = 4" pop-up, adjustable arc, and #7 Red nozzle

PGP RED NOZZLE PERFORMANCE DATA					
Nozzle	Pressure (PSI)	Radius (FT.)	Flow (GPM)	Precip in/hr	
				■	▲
1 ● Red	30	28	0.5	0.12	0.14
	40	29	0.6	0.14	0.16
	50	29	0.7	0.16	0.19
	60	30	0.8	0.17	0.20
2 ● Red	30	29	0.7	0.16	0.19
	40	30	0.8	0.17	0.20
	50	30	0.9	0.19	0.22
	60	31	1.0	0.20	0.23
3 ● Red	30	30	0.9	0.19	0.22
	40	31	1.0	0.20	0.23
	50	31	1.2	0.24	0.28
	60	32	1.3	0.24	0.28
4 ● Red	30	32	1.2	0.23	0.26
	40	33	1.4	0.25	0.29
	50	34	1.6	0.27	0.31
	60	34	1.8	0.30	0.35
5 ● Red	30	32	1.6	0.30	0.35
	40	36	1.8	0.27	0.31
	50	38	2.0	0.27	0.31
	60	38	2.2	0.29	0.34
6 ● Red	30	34	2.0	0.33	0.38
	40	36	2.4	0.36	0.41
	50	38	2.7	0.36	0.42
	60	38	2.9	0.39	0.45
7 ● Red	30	34	2.6	0.43	0.5
	40	38	3.0	0.40	0.46
	50	40	3.4	0.41	0.47
	60	40	3.7	0.45	0.51
8 ● Red	30	37	3.2	0.45	0.52
	40	39	3.7	0.47	0.54
	50	41	3.9	0.45	0.52
	60	42	4.6	0.50	0.58
9 ● Red	30	38	3.6	0.48	0.55
	40	41	4.3	0.49	0.57
	50	44	5.2	0.52	0.60
	60	45	5.5	0.52	0.60
10 ● Red	40	44	6.0	0.60	0.69
	50	46	6.8	0.62	0.71
	60	47	7.6	0.66	0.76
	70	49	8.2	0.66	0.76
11 ● Red	40	46	8.0	0.73	0.84
	50	48	8.9	0.74	0.86
	60	50	9.8	0.75	0.87
	70	51	10.5	0.78	0.90
12 ● Red	40	46	10.5	0.96	1.10
	50	48	11.9	0.99	1.15
	60	50	12.7	0.98	1.13
	70	52	14.1	1.00	1.16

Bold = Recommended pressure

Notes:

All precipitation rates calculated for 180 degree operation. For the precipitation rate for a 360 degree sprinkler, divide by 2.

PGP BLUE NOZZLE PERFORMANCE DATA					
Nozzle	Pressure (PSI)	Radius (FT.)	Flow (GPM)	Precip in/hr	
				■	▲
1.5 ● Blue	25	29	1.2	0.27	0.32
	35	31	1.4	0.28	0.32
	45	31	1.5	0.30	0.35
	55	32	1.8	0.34	0.39
2.0 ● Blue	25	33	1.4	0.25	0.29
	35	33	1.7	0.30	0.35
	45	34	2.0	0.33	0.38
	55	34	2.1	0.35	0.40
2.5 ● Blue	25	33	1.7	0.30	0.35
	35	35	2.1	0.33	0.38
	45	35	2.5	0.39	0.45
	55	35	2.6	0.41	0.47
3.0 ● Blue	25	35	2.2	0.35	0.40
	35	36	2.7	0.40	0.46
	45	38	3.0	0.40	0.46
	55	39	3.4	0.43	0.50
4.0 ● Blue	25	37	3.0	0.42	0.49
	35	39	3.5	0.44	0.51
	45	40	4.0	0.48	0.56
	55	41	4.5	0.52	0.60
5.0 ● Blue	25	37	3.7	0.52	0.60
	35	39	4.5	0.57	0.66
	45	42	5.0	0.55	0.63
	55	42	5.7	0.62	0.72
6.0 ● Blue	25	38	4.3	0.57	0.66
	35	40	5.6	0.67	0.78
	45	43	6.0	0.62	0.72
	55	44	6.7	0.67	0.77
8.0 ● Blue	25	37	6.0	0.84	0.97
	35	41	7.0	0.80	0.93
	45	44	8.0	0.80	0.92
	55	46	9.0	0.82	0.95
65	46	9.8	0.89	1.03	

PGP NOZZLES



Red (P/N 130900)



Blue (P/N 665300)



Gray (P/N 233200)

PGP® ULTRA

Application: **Residential/Commercial**
 Radius: **17' to 47'**
 Flow Rate: **0.36 to 14.8 GPM**
 Inlet Size: **¾" NPT**

FEATURES

- Models: Shrub, 4", 12"
- Arc setting: 50 to 360 degrees
- Factory installed rubber cover
- Through-the-top arc adjustment
- Quick check arc mechanism
- Water lubricated gear-drive
- Nozzle choices: 22
- Nozzle racks: 1.5 to 8.0 blue, 2.0 LA to 4.5 LA grey, 0.50 to 3.0 black, 6.0 to 13.0 green
- Warranty period: 5 years
- ▶ Automatic arc return
- ▶ Non-strippable drive
- ▶ Part- and full-circle in one model
- ▶ Headed and slotted set screw
- ▶ Reclaimed water ID
- ▶ Drain check valve (Up to 10' of elevation)

OPERATING SPECIFICATIONS

- Radius: 17' to 47'
- Flow rate: 0.36 to 14.8 GPM
- Recommended pressure range: 25 to 70 PSI
- Operating pressure range: 20 to 100 PSI
- Precipitation rates: 0.4 in/hr approx.
- Nozzle trajectory: Std = 25 degrees, Low angle = 13 degrees

▶ = Advanced Feature descriptions on page 12



PGP Ultra Reclaimed
 Available as a factory-installed option on all models



PGP Ultra
 Easy arc and radius adjustment



PGP-00
 Overall height: 7½"
 Exposed diameter: 1¾"
 Inlet size: ¾" female NPT



PGP-04
 Overall height: 7½"
 Pop-up height: 4"
 Exposed diameter: 1¾"
 Inlet size: ¾" female NPT



PGP-12
 Overall height: 17"
 Pop-up height: 12"
 Exposed diameter: 1¾"
 Inlet size: ¾" female NPT

PGP-ULTRA – SPECIFICATION BUILDER: ORDER 1 + 2 + 3 + 4

1 Models	2 Standard Features	3 Feature Options	4 Nozzle Options
PGP-00 = Shrub PGP-04 = 4" Pop-up PGP-12 = 12" Pop-up	Adjustable arc, plastic riser, 8 standard nozzles, and 4 low-angle nozzles	(blank) = No option CV = Drain check valve CV-R = Drain check valve and reclaimed water ID	1.5 to 4.0 = Factory installed nozzle number

Examples:
 PGP-04 = 4" pop-up, adjustable arc
 PGP-04 - 2.5 = 4" pop-up, adjustable arc, and 2.5 nozzle
 PGP-12 - CV-R - 4.0 = 12" pop-up, adjustable arc, with drain check valve and reclaimed water ID

ROTORS

PGP ULTRA BLUE STANDARD NOZZLE PERFORMANCE DATA

Nozzle	Pressure (PSI)	Radius (FT.)	Flow (GPM)	Precip in/hr	
				■	▲
1.5 Blue	25	29	1.2	0.27	0.32
	35	31	1.4	0.28	0.32
	45	31	1.5	0.30	0.35
	55	32	1.8	0.34	0.39
	65	32	1.9	0.36	0.41
2.0 Blue	25	33	1.4	0.25	0.29
	35	33	1.7	0.30	0.35
	45	34	2.0	0.33	0.38
	55	34	2.1	0.35	0.40
	65	32	2.3	0.43	0.50
2.5 Blue	25	33	1.7	0.30	0.35
	35	35	2.1	0.33	0.38
	45	35	2.5	0.39	0.45
	55	35	2.6	0.41	0.47
	65	35	2.9	0.46	0.53
3.0 Blue	25	35	2.2	0.35	0.40
	35	36	2.7	0.40	0.46
	45	38	3.0	0.40	0.46
	55	39	3.4	0.43	0.50
	65	39	3.7	0.47	0.54
4.0 Blue	25	37	3.0	0.42	0.49
	35	39	3.5	0.44	0.51
	45	40	4.0	0.48	0.56
	55	41	4.5	0.52	0.60
	65	41	4.8	0.55	0.63
5.0 Blue	25	37	3.7	0.52	0.60
	35	39	4.5	0.57	0.66
	45	42	5.0	0.55	0.63
	55	42	5.7	0.62	0.72
	65	42	6.2	0.68	0.78
6.0 Blue	25	38	4.3	0.57	0.66
	35	40	5.6	0.67	0.78
	45	43	6.0	0.62	0.72
	55	44	6.7	0.67	0.77
	65	44	7.3	0.73	0.84
8.0 Blue	25	37	6.0	0.84	0.97
	35	41	7.0	0.80	0.93
	45	44	8.0	0.80	0.92
	55	46	9.0	0.82	0.95
	65	46	9.8	0.89	1.03

PGP ULTRA HIGH FLOW NOZZLE PERFORMANCE DATA

Nozzle	Pressure (PSI)	Radius (FT.)	Flow (GPM)	Precip in/hr	
				■	▲
10 Dk. Green	40	42	8.4	0.92	1.06
	50	43	9.5	0.99	1.14
	60	45	10.5	1.00	1.15
	70	47	11.4	0.99	1.15
13 Dk. Green	40	43	10.9	1.13	1.31
	50	44	12.3	1.22	1.41
	60	45	13.6	1.29	1.49
	70	47	14.8	1.29	1.49
6.0 LA Dk. Green	30	31	4.2	0.84	0.97
	40	35	5.0	0.79	0.91
	50	37	5.8	0.82	0.94
8.0 LA Dk. Green	60	39	6.3	0.80	0.92
	40	37	6.7	0.94	1.09
	50	39	7.7	0.97	1.13
	60	41	8.5	0.97	1.12
Dk. Green	70	41	9.2	1.05	1.22

PGP ULTRA GRAY LOW ANGLE NOZZLE PERFORMANCE DATA

Nozzle	Pressure (PSI)	Radius (FT.)	Flow (GPM)	Precip in/hr	
				■	▲
2.0 LA Gray	30	25	1.6	0.49	0.57
	40	27	1.9	0.50	0.58
	50	28	2.1	0.52	0.60
	60	30	2.3	0.49	0.57
	30	27	2.1	0.55	0.64
2.5 LA Gray	40	30	2.5	0.53	0.62
	50	33	2.8	0.49	0.57
	60	35	3.0	0.47	0.54
	30	29	2.8	0.64	0.74
	40	32	3.1	0.58	0.67
3.5 LA Gray	50	35	3.5	0.55	0.64
	60	37	3.8	0.53	0.62
	30	29	3.4	0.78	0.90
	40	32	3.9	0.73	0.85
	50	35	4.4	0.69	0.80
4.0 LA Gray	60	37	4.7	0.66	0.76
	35	36	2.7	0.40	0.46
	45	38	3.0	0.40	0.46
	55	39	3.4	0.43	0.50
	65	39	3.7	0.47	0.54

PGP ULTRA BLACK SHORT RADIUS NOZZLE PERFORMANCE DATA (18'/25')

Nozzle	Pressure (PSI)	Radius (FT.)	Flow (GPM)	Precip in/hr	
				■	▲
.50 SR Black	30	17	0.36	0.24	0.28
	40	17	0.43	0.29	0.33
	50	18	0.50	0.30	0.34
	60	19	0.57	0.30	0.35
1.0 SR Black	30	17	0.78	0.52	0.60
	40	17	0.90	0.60	0.69
	50	18	1.00	0.59	0.69
	60	19	1.10	0.59	0.68
2.0 SR Black	30	17	1.40	0.93	1.08
	40	17	1.70	1.13	1.31
	50	18	2.00	1.19	1.37
	60	19	2.20	1.17	1.35
.75 SR Black	30	23	0.58	0.21	0.24
	40	24	0.68	0.23	0.26
	50	25	0.75	0.23	0.27
	60	26	0.83	0.24	0.27
1.5 SR Black	30	23	1.10	0.40	0.46
	40	24	1.30	0.43	0.50
	50	25	1.50	0.46	0.53
	60	26	1.60	0.46	0.53
3.0 SR Black	30	23	2.50	0.91	1.05
	40	24	2.70	0.90	1.04
	50	25	3.00	0.92	1.07
	60	26	3.10	0.88	1.02

Bold = Recommended pressure

Note:

All precipitation rates calculated for 180 degree operation. For the precipitation rate for a 360 degree sprinkler, divide by 2.

PGP ULTRA NOZZLES



Blue Standard / Gray Low Angle (P/N 782900)



Dk. Green High Flow (P/N 444800)

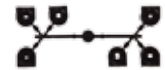

Black Short Radius (P/N 466100)



ROTORS

I-20

Application: **Residential/Commercial**
 Radius: **17' to 46'**
 Flow Rate: **0.36 to 14.8 GPM**
 Inlet Size: **¾" NPT**

FEATURES

- Models plastic riser: Shrub, 4", 6", 12"
- Models stainless riser: 4", 6"
- Arc setting: 50 to 360 degrees
- Factory installed rubber cover
- Through-the-top arc adjustment
- Quick check arc mechanism
- Water lubricated gear-drive
- Nozzle choices: 22
- Nozzle racks: 1.5 to 8.0 blue, 2.0 LA to 4.5 LA grey, 0.50 to 3.0 black, 6.0 to 13.0 green
- Warranty period: 5 years
- ▶ Automatic arc return
- ▶ Non-strippable drive
- ▶ Part- and full-circle in one model
- ▶ Headed and slotted set screw
- ▶ FloStop® control
- ▶ Reclaimed water ID
- ▶ Stainless steel riser
- ▶ Drain check valve (Up to 10 ft. of elevation)

OPERATING SPECIFICATIONS

- Radius: 17' to 46'
- Flow Rate: 0.36 to 14.8 GPM
- Recommended pressure range: 25 to 70 PSI
- Operating pressure range: 20 to 100 PSI
- Precipitation rates: 0.4 in/hr approx.
- Nozzle trajectory: Std = 25 degrees, Low angle = 13 degrees

▶ = Advanced Feature descriptions on page 12

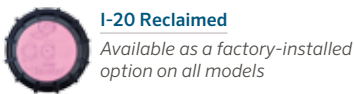

I-20-00
 Overall height: 7¾"
 Exposed diameter: 1¾"
 Inlet size: ¾" female NPT



I-20-04
 Overall height: 7½"
 Pop-up height: 4"
 Exposed diameter: 1¾"
 Inlet size: ¾" female NPT



I-20-06
 Overall height: 9¾"
 Pop-up height: 6"
 Exposed diameter: 1¾"
 Inlet size: ¾" female NPT



I-20-12
 Overall height: 17"
 Pop-up height: 12"
 Exposed diameter: 1¾"
 Inlet size: ¾" female NPT

I-20 (PLASTIC) - SPECIFICATION BUILDER: ORDER 1 + 2 + 3 + 4

1 Models	2 Standard Features	3 Feature Options	4 Nozzle Options
I-20-00 = Shrub I-20-04 = 4" Pop-up I-20-06 = 6" Pop-up I-20-12 = 12" Pop-up	Adjustable arc, plastic riser, check valve, 8 standard nozzles, and 4 low-angle nozzles	(blank) = No option NCV = Without check valve (only available on 4" model) R = Drain check valve and reclaimed water ID	1.5 to 4.0 = Factory installed nozzle number

I-20 (STAINLESS STEEL) - SPECIFICATION BUILDER: ORDER 1 + 2 + 3 + 4

1 Models	2 Standard Features	3 Feature Options	4 Nozzle Options
I-20-04-SS = 4" Pop-up I-20-06-SS = 6" Pop-up	Adjustable arc, stainless steel riser, check valve, 8 standard nozzles, and 4 low-angle nozzles	(blank) = No option NCV = Without check valve (only available on 4" model) R = Drain check valve and reclaimed water ID	1.5 to 4.0 = Factory installed nozzle number

Examples:
 I-20-04 = 4" pop-up, adjustable arc
 I-20-12 - R - 4.0 = 12" pop-up, adjustable arc, with reclaimed water ID, and 4.0 nozzle
 I-20-06-SS - R - 3.0 = 6" pop-up, adjustable arc, stainless steel, reclaimed water ID, and 3.0 nozzle

I-20 BLUE STANDARD NOZZLE PERFORMANCE DATA

Nozzle	Pressure (PSI)	Radius (FT.)	Flow (GPM)	Precip in/hr	
				■	▲
1.5 ● Blue	25	29	1.2	0.27	0.32
	35	31	1.4	0.28	0.32
	45	31	1.5	0.30	0.35
	55	32	1.8	0.34	0.39
	65	32	1.9	0.36	0.41
2.0 ● Blue	25	33	1.4	0.25	0.29
	35	33	1.7	0.30	0.35
	45	34	2.0	0.33	0.38
	55	34	2.1	0.35	0.40
	65	32	2.3	0.43	0.50
2.5 ● Blue	25	33	1.7	0.30	0.35
	35	35	2.1	0.33	0.38
	45	35	2.5	0.39	0.45
	55	35	2.6	0.41	0.47
	65	35	2.9	0.46	0.53
3.0 ● Blue	25	35	2.2	0.35	0.40
	35	36	2.7	0.40	0.46
	45	38	3.0	0.40	0.46
	55	39	3.4	0.43	0.50
	65	39	3.7	0.47	0.54
4.0 ● Blue	25	37	3.0	0.42	0.49
	35	39	3.5	0.44	0.51
	45	40	4.0	0.48	0.56
	55	41	4.5	0.52	0.60
	65	41	4.8	0.55	0.63
5.0 ● Blue	25	37	3.7	0.52	0.60
	35	39	4.5	0.57	0.66
	45	42	5.0	0.55	0.63
	55	42	5.7	0.62	0.72
	65	42	6.2	0.68	0.78
6.0 ● Blue	25	38	4.3	0.57	0.66
	35	40	5.6	0.67	0.78
	45	43	6.0	0.62	0.72
	55	44	6.7	0.67	0.77
	65	44	7.3	0.73	0.84
8.0 ● Blue	25	37	6.0	0.84	0.97
	35	41	7.0	0.80	0.93
	45	44	8.0	0.80	0.92
	55	46	9.0	0.82	0.95
	65	46	9.8	0.89	1.03

I-20 HIGH FLOW NOZZLE PERFORMANCE DATA

Nozzle	Pressure (PSI)	Radius (FT.)	Flow (GPM)	Precip in/hr	
				■	▲
10 ● Dk. Green	40	42	8.4	0.92	1.06
	50	43	9.5	0.99	1.14
	60	45	10.5	1.00	1.15
	70	47	11.4	0.99	1.15
13 ● Dk. Green	40	43	10.9	1.13	1.31
	50	44	12.3	1.22	1.41
	60	45	13.6	1.29	1.49
	70	47	14.8	1.29	1.49
6.0 ● LA Dk. Green	30	31	4.2	0.84	0.97
	40	35	5.0	0.79	0.91
	50	37	5.8	0.82	0.94
	60	39	6.3	0.80	0.92
8.0 ● LA Dk. Green	40	37	6.7	0.94	1.09
	50	39	7.7	0.97	1.13
	60	41	8.5	0.97	1.12
	70	41	9.2	1.05	1.22

I-20 LOW ANGLE NOZZLE PERFORMANCE DATA

Nozzle	Pressure (PSI)	Radius (FT.)	Flow (GPM)	Precip in/hr	
				■	▲
2.0 ● LA Gray	30	25	1.6	0.49	0.57
	40	27	1.9	0.5	0.58
	50	28	2.1	0.52	0.6
	60	30	2.3	0.49	0.57
	30	27	2.1	0.55	0.64
2.5 ● LA Gray	40	30	2.5	0.53	0.62
	50	33	2.8	0.49	0.57
	60	35	3	0.47	0.54
	30	29	2.8	0.64	0.74
	40	32	3.1	0.58	0.67
3.5 ● LA Gray	50	35	3.5	0.55	0.64
	60	37	3.8	0.53	0.62
	30	29	3.4	0.78	0.9
	40	32	3.9	0.73	0.85
	50	35	4.4	0.69	0.8
4.0 ● LA Gray	60	37	4.7	0.66	0.76
	35	36	2.7	0.40	0.46
	45	38	3.0	0.40	0.46
	55	39	3.4	0.43	0.50
	65	39	3.7	0.47	0.54

I-20 BLACK SHORT RADIUS NOZZLE PERFORMANCE DATA (18'/25')

Nozzle	Pressure (PSI)	Radius (FT.)	Flow (GPM)	Precip in/hr	
				■	▲
.50 ● SR Black	30	17	0.36	0.24	0.28
	40	17	0.43	0.29	0.33
	50	18	0.50	0.30	0.34
	60	19	0.57	0.30	0.35
1.0 ● SR Black	30	17	0.78	0.52	0.60
	40	17	0.90	0.60	0.69
	50	18	1.00	0.59	0.69
	60	19	1.10	0.59	0.68
2.0 ● SR Black	30	17	1.40	0.93	1.08
	40	17	1.70	1.13	1.31
	50	18	2.00	1.19	1.37
	60	19	2.20	1.17	1.35
.75 ● SR Black	30	23	0.58	0.21	0.24
	40	24	0.68	0.23	0.26
	50	25	0.75	0.23	0.27
	60	26	0.83	0.24	0.27
1.5 ● SR Black	30	23	1.10	0.40	0.46
	40	24	1.30	0.43	0.50
	50	25	1.50	0.46	0.53
	60	26	1.60	0.46	0.53
3.0 ● SR Black	30	23	2.50	0.91	1.05
	40	24	2.70	0.90	1.04
	50	25	3.00	0.92	1.07
	60	26	3.10	0.88	1.02

Bold = Recommended pressure

Note:

All precipitation rates calculated for 180 degree operation. For the precipitation rate for a 360 degree sprinkler, divide by 2.

I-20 NOZZLES

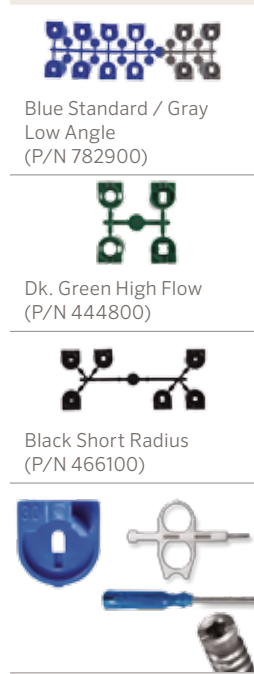

Blue Standard / Gray Low Angle (P/N 782900)

Dk. Green High Flow (P/N 444800)

Black Short Radius (P/N 466100)

ROTORS

I-25

Application: **Commercial/Municipal**

Radius: **40' to 71'**

Flow Rate: **3.8 to 31.5 GPM**

Inlet Size: **1" NPT**

FEATURES

- Models plastic riser: 4", 6"
- Models stainless riser: 4", 6"
- Arc setting: 50 to 360 degrees
- Factory installed rubber cover
- Through-the-top arc adjustment
- Quick check arc mechanism
- Water lubricated gear-drive
- Nozzle choices: 12
- Nozzle range: #4 to #28
- Warranty period: 5 years
- ▶ Automatic arc return
- ▶ Non-strippable drive
- ▶ Part- and full-circle in one model
- ▶ Color coded nozzles
- ▶ Reclaimed water ID
- ▶ Stainless steel riser
- ▶ Drain check valve (Up to 10 ft. of elevation)



I-25-04

Overall height: 7 7/8"
Pop-up height: 4"
Exposed diameter: 1 1/4"
Inlet size: 1" female NPT



I-25-06

Overall height: 10 1/4"
Pop-up height: 6"
Exposed diameter: 1 1/4"
Inlet size: 1" female NPT

OPERATING SPECIFICATIONS

- Radius: 37' to 71'
- Flow rate: 3.8 to 31.5 GPM
- Recommended pressure range: 40 to 100 PSI
- Operating pressure range: 40 to 100 PSI
- Precipitation rates: 0.4 in/hr approx.
- Nozzle trajectory: 25 degrees

▶ = Advanced Feature descriptions on page 12



I-25 Reclaimed

Available as a factory-installed option on all models

I-25 (PLASTIC) - SPECIFICATION BUILDER: ORDER 1 + 2 + 3 + 4

1 Models	2 Standard Features	3 Feature Options	4 Nozzle Options
I-25-04 = 4" Pop-up I-25-06 = 6" Pop-up	Adjustable arc, plastic riser, check valve, and 5 nozzles	(blank) = No option R = Reclaimed water ID B = BSP inlet threads	#4 to #28 = Factory installed nozzle number

I-25 (STAINLESS STEEL) - SPECIFICATION BUILDER: ORDER 1 + 2 + 3 + 4

1 Models	2 Standard Features	3 Feature Options	4 Nozzle Options
I-25-04-SS = 4" Pop-up I-25-06-SS = 6" Pop-up	Adjustable arc, stainless steel riser, check valve, and 5 nozzles	(blank) = No option R = Reclaimed water ID HS = High speed HS-R = High speed and reclaimed water ID B = BSP inlet threads	#4 to #28 = Factory installed nozzle number

Examples:

I-25-04 = 4" pop-up, adjustable arc

I-25-04-SS - R - 18 = 4" pop-up, adjustable arc, stainless steel riser, reclaimed water ID, and #18 nozzle

I-25-06-SS = 6" pop-up, adjustable arc, stainless steel riser

I-25 NOZZLE PERFORMANCE DATA					
Nozzle	Pressure (PSI)	Radius (FT.)	Flow (GPM)	Precip in/hr	
				■	▲
04 ● Yellow	40	40	3.8	0.46	0.53
	50	41	4.3	0.49	0.57
	60	42	4.7	0.51	0.59
	70	43	5.1	0.53	0.61
05 ○ White	40	43	4.4	0.46	0.53
	50	44	4.8	0.48	0.55
	60	45	5.3	0.50	0.58
	70	46	5.6	0.51	0.59
07 ● Orange*	40	45	6.6	0.63	0.72
	50	47	7.0	0.61	0.70
	60	48	7.5	0.63	0.72
	70	49	7.9	0.63	0.73
08 ● Lt. Brown	40	47	7.7	0.67	0.77
	50	49	8.3	0.67	0.77
	60	50	9.2	0.71	0.82
	70	51	9.9	0.73	0.85
10 ● Lt. Green*	50	51	10.1	0.75	0.86
	60	52	11.1	0.79	0.91
	70	53	12.1	0.83	0.96
	80	54	12.9	0.85	0.98
13 ● Lt. Blue	50	53	11.2	0.77	0.89
	60	54	12.3	0.81	0.94
	70	55	13.3	0.85	0.98
	80	55	14.3	0.91	1.05
15 ● Gray*	50	56	13.4	0.82	0.95
	60	57	14.3	0.85	0.98
	70	57	15.2	0.9	1.04
	80	58	16.4	0.94	1.08
18 ● Red	50	58	14.5	0.83	0.96
	60	59	15.7	0.87	1.00
	70	62	16.9	0.85	0.98
	80	63	18.2	0.88	1.02
20 ● Dk. Brown*	60	62	17.8	0.89	1.03
	70	63	19.2	0.93	1.08
	80	64	20.5	0.96	1.11
	90	65	21.8	0.99	1.15
23 ● Dk. Green	60	64	21.9	1.03	1.19
	70	65	23.6	1.08	1.24
	80	66	25.6	1.13	1.31
	90	67	27.0	1.16	1.34
25 ● Dk. Blue*	60	66	23.5	1.04	1.20
	70	68	25.5	1.06	1.23
	80	69	28.0	1.13	1.31
	90	70	29.5	1.16	1.34
28 ● Black	70	68	26.9	1.12	1.29
	80	70	28.7	1.13	1.30
	90	71	30.6	1.17	1.35
	100	71	31.5	1.20	1.39

I-25 HIGH-SPEED NOZZLE PERFORMANCE DATA					
Nozzle	Pressure (PSI)	Radius (FT.)	Flow (GPM)	Precip in/hr	
				■	▲
04 ● Yellow	40	37	3.8	0.53	0.62
	50	38	4.3	0.57	0.66
	60	38	4.7	0.63	0.72
	70	39	5.2	0.66	0.76
05 ○ White	40	38	4.4	0.59	0.68
	50	39	4.8	0.61	0.70
	60	40	5.5	0.66	0.76
	70	41	6	0.69	0.79
07 ● Orange*	40	40	6.1	0.73	0.85
	50	41	6.9	0.79	0.91
	60	42	7.5	0.82	0.95
	70	44	8.1	0.81	0.93
08 ● Lt. Brown	40	42	7.2	0.79	0.91
	50	43	8.1	0.84	0.97
	60	44	8.9	0.88	1.02
	70	45	9.8	0.93	1.08
10 ● Lt. Green*	50	46	10.1	0.92	1.06
	60	48	11.1	0.93	1.07
	70	49	12.1	0.97	1.12
	80	50	12.9	0.99	1.15
13 ● Lt. Blue	50	48	11.2	0.94	1.08
	60	49	12.3	0.99	1.14
	70	51	13.3	0.98	1.14
	80	51	14.3	1.06	1.22
15 ● Gray*	50	49	13.4	1.07	1.24
	60	51	14.3	1.06	1.22
	70	53	15.2	1.04	1.20
	80	54	16.4	1.08	1.25
18 ● Red	50	50	14.5	1.12	1.29
	60	53	15.7	1.08	1.24
	70	55	16.9	1.08	1.24
	80	57	18.2	1.08	1.25
20 ● Dk. Brown*	60	53	17.8	1.22	1.41
	70	56	19.2	1.18	1.36
	80	58	20.5	1.17	1.35
	90	59	21.8	1.21	1.39
23 ● Dk. Green	60	56	21.9	1.34	1.55
	70	58	23.6	1.35	1.56
	80	60	25.6	1.37	1.58
	90	61	27	1.40	1.61
25 ● Dk. Blue*	60	58	23.5	1.34	1.55
	70	62	25.5	1.28	1.47
	80	64	28	1.32	1.52
	90	66	29.5	1.30	1.51
28 ● Black	70	60	26.9	1.44	1.66
	80	62	28.7	1.44	1.66
	90	65	30.6	1.39	1.61
	100	67	31.5	1.35	1.56

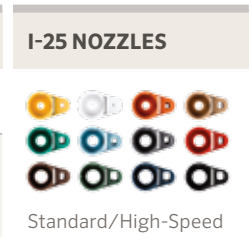

* 5 standard nozzles included with each sprinkler.

* 5 standard nozzles included with each sprinkler.

Notes:

All precipitation rates calculated for 180 degree operation. For the precipitation rate for 360 degree sprinkler, divide by 2.

I-40

Application: **Commercial/Municipal**
 Radius: **44' to 69'**
 Flow Rate: **7.6 to 29.5 GPM**
 Inlet Size: **1" NPT**

FEATURES

- Models stainless riser: 4", 6"
 - Arc setting: 50 to 360 degrees
 - Factory installed rubber cover
 - Nozzle choices: 12
 - Nozzle ranges I-40: #8 to #25
 - Nozzle ranges I-40-ON: #15 to #28
 - Through-the-top arc adjustment
 - Quick check arc mechanism
 - Water lubricated gear-drive
 - Warranty period: 5 years
- ▶ Opposing nozzle 360° model
 - ▶ Automatic arc return
 - ▶ Non-strippable drive
 - ▶ Part- and full-circle in one model
 - ▶ Color coded nozzles
 - ▶ Reclaimed water ID
 - ▶ Stainless steel riser
 - ▶ Drain check valve (Up to 15 ft. of elevation)



I-40-04
 Overall height: 7 7/8"
 Pop-up height: 4"
 Exposed diameter: 2"
 Inlet size: 1" female NPT



I-40-06
 Overall height: 10 1/4"
 Pop-up height: 6"
 Exposed diameter: 2"
 Inlet size: 1" female NPT

OPERATING SPECIFICATIONS

- Radius I-40: 44' to 69'
- Radius I-40-ON: 52' to 76'
- Flow rate I-40: 7.6 to 29.5 GPM
- Flow rate I-40-ON: 13.0 to 33.7 GPM
- Recommended pressure range: 40 to 100 PSI
- Operating pressure range: 40 to 100 PSI
- Precipitation rates: 0.4 in/hr approx.
- Nozzle trajectory: 25 degrees

▶ = Advanced Feature descriptions on page 12



I-40 Reclaimed

Available as a factory-installed option on all models

I-40 - SPECIFICATION BUILDER: ORDER 1 + 2 + 3 + 4

1 Models	2 Standard Features	3 Feature Options	4 Nozzle Options
I-40-04-SS = 4" Pop-up I-40-06-SS = 6" Pop-up	Adjustable arc, stainless steel riser, check valve, and 6 nozzles	(blank) = No option HS = High speed HS-R = High speed and reclaimed water ID B = BSP inlet threads R = Reclaimed water ID	#8 to #25 = Factory installed nozzle number

I-40-ON - SPECIFICATION BUILDER: ORDER 1 + 2 + 3 + 4

1 Opposing Nozzle Models	2 Standard Features	3 Feature Options	4 Nozzle Options
I-40-04-SS-ON = 4" Pop-up I-40-06-SS-ON = 6" Pop-up	Full-circle, opposing nozzle, stainless steel riser, check valve and 6 nozzles	(blank) = No option ON = Full circle opposing nozzles ON-R = Full circle opposing nozzles and reclaimed water ID HS = High speed HS-R = High speed and reclaimed water ID B = BSP inlet threads R = Reclaimed water ID	#15 to #28 = Factory installed nozzle number

Examples:

- I-40-04-SS = 4" pop-up, adjustable arc
- I-40-04-SS - **ON-R** - 23 = 4" pop-up, adjustable arc, full circle opposing nozzles, reclaimed water ID, and #23 nozzle
- I-40-06-SS - 15 = 6" pop-up, adjustable arc, and #15 nozzle

I-40 NOZZLE PERFORMANCE DATA					
Nozzle	Pressure (PSI)	Radius (FT.)	Flow (GPM)	Precip in/hr	
				■	▲
8 (40) Lt. Brown	40	44	7.6	0.76	0.87
	50	45	8.4	0.80	0.92
	60	46	9.2	0.84	0.97
10 (41) Lt. Green	50	49	10.3	0.83	0.95
	60	50	11.3	0.87	1.00
	70	51	12.2	0.90	1.04
13 (42) Lt. Blue	50	50	11.1	0.85	0.99
	60	51	12.3	0.91	1.05
	70	52	13.3	0.95	1.08
15 (43) Gray	50	54	13.8	0.91	1.05
	60	55	15.7	1.00	1.15
	70	57	16.6	0.98	1.14
23 (44) Dk. Green	80	59	18.3	1.01	1.17
	60	62	21.3	1.07	1.23
	70	64	23.0	1.08	1.25
25 (45) Dk. Blue	80	65	24.5	1.12	1.29
	90	66	25.9	1.14	1.32
	60	66	23.9	1.06	1.22
25 (45) Dk. Blue	70	67	25.8	1.11	1.28
	80	68	27.7	1.15	1.33
	90	69	29.5	1.19	1.38

I-40 HIGH-SPEED NOZZLE PERFORMANCE DATA					
Nozzle	Pressure (PSI)	Radius (FT.)	Flow (GPM)	Precip in/hr	
				■	▲
8 (40) Lt. Brown	40	41	7.6	0.87	1.00
	50	41	8.4	0.96	1.11
	60	42	9.2	1.00	1.16
10 (41) Lt. Green	50	45	10.3	0.98	1.13
	60	46	11.3	1.03	1.19
	70	47	12.2	1.06	1.23
13 (42) Lt. Blue	80	47	13.0	1.13	1.31
	50	46	11.1	1.01	1.17
	60	47	12.3	1.07	1.24
15 (43) Gray	70	48	13.3	1.11	1.28
	80	49	14.2	1.14	1.31
	50	51	13.8	1.02	1.18
23 (44) Dk. Green	60	52	15.7	1.12	1.29
	70	53	16.6	1.14	1.31
	80	54	18.3	1.21	1.40
25 (45) Dk. Blue	90	58	21.3	1.22	1.41
	60	58	21.3	1.22	1.41
	70	59	23.0	1.27	1.47
25 (45) Dk. Blue	80	60	24.5	1.31	1.51
	90	61	25.9	1.34	1.55
	60	59	23.9	1.32	1.53
25 (45) Dk. Blue	70	61	25.8	1.33	1.54
	80	62	27.7	1.39	1.60
	90	63	29.5	1.43	1.65

I-40 NOZZLES

Standard/High-Speed

Opposing Nozzle 360° Model

I-40 DUAL OPPOSING NOZZLE PERFORMANCE DATA					
Nozzle	Pressure (PSI)	Radius (FT.)	Flow (GPM)	Precip in/hr	
				■	▲
15 (43) Gray	50	52	13.0	0.46	0.53
	60	54	13.2	0.44	0.50
	70	56	14.4	0.44	0.51
	80	57	15.5	0.46	0.53
18 (44) Red	50	58	13.7	0.39	0.45
	60	59	15.2	0.42	0.49
	70	60	16.6	0.44	0.51
20 (45) Dk. Brown	80	62	17.8	0.45	0.51
	60	63	19.1	0.46	0.53
	70	64	20.9	0.49	0.57
23 (46) Dk. Green	80	66	22.3	0.49	0.57
	90	66	23.9	0.53	0.61
	60	65	20.4	0.46	0.54
25 (47) Dk. Blue*	70	66	22.3	0.49	0.57
	80	67	24.0	0.51	0.59
	90	68	25.6	0.53	0.62
28 (48) Black	60	66	22.0	0.49	0.56
	70	68	24.0	0.50	0.58
	80	69	25.9	0.52	0.60
28 (48) Black	90	70	27.2	0.53	0.62
	70	70	28.9	0.57	0.66
	80	72	30.9	0.57	0.66
28 (48) Black	90	74	32.9	0.58	0.67
	100	76	33.7	0.56	0.65

I-40 NOZZLES

Opposing

* Factory-installed nozzle

Notes:

All precipitation rates calculated for 180-degree operation. For the precipitation rate for a 360-degree sprinkler, divide by 2. Precipitation rates for the ON-Opposing Nozzle model are calculated at 360 degrees.

I-60

Application: **Commercial**
 Radius: **50' to 67'**
 Flow Rate: **6.5 to 20.8 GPM**
 Inlet Size: **1" NPT**

FEATURES

- Model stainless riser: 4"
- Exclusive *Precision Distribution Control*™ nozzle mechanism
- Standard factory installed nozzle: #13
- I-60-ADS arc setting: 40–360 degrees
- I-60-36S arc setting: full-circle only
- Nozzle choices: 6
- Nozzle range: #7 to #20
- Factory installed rubber cover
- Through-the-top arc adjustment
- Quick check arc mechanism
- Water lubricated gear-drive
- Warranty period: 5 years
- ▶ Color coded nozzles
- ▶ Optional reclaimed water ID
- ▶ Stainless steel riser
- ▶ Drain check valve (up to 10 ft. of elevation)



I-60
 Overall height: ADS/36S: 8¾"
 Pop-up height: 3"
 Exposed diameter: 1¾"
 Inlet size: 1" female NPT

OPERATING SPECIFICATIONS

- Radius: 50' to 67'
- Flow rate: 6.5 to 20.8 GPM
- Recommended pressure range: 40 to 60 PSI
- Operating pressure range: 20 to 100 PSI
- Precipitation rates: 0.4 in/hr approx.
- Nozzle trajectory: 25 degrees

▶ = *Advanced Feature descriptions on page 12*







I-60 – SPECIFICATION BUILDER: ORDER 1 + 2 + 3

1 Models	2 Standard Features	3 Feature Options
I-60 = 4" Pop-up	Stainless steel riser, check valve, and 6 nozzles	(blank) = No option ADS = Adjustable arc 36S = Full circle B = BSP inlet threads #13 = Factory installed nozzle number

Examples:

I-60 - ADS = 4" pop-up, adjustable arc







I-60 - 36S - 10 = 43" pop-up, full circle, and #10 nozzle

I-60 ADS NOZZLE PERFORMANCE DATA					
Nozzle	Pressure (PSI)	Radius (FT.)	Flow (GPM)	Precip in/hr	
				■	▲
7  Orange	40	50	6.5	0.50	0.58
	50	52	7.1	0.51	0.58
	60	54	7.7	0.51	0.59
10  Lt. Green	40	53	8.5	0.58	0.67
	50	56	9.5	0.58	0.67
	60	58	10.2	0.58	0.67
13  Lt. Blue*	40	56	10.5	0.64	0.74
	50	58	12.1	0.69	0.80
	60	60	13.0	0.70	0.80
15  Gray	40	58	12.5	0.72	0.83
	50	60	13.9	0.74	0.86
	60	62	15.1	0.76	0.87
18  Red	40	59	15.6	0.86	1.00
	50	62	17.5	0.88	1.01
	60	65	18.6	0.85	0.98
20  Dk. Brown	40	62	17.5	0.88	1.01
	50	64	19.1	0.90	1.04
	60	66	20.4	0.90	1.04

* Factory-installed nozzle

Notes:

Precipitation rates for ADS models are calculated for 180-degree operation. To calculate precipitation rate for 360-degree operation, divide by 2.

I-60 36S NOZZLE PERFORMANCE DATA					
Nozzle	Pressure (PSI)	Radius (FT.)	Flow (GPM)	Precip in/hr	
				■	▲
7  Orange	40	51	6.5	0.24	0.28
	50	54	7.5	0.25	0.29
	60	56	8.0	0.25	0.28
10  Lt. Green	40	53	8.5	0.29	0.34
	50	56	9.5	0.29	0.34
	60	58	10.2	0.29	0.34
13  Lt. Blue*	40	56	10.5	0.32	0.37
	50	58	12.4	0.35	0.41
	60	60	13.0	0.35	0.40
15  Gray	40	58	12.5	0.36	0.41
	50	60	14.0	0.37	0.43
	60	62	15.1	0.38	0.44
18  Red	40	59	15.6	0.43	0.50
	50	62	17.7	0.44	0.51
	60	65	18.9	0.43	0.50
20  Dk. Brown	40	62	17.5	0.44	0.51
	50	64	19.1	0.45	0.52
	60	67	20.8	0.45	0.51

* Factory-installed nozzle

Notes:

Precipitation rates for 36S model are calculated at 360 degrees.

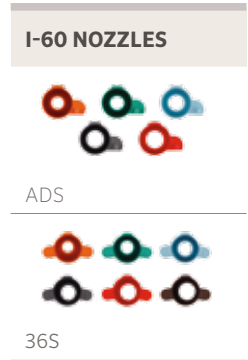

I-90

Application: **Large Radius Commercial/Municipal**
 Radius: **63' to 101'**
 Flow Rate: **22 to 83 GPM**
 Inlet Size: **1½" NPT**

FEATURES

- Model: 3"
- Arc setting: 40 to 360 degrees
- Nozzle choices: 8
- Nozzle range: #25 to #73
- Through-the-top arc adjustment
- Quick check arc mechanism
- Water lubricated gear-drive
- Standard factory installed nozzle: #53
- Factory installed rubber logo cap
- Warranty period: 5 years
- ▶ Opposing nozzle 360° model
- ▶ Color coded nozzles
- ▶ Optional reclaimed water ID
- ▶ Drain check valve (up to 9 ft. of elevation)

OPERATING SPECIFICATIONS

- Radius: 63' to 101'
- Flow rate: 22 to 83 GPM
- Recommended pressure range: 60 to 110 PSI
- Operating pressure range: 50 to 120 PSI
- Precipitation rates: 0.75 in/hr approx.
- Nozzle trajectory: 22.5 degrees

USER-INSTALLED OPTION

- Turf Cup Kit
 - I-90 all: P/N 467955
- Rubber Cover Kit
 - I-90-ADV: P/N 234200 (all)
 - I-90-36V: P/N 234200 (0711 date code and after)
 - I-90-36V: P/N 234201 (0611 date code & prior only)

▶ = Advanced Feature descriptions on page 12



I-90 Reclaimed
 Available as a factory-installed option on all models



I-90
 Overall height: ADV/36V: 11"
 Pop-up height: 3"
 Exposed diameter: 3½"
 Inlet size: 1½" female NPT



Turf cup kit
 P/N 467955



Rubber cover kits
 P/N 234200; P/N 234201

I-90 - SPECIFICATION BUILDER: ORDER 1 + 2 + 3 + 4

1 Models	2 Standard Features	3 Feature Options	4 Nozzle Options
I-90 = 3" Pop-up	Plastic riser, check valve, and 8 nozzles	ADV = Adjustable arc ARV = Adjustable arc and reclaimed water ID 36V = Full circle, opposing nozzles 3RV = Full circle, opposing nozzles and reclaimed water ID	#25 to #73 = Factory installed nozzle number

Examples:
 I-90 - **ADV** = 3" pop-up, adjustable arc
 I-90 - **36V** - **43** = 3" pop-up, full circle, opposing nozzles, and #43 nozzle
 I-90 - **3RV** - **63** = 3" pop-up, full circle, opposing nozzles, reclaimed water ID, and #63 nozzle

I-90-ADV NOZZLE PERFORMANCE DATA					
Nozzle	Pressure (PSI)	Radius (FT.)	Flow (GPM)	Precip in/hr	
				■	▲
25 ● Lt. Blue	60	63	22.0	1.07	1.23
	70	64	24.9	1.17	1.35
	80	65	27.5	1.25	1.45
	90	67	28.8	1.24	1.43
	100	68	30.6	1.27	1.47
33 ● Gray	60	67	30.7	1.32	1.52
	70	67	33.1	1.42	1.64
	80	68	35.5	1.48	1.71
	90	69	37.7	1.52	1.76
	100	70	39.8	1.56	1.81
38 ● Red	60	69	34.0	1.37	1.59
	70	70	36.9	1.45	1.67
	80	72	39.8	1.48	1.71
	90	73	42.3	1.53	1.76
	100	75	44.1	1.51	1.74
43 ● Dk. Brown	60	70	38.7	1.52	1.76
	70	71	42.0	1.60	1.85
	80	72	44.5	1.65	1.91
	90	73	47.6	1.72	1.99
	100	73	48.3	1.74	2.01
48 ● Dk. Green	70	75	47.0	1.61	1.86
	80	77	50.2	1.63	1.88
	90	79	53.3	1.64	1.90
	100	81	56	1.64	1.90
	53 ● Dk. Blue*	70	79	48.5	1.50
80		81	53.4	1.57	1.81
90		85	57.0	1.52	1.75
100		86	59.5	1.55	1.79
63 ● Black		70	84	60.9	1.66
	80	86	63.8	1.66	1.92
	90	88	66.5	1.65	1.91
	100	90	69.8	1.66	1.92
	73 ● Orange	80	90	66.9	1.59
90		92	69.7	1.59	1.83
100		95	72.8	1.55	1.79
110		98	76.2	1.53	1.76

* Factory-installed nozzle

Notes:

Precipitation rates for ADV models are calculated for 180-degree operation. To calculate precipitation rate for 360-degree operation, divide by 2. Precipitation rates for 36V model are calculated at 360 degrees.

I-90-36V NOZZLE PERFORMANCE DATA					
Nozzle	Pressure (PSI)	Radius (FT.)	Flow (GPM)	Precip in/hr	
				■	▲
25 ● Lt. Blue	60	69	25.5	0.52	0.6
	70	71	27.8	0.53	0.61
	80	73	30.2	0.55	0.63
	90	75	31.7	0.54	0.63
	100	77	33.9	0.55	0.64
33 ● Gray	60	71	29.8	0.57	0.66
	70	74	32.2	0.57	0.65
	80	76	34.4	0.57	0.66
	90	78	36.8	0.58	0.67
	100	80	38.6	0.58	0.67
38 ● Red	60	74	33.3	0.59	0.68
	70	77	36.1	0.59	0.68
	80	79	38.4	0.59	0.68
	90	80	40.9	0.62	0.71
	100	82	42.8	0.61	0.71
43 ● Dk. Brown	60	77	38.1	0.62	0.71
	70	79	40.9	0.63	0.73
	80	82	43.9	0.63	0.73
	90	83	46.5	0.65	0.75
	100	84	48.5	0.66	0.76
48 ● Dk. Green	70	82	46.3	0.66	0.77
	80	86	49.6	0.65	0.75
	90	89	52.5	0.64	0.74
	100	90	54.8	0.65	0.75
	53 ● Dk. Blue*	70	85	50.5	0.67
80		88	53.5	0.66	0.77
90		90	57.4	0.68	0.79
100		92	59.5	0.68	0.78
63 ● Black		70	90	60.6	0.72
	80	92	63.2	0.72	0.83
	90	94	65.9	0.72	0.83
	100	96	69.4	0.72	0.84
	73 ● Orange	80	95	72.1	0.77
90		97	75.9	0.78	0.90
100		99	79.5	0.78	0.90
110		101	83.0	0.78	0.90

I-90 NOZZLES

ADV & 36V

Low-Angle ADV & 36V**

** Low angle nozzles reduce radius by 15%

ST SYSTEM ROTORS

Application: **Synthetic Turf Sports Fields**

Radius: **103' to 165'**

Flow Rate: **74.5 to 326.8 GPM**

Inlet Size: **1½" NPT, 1½" ACME & 2" BSP**

FEATURES

- Models
 - ST-90: 3" jar top
 - STG-900: 3" top service
 - ST-1600B: 5" top service
 - ST-1600BR: Riser mount
- Nozzle choices
 - ST-90, STG-900: 2
 - ST-1600B, ST-1600BR: 6
- Nozzle ranges
 - ST-90, STG-900: #73 to 83
 - ST-1600B, ST-1600BR: #16 to 26
- Standard installed nozzle
 - ST-90, STG-900: #73
 - ST-1600B, ST-1600BR: #20
- Arc adjustment
 - ST-90, STG-900: Through-the-top
 - ST-1600B, ST-1600BR: Movable stops
- Arc setting: 40 to 360 degrees (all models)
- Quick check arc mechanism (all models)
- Gear-drive
 - ST-90, STG-900: Water lubricated
 - ST-1600B, ST-1600BR: Isolated grease lubrication
- Ratcheting nozzle turret: ST-1600B, ST-1600BR
- Telescoping infill protection barrier: ST-1600B
- Factory installed rubber logo cap (all pop-up models)
- Nozzle trajectory: 22.5 degrees (all models)
- 5-year component part warranty (all models)

OPERATING SPECIFICATIONS

- Radius: 103' to 165'
- Flow rate: 74.5 to 326.8 GPM
- Operating pressure range: 60 to 120 PSI
- Precipitation rate: 1.23 to 3.27 in/hr

USER INSTALLED OPTIONS

- Rubber Cover Kit ST-90: P/N 234200
- Rubber Cover Kit STG-900: P/N 473900



ST-90*

Overall height: 11½"
 Pop-up height: 3"
 Diameter: 5½"
 Inlet size: 1½" NPT
 * not for use with the ST Enclosure



STG-900*

Overall height: 14"
 Pop-up height: 3"
 Diameter: 8"
 Inlet size: 1½" Acme
 * for use with the ST173026B Enclosure



ST-1600B*

Overall height: 22½"
 Pop-up height: 5"
 Diameter: 14"
 Inlet size: 2" BSP**
 * for use with the ST243642B Enclosure
 ** use PN 241400 adapter to 2" pipe



ST-1600BR*

Overall height: 8¾"
 Diameter: 8¼"
 Inlet size: 2" BSP**
 * riser mounted model
 ** use PN 241400 adapter to 2" pipe

ST ROTOR MODELS

Model	Description
ST-90-73	3" pop-up, jar top cap, adjustable arc, plastic riser, NPT inlet threads, and 2 nozzles
STG-900-73	3" pop-up, top service, adjustable arc, plastic riser, ACME inlet threads, and 2 nozzles
ST-1600-B	5" pop-up, top service, adjustable arc, stainless riser, BSP* inlet threads, and 6 nozzles
ST-1600-BR	Riser mount, adjustable arc, BSP* inlet threads and 5 nozzles

* To adapt to 2" pipe use adapter P/N 241400

ST SYSTEM ACCESSORIES

ST SWING JOINTS

Multi-axis 315 PSI rated vertical alignment PVC swing joints with seven O-ring sealed pivot points allow the rotor to be perfectly placed within the ST Vault's cover set opening.



ST2008VA - 2" for ST-90, STG-900

Inlet: 2" Female Slip
Outlet: 1½" Female Acme



ST3010VA - 3" for ST-1600B

Inlet: 3" Female Slip
Outlet: 3" Female Acme

ST VALVE SETS

Heavy-duty control valves configured to complement the ST Rotors and ST Vaults.



STVBVFK - for STG-900 in STK-2 Kit

Valve: 1½" NPT ICV
Ball Valve: 315 PSI rated

Low Pressure Loss Design:
9.8 PSI at 100 GPM
Inlet: 1½" Acme
Outlet: 1½" Acme



STV30K - for ST-1600B in STK-6 Kit

Valve: 3" NPT ST-30

Low Pressure Loss Design:
2.0 PSI at 325 GPM
Inlet: 3" NPT
Outlet: 3" NPT

Slow Opening and Closing Feature
Remote On-Off-Auto Selector
(not shown)

ST VAULTS

Heavy-duty tapered fiberglass and polymer-concrete construction with pre-cast holes for rotor.



ST173026B - for STG-900 includes 2" thick 3-piece PC cover set

Main Cover: 17" x 30"
Overall Height: 26"
Body Weight: 104 lbs.
Total Weight: 161 lbs.
Base Pad: 27" x 41"
One Quick Access Port



ST243642B - for ST-1600 includes 3" thick 4-piece PC cover set

Main Cover: 24" x 36"
Overall Height: 42"
Body Weight: 170 lbs.
Total Weight: 320 lbs.
Base Pad: 44" x 50"
Two Quick Access Ports



① Quick Coupler

All ST Vaults include convenient quick access ports. Quick-couplers provide a convenient source of water for washing down spills and water-soluble paint. Integrated in-vault design eliminates the need for additional quick-coupler enclosures.



② On-Off-Auto Selector

The ST-V30K valve kit includes a remotely located On-Off-Auto selector and solenoid manifold assembly. These convenient features bring valve manual control functions and solenoid splice connections closer to the surface for easy access.

ST SYSTEM

KIT CONFIGURATIONS

STK-1 / STK-2

The ST Kits Descriptions

For specification ease and to ensure the correct product is installed, the ST System is available in kit configurations.

STK-1

STG-900 Block System
(remotely located valve)

STK-2

STG-900 VAH System
(valve adjacent to head)

ST Rotor: Synthetic Turf Rotor without rubber cover kit

STG-900**STG-900**

ST Vault: Vault with 3-piece polymer-concrete cover

ST-173026B**ST-173026B**

ST Swing Joint: "VA" 2" PVC Swing joint with 7 pivot points

ST-2008VA**ST-2008VA**

ST Valve & Fitting Kit: ICV-151 valve, high pressure rated ball valve and fitting kit

—

ST-VBVFk

ST Adapter Elbow Fitting*

239800**239800**

ST Rotor Adapter Fitting**

239300

—

Rubber Cover Kit: STG-900 Rubber Cover Kit

473900**473900**

Quick Coupler Valve: 1" inlet with 1/4" outlet for key

HQ5RC**HQ5RC****Notes:**

*ST Adapter Elbow Fitting connects ST-2008VA swing joint to rotor adapter fitting (STK-1) also connects ST-VBVFk to STG-900 rotor (STK-2)

** ST Rotor Adapter Fitting connects 239800 Adapter Elbow Fitting to STG-900 Acme inlet rotor (STK-1)

STK-5 / STK-6

The STK Kits Description

For specification ease and to ensure the correct product is installed, the ST System is available in kit configurations.

STK-5

ST-1600 Block System
(remotely located valve)

STK-6

ST-1600 VAH System
(valve adjacent to head)

ST Rotor: Synthetic Turf Rotor

ST-1600B**ST-1600B**

ST Vault: Vault with 4-piece polymer-concrete cover set

ST-243642B**ST-243642B**

ST Swing Joint: 3" PVC Swing Joint with 7 pivot points (315 PSI rated)

ST-3010VA**ST-3010VA**

ST Valve Sets: 3" Valve Set with remote on-off-auto selector manifold

—

ST-V30K

ST Fitting Sets: All fittings needed to connect swing joint to valve and/or rotor

ST-F30K**ST-F30K**

Quick Coupler Valve: 1" inlet with 1/4" outlet for key

HQ5RC**HQ5RC**

ST-1600 NOZZLE PERFORMANCE DATA

Nozzle	Pressure (PSI)	Radius (FT.)	Flow (GPM)	Precip in/hr	
				■	▲
16 ●	60	107	96.2	1.63	1.88
	75	115	107.3	1.57	1.81
	90	121	117.8	1.54	1.78
	105	128	127.3	1.50	1.73
	120	135	137.4	1.46	1.69
Black					
18 ●	60	112	107.0	1.66	1.91
	75	121	119.4	1.56	1.80
	90	128	131.0	1.54	1.78
	105	133	141.3	1.54	1.78
	120	141	153.2	1.48	1.71
Black					
20 ●	60	115	144.0	2.10	2.43
	75	128	160.9	1.89	2.18
	90	141	176.5	1.71	1.97
	105	144	190.5	1.76	2.03
	120	148	204.2	1.80	2.08
Black					
22 ●	60	118	171.5	2.37	2.73
	75	130	191.8	2.20	2.54
	90	144	210.0	1.94	2.24
	105	151	226.9	1.84	2.12
	120	155	243.1	1.89	2.18
Black					
24 ●	60	121	202.1	2.64	3.05
	75	133	225.9	2.46	2.84
	90	148	247.6	2.19	2.52
	105	156	267.4	2.12	2.45
	120	160	286.4	2.16	2.49
Black					
26* ●	60	126	233.2	2.83	3.27
	75	136	260.4	2.71	3.13
	90	151	284.5	2.40	2.77
	105	160	307.0	2.31	2.67
	120	165	326.8	2.32	2.68
Black					

* Preliminary data

ST-90 / STG-900 NOZZLE PERFORMANCE DATA

Nozzle	Pressure (PSI)	Radius (FT.)	Flow (GPM)	Precip in/hr	
				■	▲
73 ●	100	103	74.5	1.35	1.56
	110	109	77.0	1.25	1.44
	120	115	79.6	1.16	1.34
Orange					
83 ●	100	112	84.2	1.29	1.49
	110	116	88.1	1.26	1.46
	120	120	92.0	1.23	1.42
Tan					

Notes:

All precipitation rates calculated for 180 degree operation. For precipitation rate of 360 degree sprinkler divide by 2.

INSTALLATION DETAILS

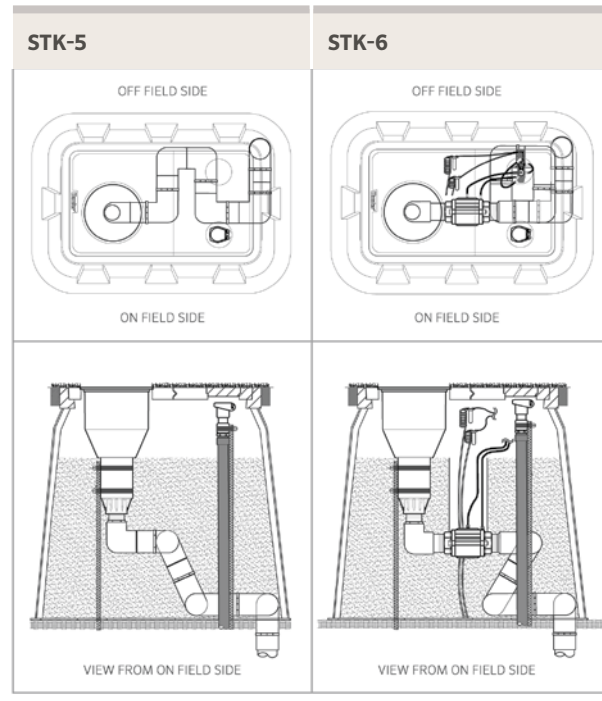
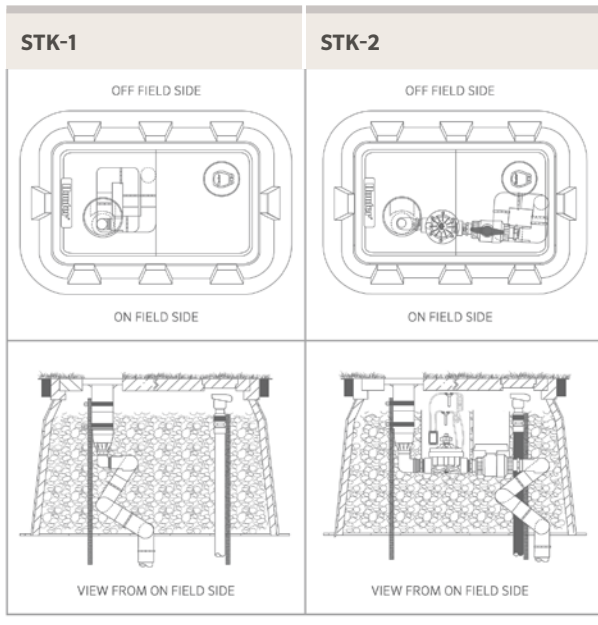

SPRAYS

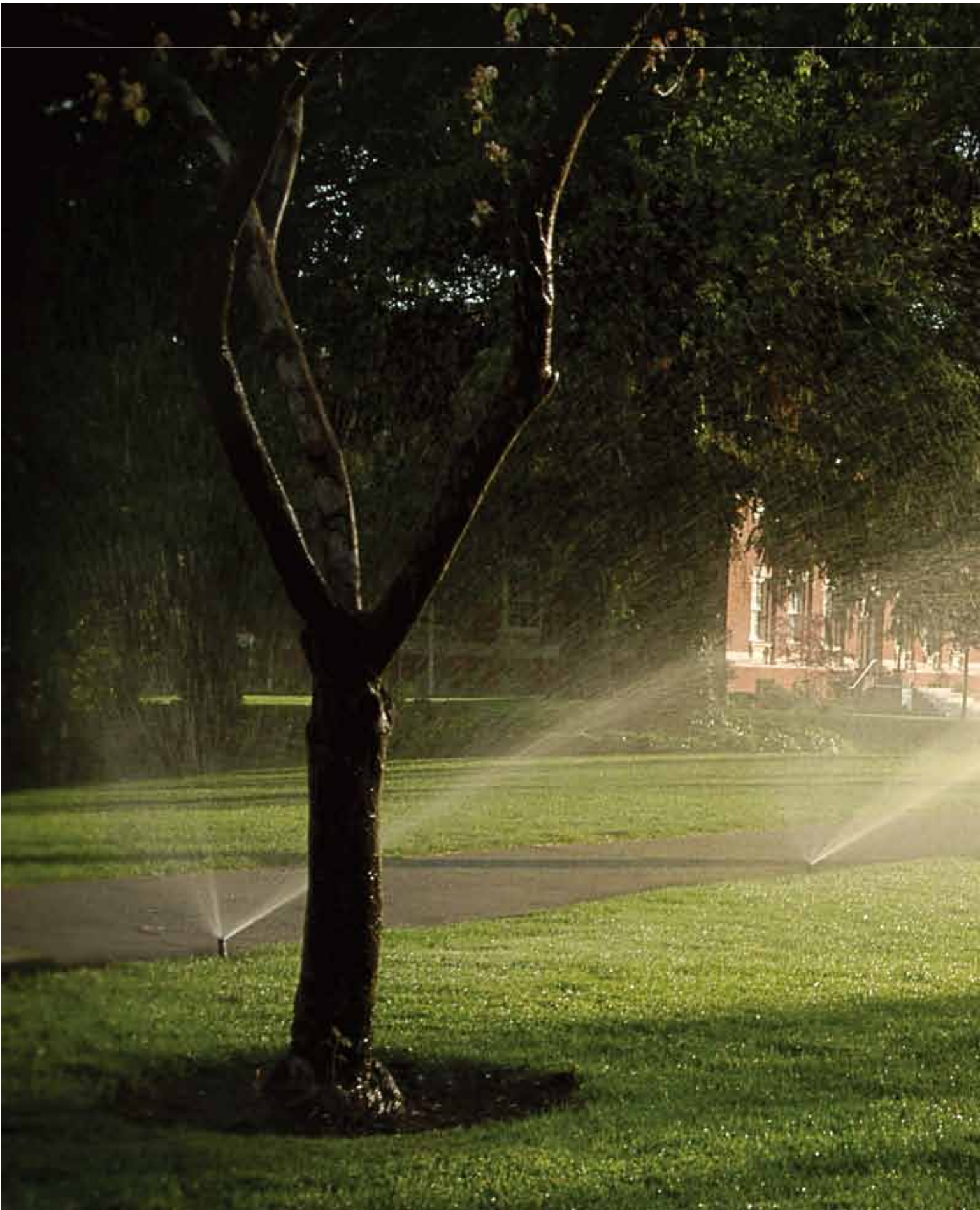

SPRAYS

Comparison Chart

	PS ULTRA	PRO-SPRAY®	PRS30	PRS40
APPLICATIONS				
Turfgrass	•	•	•	•
Turfgrass: Tall mowing height	•	•	•	•
Ground cover	•	•	•	•
Shrubs: Sprinklers on risers	•	•	•	•
Shrubs: Tall pop-up sprinklers		•	•	•
Residential	•	•	•	•
Commercial		•	•	•
High traffic areas		•	•	•
Reclaimed water		•	•	•
Field-installed check valve options	•	•	•	•
Factory-installed check valve options		•	•	•
Pressure regulation			•	•

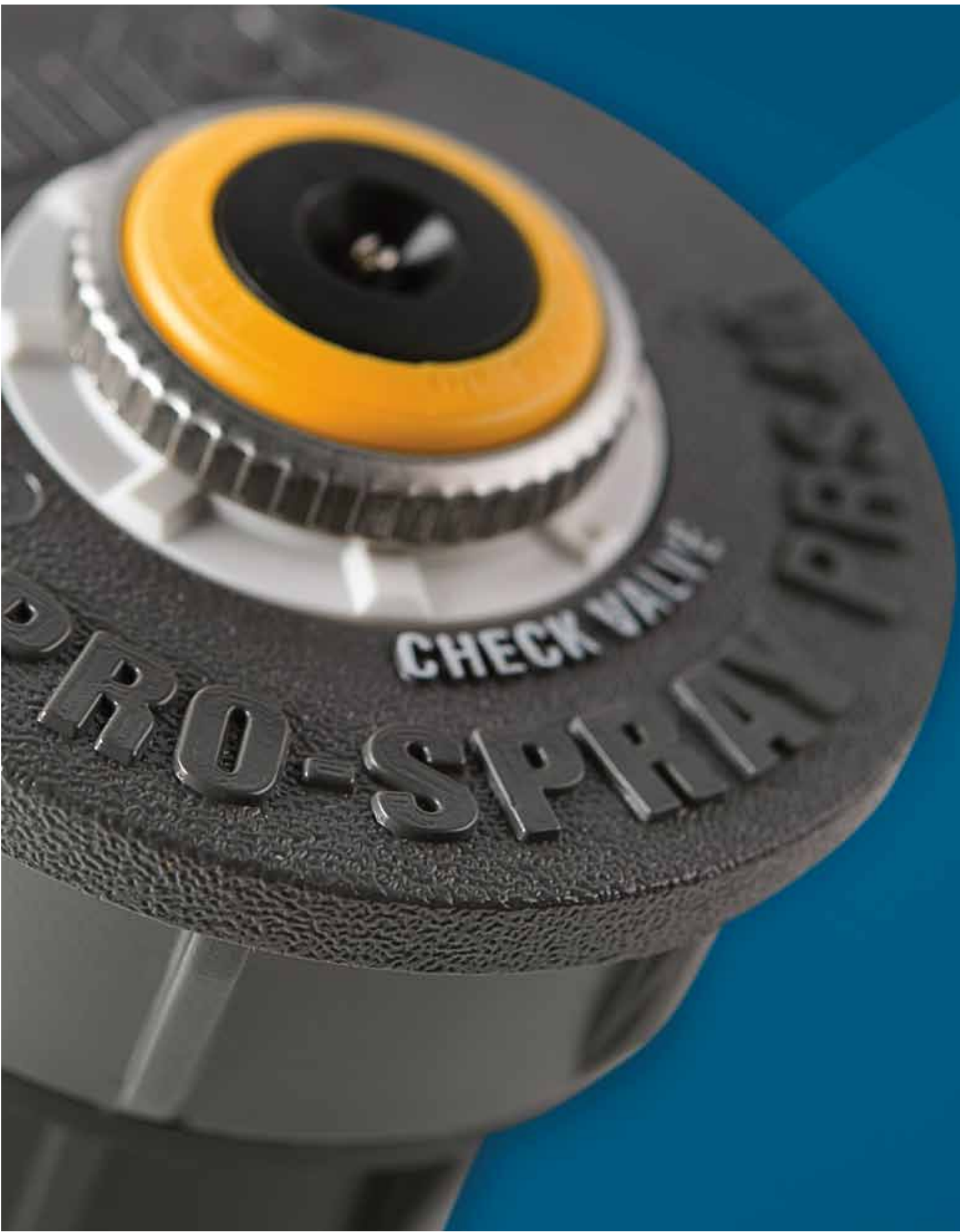

ADVANCED FEATURES

Co-Molded Wiper Seal

This pressure-activated, multi-function wiper seal was designed to reduce flow-by. The zero flush seal operates at low pressures and allows more sprinkler heads on the same zone. The wiper seal's design protects the riser when operating, and keeps debris out of the seal when retracted, reducing riser stick-ups.



Pro-Spray Check Valve

Optional check valves eliminate leaks and puddles at the lower heads, protecting landscapes from damage and erosion while reducing water waste. Choose from the convenience of factory-installed check valves or the flexibility of field installation.



Heavy-Duty Spring

The strongest retraction spring for positive retraction under any conditions.



Pressure Regulated to 30 & 40 PSI

Hunter's pressure regulated pop-up sprays are calibrated for the needs of any installation. The PRS30 with the brown cap optimizes performance of your traditional sprays at 2.1 bar 30 PSI. The grey-capped PRS40 is designed for the efficient MP Rotator and is the only 40 PSI regulated pop-up on the market today.



Body Cap Won't Leak Under High Pressure

The Pro-Spray line incorporates a heavy-duty ribbed body and durable cap engineered to withstand the harshest environments, including the rigors of foot traffic and the abuses of heavy machinery. In addition, a multi-thread buttress design provides superior strength in cap-to-body gripping capacity helping the head to withstand high inlet surge pressures.



Competitor

Pro-Spray

PS ULTRA

Application: **Residential**
 Size: **2", 4", 6"**

FEATURES

- Application: Residential
- Models: 2", 4", 6"
- Nozzle choices: 5
- Flow rate: 0.2 to 5.6 GPM
- Nozzle choices: 10A, 12A, 15A, 17A, 5' x 30' side strip (side strip pattern available on 2" and 4" models only)
- Preinstalled Pro Adjustable nozzle
- Enhanced cap for more durability, easier handling, and extended riser seal life
- 2" and 4" models can retro-fit into older style PS sprays
- Two-piece ratchet
- Male threaded riser to accept all female nozzles
- Available with flush plug (large filter screen not included)
- Extra large filter screen
- Warranty period: 2 years

OPERATING SPECIFICATIONS

- Flow rate: 0.2 to 5.6 GPM
- Radius: 9' to 19'
- Recommended pressure range: 20 to 70 PSI
- Precipitation rates: 1.6 to 1.9 in/hr approx.

FACTORY INSTALLED OPTIONS

- Nozzles: 10A, 12A, 15A, 17A, 5' x 30' side strip
- Flush plug (large filter screen not included)

USER INSTALLED OPTIONS

- Drain check valve: 4" and 6" models (up to 7' of elevation; P/N 462237)
- Large basket filter screen (replacement; P/N 162900)



PSU02
 Overall height: 5"
 Pop-up height: 2"
 Exposed diameter: 1/4"
 Inlet size: 1/2" Female NPT



PSU04
 Overall height: 7 1/4"
 Pop-up height: 4"
 Exposed diameter: 1/4"
 Inlet size: 1/2" Female NPT



PSU06
 Overall height: 9 1/2"
 Pop-up height: 6"
 Exposed diameter: 1/4"
 Inlet size: 1/2" Female NPT

PS ULTRA - SPECIFICATION BUILDER: ORDER 1 + 2

1 Models	2 Radius
PSU-02 = 2' Pop-up	(blank) = No option
PSU-04 = 4' Pop-up	10A = 10' Adjustable nozzle
PSU-06 = 6' Pop-up	12A = 12' Adjustable nozzle
	15A = 15' Adjustable nozzle
	17A = 17' Adjustable nozzle
	5SS = 5' x 30' Side Strip (2" and 4" only)

Examples:

- PSU-04 - 15A = 4" pop-up, with a 15' adjustable nozzle
- PSU-02 - 5SS = 2" pop-up, with a 5' x 30' side strip
- PSU-06 - 10A = 6" pop-up, with a 10' adjustable nozzle
- PSU-04 = 4" pop-up, with flush plug, large filter screen not included







PS ULTRA STANDARD NOZZLES PERFORMANCE DATA

● Nozzle 10A Red
 10 foot radius
 Adjustable from 0° to 360°
 Trajectory: 15°

● Nozzle 12A Green
 12 foot radius
 Adjustable from 0° to 360°
 Trajectory: 28°

● Nozzle 15A Black
 15 foot radius
 Adjustable from 0° to 360°
 Trajectory: 28°

● Nozzle 17A Gray
 17 foot radius
 Adjustable from 0° to 360°
 Trajectory: 28°

Arc	Pressure (PSI)	Nozzle 10A Red				Nozzle 12A Green				Nozzle 15A Black				Nozzle 17A Gray			
		Radius (FT.)	Flow (GPM)	Precip in/hr ■	Precip in/hr ▲	Radius (FT.)	Flow (GPM)	Precip in/hr ■	Precip in/hr ▲	Radius (FT.)	Flow (GPM)	Precip in/hr ■	Precip in/hr ▲	Radius (FT.)	Flow (GPM)	Precip in/hr ■	Precip in/hr ▲
45° 	20	9	0.20	1.86	2.15	11	0.25	1.60	1.85	14	0.37	1.46	1.69	16	0.48	1.44	1.67
	25	10	0.22	1.71	1.97	12	0.28	1.52	1.76	15	0.42	1.44	1.66	17	0.54	1.45	1.67
	30	10	0.25	1.89	2.18	12	0.32	1.68	1.95	15	0.47	1.59	1.84	17	0.60	1.60	1.85
	35	11	0.27	1.70	1.96	13	0.34	1.56	1.80	16	0.51	1.52	1.76	18	0.65	1.55	1.79
	40	11	0.29	1.83	2.11	13	0.37	1.68	1.94	17	0.54	1.45	1.68	19	0.70	1.50	1.73
90° 	20	9	0.39	1.86	2.15	11	0.50	1.60	1.85	14	0.74	1.46	1.69	16	0.96	1.44	1.67
	25	10	0.44	1.71	1.97	12	0.57	1.52	1.76	15	0.84	1.44	1.66	17	1.09	1.45	1.67
	30	10	0.49	1.89	2.18	12	0.63	1.68	1.95	15	0.93	1.59	1.84	17	1.20	1.60	1.85
	35	11	0.53	1.70	1.96	13	0.69	1.56	1.80	16	1.01	1.52	1.76	18	1.31	1.55	1.79
	40	11	0.57	1.83	2.11	13	0.74	1.68	1.94	17	1.09	1.45	1.68	19	1.41	1.50	1.73
120° 	20	9	0.52	1.86	2.15	11	0.67	1.60	1.85	14	0.99	1.46	1.69	16	1.28	1.44	1.67
	25	10	0.59	1.71	1.97	12	0.76	1.52	1.76	15	1.12	1.44	1.66	17	1.45	1.45	1.67
	30	10	0.65	1.89	2.18	12	0.84	1.68	1.95	15	1.24	1.59	1.84	17	1.60	1.60	1.85
	35	11	0.71	1.70	1.96	13	0.91	1.56	1.80	16	1.35	1.52	1.76	18	1.74	1.55	1.79
	40	11	0.77	1.83	2.11	13	0.98	1.68	1.94	17	1.45	1.45	1.68	19	1.87	1.50	1.73
180° 	20	9	0.78	1.86	2.15	11	1.01	1.60	1.85	14	1.49	1.46	1.69	16	1.92	1.44	1.67
	25	10	0.89	1.71	1.97	12	1.14	1.52	1.76	15	1.68	1.44	1.66	17	2.17	1.45	1.67
	30	10	0.98	1.89	2.18	12	1.26	1.68	1.95	15	1.86	1.59	1.84	17	2.40	1.60	1.85
	35	11	1.07	1.70	1.96	13	1.37	1.56	1.80	16	2.02	1.52	1.76	18	2.61	1.55	1.79
	40	11	1.15	1.83	2.11	13	1.48	1.68	1.94	17	2.18	1.45	1.68	19	2.81	1.50	1.73
240° 	20	9	1.05	1.86	2.15	11	1.34	1.60	1.85	14	1.98	1.46	1.69	16	2.56	1.44	1.67
	25	10	1.18	1.71	1.97	12	1.52	1.52	1.76	15	2.24	1.44	1.66	17	2.89	1.45	1.67
	30	10	1.31	1.89	2.18	12	1.68	1.68	1.95	15	2.48	1.59	1.84	17	3.20	1.60	1.85
	35	11	1.42	1.70	1.96	13	1.83	1.56	1.80	16	2.7	1.52	1.76	18	3.48	1.55	1.79
	40	11	1.53	1.83	2.11	13	1.97	1.68	1.94	17	2.91	1.45	1.68	19	3.75	1.50	1.73
270° 	20	9	1.18	1.86	2.15	11	1.51	1.60	1.85	14	2.23	1.46	1.69	16	2.88	1.44	1.67
	25	10	1.33	1.71	1.97	12	1.71	1.52	1.76	15	2.52	1.44	1.66	17	3.26	1.45	1.67
	30	10	1.47	1.89	2.18	12	1.89	1.68	1.95	15	2.79	1.59	1.84	17	3.60	1.60	1.85
	35	11	1.60	1.70	1.96	13	2.06	1.56	1.80	16	3.04	1.52	1.76	18	3.92	1.55	1.79
	40	11	1.72	1.83	2.11	13	2.21	1.68	1.94	17	3.27	1.45	1.68	19	4.22	1.50	1.73
360° 	20	9	1.57	1.86	2.15	11	2.02	1.60	1.85	14	2.98	1.46	1.69	16	3.84	1.44	1.67
	25	10	1.77	1.71	1.97	12	2.28	1.52	1.76	15	3.37	1.44	1.66	17	4.34	1.45	1.67
	30	10	1.96	1.89	2.18	12	2.52	1.68	1.95	15	3.72	1.59	1.84	17	4.80	1.60	1.85
	35	11	2.13	1.70	1.96	13	2.74	1.56	1.80	16	4.05	1.52	1.76	18	5.22	1.55	1.79
	40	11	2.30	1.83	2.11	13	2.95	1.68	1.94	17	4.36	1.45	1.68	19	5.62	1.50	1.73

Bold = Recommended pressure

STRIP PATTERN NOZZLE PERFORMANCE DATA

Nozzle Model	Pressure (PSI)	Width x Length	Flow (GPM)
	20	4 X 28	1.10
	25	5 X 30	1.20
	30	5 X 30	1.30
	35	5 X 30	1.40
	40	5 X 30	1.50

Bold = Recommended pressure

PRO-SPRAY®

Application: **Residential/Commercial**
 Models: **Shrub, 2", 3", 4", 6", 12"**

FEATURES

- Application: Residential/Commercial
- Models: Shrub, 2", 3", 4", 6", 12"
- Compatible with all female threaded nozzles
- No side inlet (NSI) version available in 6" and 12"
- Warranty period: 5 years
- ▶ Co-molded wiper seal
- ▶ Body cap won't leak under high pressure
- ▶ Heavy-duty spring

OPERATING SPECIFICATIONS

- Recommended pressure range: 15 to 100 PSI

FACTORY INSTALLED OPTIONS

- Drain check valve (up to 10 ft. of elevation)
- Check valve available on 4", 6", 12"
- Reclaimed water ID cap

USER INSTALLED OPTIONS

- Drain check valve (up to 10 ft. of elevation; P/N 437400)
- Reclaimed water ID cap (P/N 458520)
- Snap-on reclaimed cover (P/N PROSRCCAP)

▶ = Advanced Feature descriptions on page 36



Pro-Spray Reclaimed

Pro-Spray models come with optional factory-installed purple reclaimed caps.



Related Solutions: Works Best With

Pro-Spray works best with MP Rotator, Pro-Spray Fixed Arc Nozzles and Pro Adjustable Nozzles.



PROS-00
 Overall height: 1½"
 Inlet size: ½" Female NPT



PROS-02
 Overall height: 4"
 Pop-up height: 2"
 Exposed diameter: 2 ¼"
 Inlet size: ½" Female NPT



PROS-03
 Overall height: 5"
 Pop-up height: 3"
 Exposed diameter: 2¼"
 Inlet size: ½" Female NPT



PROS-04
 Overall height: 5⅞"
 Pop-up height: 4"
 Exposed diameter: 2¼"
 Inlet size: ½" Female NPT



A] **PROS-06**
 B] **PROS-06-NSI**
 Overall height: 8 ¾"
 Pop-up height: 6"
 Exposed diameter: 2¼"
 Inlet size: ½" Female NPT



A] **PROS-12**
 B] **PROS-12-NSI**
 Overall height: 16⅞"
 Pop-up height: 12"
 Exposed diameter: 2¼"
 Inlet size: ½" Female NPT

PRO-SPRAY® - SPECIFICATION BUILDER: ORDER 1 + 2

1 Models	2 Options
PROS-00 = Shrub Adapter	(blank) = No option
PROS-02 = 2" Pop-up	CV = Factory-installed drain check valve (Pop-up models only, 6" and 12" models ordered as CV will come as no side inlet)
PROS-03 = 3" Pop-up	CV-R = Factory-installed reclaimed body cap (Shrub molded in purple)
PROS-04 = 4" Pop-up	
PROS-06 = 6" Pop-up	
PROS-06-NSI = 6" Pop-up (no side inlet)	
PROS-12 = 12" Pop-up	
PROS-12-NSI = 12" Pop-up (no side inlet)	

Examples:

- PROS-04 - 10A = 4" pop-up, and 10' adjustable nozzle
- PROS-06 - CV - 12H = 6" pop-up, drain check valve, and 12' half circle nozzle
- PROS-12 - CV-R - RCS-515 = 12" pop-up, drain check valve, reclaimed body cap, and right corner strip

PRS30

PRESSURE REGULATED

Application: **Residential/Commercial**

Models: **Shrub, 4", 6", 12"**

Pressure Regulated at: **30 PSI**

FEATURES

- Application: Residential/Commercial
- Models: Shrub, 4", 6", 12"
- Pressure regulated at 30 PSI
- No side inlet (NSI) version available in 6" and 12"
- Identification cap is brown for easy field ID
- Warranty period: 5 years
- ▶ Co-molded wiper seal
- ▶ Body cap won't leak under high pressure
- ▶ Heavy-duty spring

OPERATING SPECIFICATIONS

- Recommended pressure range: 15 to 100 PSI

FACTORY INSTALLED OPTIONS

- Drain check valve (up to 14 ft. of elevation)
- Check valve available on 4", 6", 12"
- Reclaimed water ID cap

USER INSTALLED OPTIONS

- Vandal-proof cap (P/N PROS-PRS30-VPC)
- Drain check valve (up to 14 ft. of elevation; P/N 457400)
- Reclaimed water ID cap (P/N 458560)
- Snap-on reclaimed cover (P/N PROSRCCAP)

▶ = Advanced Feature descriptions on page 36



PRS30 Reclaimed

PRS30 models come with optional factory-installed purple reclaimed caps.



Related Solutions: Works Best With

PRS30 works best with Pro-Spray Fixed Arc Nozzles and Pro Adjustable Nozzles.



PROS-00-PRS30

Overall height: 4½"
Inlet size: ½" Female NPT



PROS-04-PRS30

Overall height: 5⅞"
Pop-up height: 4"
Exposed diameter: 2¼"
Inlet size: ½" Female NPT



[A]



[B]

A] PROS-06-PRS30

B] PROS-06-NSI-PRS30

Overall height: 8¾"
Pop-up height: 6"
Exposed diameter: 2¼"
Inlet size: ½" Female NPT



[A]



[B]

A] PROS-12-PRS30

B] PROS-12-NSI-PRS30

Overall height: 16⅞"
Pop-up height: 12"
Exposed diameter: 2¼"
Inlet size: ½" Female NPT

SPRAYS

PRS30 - SPECIFICATION BUILDER: ORDER 1 + 2

1 Models	2 Options
PROS-00-PRS30 = 30 PSI regulated shrub adapter	(blank) = No option
PROS-04-PRS30 = 30 PSI regulated 4" pop-up	CV = Factory-installed drain check valve (Pop-up models only, 6" and 12" models ordered as CV will come as no side inlet)
PROS-06-PRS30 = 30 PSI regulated 6" pop-up	CV-R = Factory-installed reclaimed body cap (Shrub molded in purple)
PROS-06-NSI-PRS30 = 30 PSI regulated 6" pop-up (no side inlet)	
PROS-12-PRS30 = 30 PSI regulated 12" pop-up	
PROS-12-NSI-PRS30 = 30 PSI regulated 12" pop-up (no side inlet)	

Examples:

PROS-04-PRS30 = 4" pop-up regulated at 30 PSI

PROS-06-PRS30 - CV - 12H = 6" pop-up regulated at 30 PSI, drain check valve, and 12 ft. half circle nozzle

PROS-12-PRS30 - CV-R - 10A = 12" pop-up regulated at 30 PSI, drain check valve, reclaimed body cap, and 10' adjustable nozzle

PRS40

PRESSURE REGULATED

Application: **Residential/Commercial**

Models: **Shrub, 4", 6", 12"**

Pressure Regulated at: **40 PSI**

FEATURES

- Application: Residential/commercial
- Models: Shrub, 4", 6", 12"
- Pressure regulated at 40 PSI
- Identification cap is grey for easy field ID
- Innovative directional flush plug design
- 6" and 12" models come standard as no side inlet ensuring proper installation with check valve
- Drain check valve installed (up to 14 ft. of elevation)
- Warranty period: 5 years
- ▶ Co-molded wiper seal
- ▶ Body cap won't leak under high pressure
- ▶ Heavy-duty spring

OPERATING SPECIFICATIONS

- Recommended pressure range: 15 to 100 PSI

FACTORY INSTALLED OPTIONS

- Reclaimed water ID cap

USER INSTALLED OPTIONS

- Reclaimed water ID cap (P/N 458562)
- Snap-on reclaimed cover (P/N PROSRCCAP)

▶ = Advanced Feature descriptions on page 36



PRS40 Reclaimed

PRS40 models come with optional factory-installed purple reclaimed caps.



Related Solutions: MP Rotator

PRS40 is designed specifically for the MP Rotator.



PROS-00-PRS40

Overall height: 4½"
Inlet size: ½" Female NPT



PROS-04-PRS40-CV

Overall height: 5½"
Pop-up height: 4"
Exposed diameter: 2¼"
Inlet size: ½" Female NPT



PROS-06-PRS40-CV

Overall height: 8¾"
Pop-up height: 6"
Exposed diameter: 2¼"
Inlet size: ½" Female NPT



PROS-12-PRS40-CV

Overall height: 16⅞"
Pop-up height: 12"
Exposed diameter: 2¼"
Inlet size: ½" Female NPT

PRS40 - SPECIFICATION BUILDER: ORDER 1 + 2

1 Models	2 Options
PROS-00-PRS40 = 40 PSI regulated shrub adapter	(blank) = No option
PROS-04-PRS40-CV = 40 PSI regulated 4" pop-up	R = Factory-installed reclaimed body cap (Shrub molded in purple)
PROS-06-PRS40-CV = 40 PSI regulated 6" pop-up	
PROS-12-PRS40-CV = 40 PSI regulated 12" pop-up	

Examples:

- PROS-04-PRS40-CV = 4" pop-up regulated at 40 PSI, drain check valve
- PROS-06-PRS40-CV = 6" pop-up regulated at 40 PSI, drain check valve
- PROS-12-PRS40-CV - R = 12" pop-up regulated at 40 PSI, drain check valve, reclaimed body cap
- PROS-06-PRS40-CV - MP200090 = 6" pop-up regulated at 40 PSI, drain check valve, with MP 2000 90-210°

NOZZLES



NOZZLES

PRO ADJUSTABLE NOZZLES

FEATURES

- Crisp, well-defined edges
- Matched precipitation rate from 8 ft. to 17 ft.
- Easy grip top for simple adjustment
- Designed with large water droplets to withstand light winds
- Even distribution results in beautiful pattern
- 4 ft. and 6 ft. Pro Adjustable Nozzles provide additional flexibility
- Color-coded for easy field identification
- Adjustable from 0° to 360°

OPERATING SPECIFICATIONS

- Recommended operating pressure: 30 PSI
- Specify the new Pro-Spray® PRS30 pop-up for accurate pressure regulation of 30 PSI



4A Nozzle
Radius: 4'



6A Nozzle
Radius: 6'



8A Nozzle
Radius: 8'



10A Nozzle
Radius: 10'



12A Nozzle
Radius: 12'



15A Nozzle
Radius: 15'



17A Nozzle
Radius: 17'

PRO ADJUSTABLE NOZZLES PERFORMANCE DATA

● Nozzle 4A Lt. Green
4 ft. radius
Adjustable from 0° to 360°
Trajectory: 0°

● Nozzle 6A Lt. Blue
6 ft. radius
Adjustable from 0° to 360°
Trajectory: 0°

● Nozzle 8A Brown
8 ft. radius
Adjustable from 0° to 360°
Trajectory: 0°

● Nozzle 10A Red
10 ft. radius
Adjustable from 0° to 360°
Trajectory: 15°

Arc	Pressure (PSI)	Nozzle 4A Lt. Green				Nozzle 6A Lt. Blue				Nozzle 8A Brown				Nozzle 10A Red			
		Radius (FT.)	Flow (GPM)	Precip in/hr ■	Precip in/hr ▲	Radius (FT.)	Flow (GPM)	Precip in/hr ■	Precip in/hr ▲	Radius (FT.)	Flow (GPM)	Precip in/hr ■	Precip in/hr ▲	Radius (FT.)	Flow (GPM)	Precip in/hr ■	Precip in/hr ▲
45° ▶	20	3	0.11	5.44	6.28	5	0.15	3.21	3.70	7	0.12	1.83	2.11	9	0.20	1.86	2.15
	25	3	0.13	6.02	6.95	5	0.15	3.21	3.70	8	0.13	1.58	1.83	10	0.22	1.71	1.97
	30	4	0.13	6.45	7.45	6	0.18	3.85	4.45	8	0.15	1.75	2.02	10	0.25	1.89	2.18
	35	4	0.14	6.74	7.78	6	0.18	3.85	4.45	9	0.16	1.51	1.74	11	0.27	1.70	1.96
90° ◑	20	3	0.19	4.57	5.28	5	0.3	3.21	3.70	7	0.23	1.83	2.11	9	0.39	1.86	2.15
	25	3	0.20	4.81	5.56	5	0.31	3.32	3.83	8	0.26	1.58	1.83	10	0.44	1.71	1.97
	30	4	0.28	6.74	7.78	6	0.37	3.96	4.57	8	0.29	1.75	2.02	10	0.49	1.89	2.18
	35	4	0.24	5.78	6.67	6	0.38	4.06	4.69	9	0.32	1.51	1.74	11	0.53	1.70	1.96
120° ◐	20	3	0.28	5.05	5.84	5	0.37	2.97	3.43	7	0.31	1.83	2.11	9	0.52	1.86	2.15
	25	3	0.30	5.32	6.15	5	0.38	3.05	3.52	8	0.35	1.58	1.83	10	0.59	1.71	1.97
	30	4	0.34	6.14	7.09	6	0.44	3.53	4.08	8	0.39	1.75	2.02	10	0.65	1.89	2.18
	35	4	0.34	6.14	7.09	6	0.46	3.69	4.26	9	0.42	1.51	1.74	11	0.71	1.70	1.96
180° ◐	20	3	0.34	4.09	4.72	5	0.5	2.67	3.09	7	0.47	1.83	2.11	9	0.78	1.86	2.15
	25	3	0.38	4.57	5.28	5	0.54	2.89	3.33	8	0.53	1.58	1.83	10	0.89	1.71	1.97
	30	4	0.45	5.41	6.25	6	0.6	3.21	3.70	8	0.58	1.75	2.02	10	0.98	1.89	2.18
	35	4	0.46	5.53	6.39	6	0.64	3.42	3.95	9	0.63	1.51	1.74	11	1.07	1.70	1.96
240° ◑	20	3	0.58	5.23	6.04	5	0.73	2.93	0.85	7	0.62	1.83	2.11	9	1.05	1.86	2.15
	25	3	0.62	5.59	6.46	5	0.78	3.13	0.90	8	0.70	1.58	1.83	10	1.18	1.71	1.97
	30	4	0.38	6.13	3.96	6	0.88	3.53	1.02	8	0.78	1.75	2.02	10	1.31	1.89	2.18
	35	4	0.74	6.68	7.71	6	0.92	3.69	1.07	9	0.84	1.51	1.74	11	1.42	1.70	1.96
270° ◑	20	3	0.59	4.73	5.46	4	0.88	3.14	3.62	7	0.70	1.83	2.11	9	1.18	1.86	2.15
	25	3	0.66	5.29	6.11	5	0.98	3.49	4.03	8	0.79	1.58	1.83	10	1.33	1.71	1.97
	30	4	0.73	5.86	6.76	6	1.1	3.92	4.53	8	0.87	1.75	2.02	10	1.47	1.89	2.18
	35	4	0.76	6.10	7.04	6	1.15	4.1	4.73	9	0.95	1.51	1.74	11	1.60	1.70	1.96
360° ●	20	3	0.66	3.97	4.58	4	1.05	2.81	3.24	7	0.93	1.83	2.11	9	1.57	1.86	2.15
	25	3	0.72	4.33	5.00	5	1.1	2.94	3.40	8	1.05	1.58	1.83	10	1.77	1.71	1.97
	30	4	0.80	4.81	5.56	6	1.26	3.37	3.89	8	1.16	1.75	2.02	10	1.96	1.89	2.18
	35	4	0.86	5.17	5.97	6	1.3	3.48	4.01	9	1.27	1.51	1.74	11	2.13	1.70	1.96
40	4	0.90	5.41	6.25	6	1.4	3.74	4.32	9	1.36	1.62	1.87	11	2.30	1.83	2.11	

Bold = Recommended pressure

Pro Adjustable Nozzle









NOZZLES

PRO ADJUSTABLE NOZZLES PERFORMANCE DATA

● Nozzle 12A Green
12 ft. radius
Adjustable from 0° to 360°
Trajectory: 28°

● Nozzle 15A Black
15 ft. radius
Adjustable from 0° to 360°
Trajectory: 28°

● Nozzle 17A Gray
17 ft. radius
Adjustable from 0° to 360°
Trajectory: 28°

Arc	Pressure (PSI)	Nozzle 12A Green			Nozzle 15A Black			Nozzle 17A Gray					
		Radius (FT.)	Flow (GPM)	Precip in/hr	Radius (FT.)	Flow (GPM)	Precip in/hr	Radius (FT.)	Flow (GPM)	Precip in/hr			
45° 	20	11	0.25	1.60	1.85	14	0.37	1.46	1.69	16	0.48	1.44	1.67
	25	12	0.28	1.52	1.76	15	0.42	1.44	1.66	17	0.54	1.45	1.67
	30	12	0.32	1.68	1.95	15	0.47	1.59	1.84	17	0.60	1.60	1.85
	35	13	0.34	1.56	1.80	16	0.51	1.52	1.76	18	0.65	1.55	1.79
90° 	20	11	0.50	1.60	1.85	14	0.74	1.46	1.69	16	0.96	1.44	1.67
	25	12	0.57	1.52	1.76	15	0.84	1.44	1.66	17	1.09	1.45	1.67
	30	12	0.63	1.68	1.95	15	0.93	1.59	1.84	17	1.20	1.60	1.85
	35	13	0.69	1.56	1.80	16	1.01	1.52	1.76	18	1.31	1.55	1.79
120° 	20	11	0.67	1.60	1.85	14	0.99	1.46	1.69	16	1.28	1.44	1.67
	25	12	0.76	1.52	1.76	15	1.12	1.44	1.66	17	1.45	1.45	1.67
	30	12	0.84	1.68	1.95	15	1.24	1.59	1.84	17	1.60	1.60	1.85
	35	13	0.91	1.56	1.80	16	1.35	1.52	1.76	18	1.74	1.55	1.79
180° 	20	11	1.01	1.60	1.85	14	1.49	1.46	1.69	16	1.92	1.44	1.67
	25	12	1.14	1.52	1.76	15	1.68	1.44	1.66	17	2.17	1.45	1.67
	30	12	1.26	1.68	1.95	15	1.86	1.59	1.84	17	2.40	1.60	1.85
	35	13	1.37	1.56	1.80	16	2.02	1.52	1.76	18	2.61	1.55	1.79
240° 	20	11	1.34	1.60	1.85	14	1.98	1.46	1.69	16	2.56	1.44	1.67
	25	12	1.52	1.52	1.76	15	2.24	1.44	1.66	17	2.89	1.45	1.67
	30	12	1.68	1.68	1.95	15	2.48	1.59	1.84	17	3.20	1.60	1.85
	35	13	1.83	1.56	1.80	16	2.70	1.52	1.76	18	3.48	1.55	1.79
270° 	20	11	1.51	1.60	1.85	14	2.23	1.46	1.69	16	2.88	1.44	1.67
	25	12	1.71	1.52	1.76	15	2.52	1.44	1.66	17	3.26	1.45	1.67
	30	12	1.89	1.68	1.95	15	2.79	1.59	1.84	17	3.60	1.60	1.85
	35	13	2.06	1.56	1.80	16	3.04	1.52	1.76	18	3.92	1.55	1.79
360° 	20	11	2.02	1.60	1.85	14	2.98	1.46	1.69	16	3.84	1.44	1.67
	25	12	2.28	1.52	1.76	15	3.37	1.44	1.66	17	4.34	1.45	1.67
	30	12	2.52	1.68	1.95	15	3.72	1.59	1.84	17	4.80	1.60	1.85
	35	13	2.74	1.56	1.80	16	4.05	1.52	1.76	18	5.22	1.55	1.79
	40	13	2.95	1.68	1.94	17	4.36	1.45	1.68	19	5.62	1.50	1.73

Bold = Recommended pressure

NOZZLES

PRO-SPRAY® FIXED ARC NOZZLES

FEATURES

- Color-coded for easy field identification
- Optimum droplet size minimizes misting while maximizing uniformity
- 1/3, 2/3, and 3/4 arc options for increased flexibility

OPERATING SPECIFICATIONS

- Recommended operating pressure: 30 PSI
- Specify the Pro-Spray® PRS30 pop-up for accurate pressure regulation of 30 PSI







PRO-SPRAY® NOZZLES						
ARC	5	8	10	12	15	17
Q						
T	Use 4A/6A Nozzle					Use 17A Nozzle
H						
TT	Use 4A/6A Nozzle	Use 8A Nozzle	Use 10A Nozzle			Use 17A Nozzle
TQ	Use 4A/6A Nozzle	Use 8A Nozzle	Use 10A Nozzle			Use 17A Nozzle
F						Use 17A Nozzle

PRO-SPRAY® FIXED ARC NOZZLES PERFORMANCE DATA

● **Nozzle 5 Blue**
5 ft. radius
Fixed: ¼, ½, Full
Trajectory: 0°

● **Nozzle 8 Brown**
8 ft. radius
Fixed: ¼, ½, Full
Trajectory: 0°

● **Nozzle 10 Red**
10 ft. radius
Fixed: ¼, ½, Full
Trajectory: 15°

Arc	Position	Pressure (PSI)	Nozzle 5 Blue				Nozzle 8 Brown				Nozzle 10 Red			
			Radius (FT.)	Flow (GPM)	Precip in/hr ■	Precip in/hr ▲	Radius (FT.)	Flow (GPM)	Precip in/hr ■	Precip in/hr ▲	Radius (FT.)	Flow (GPM)	Precip in/hr ■	Precip in/hr ▲
90° 	Q	20	4	0.09	2.25	2.60	7	0.20	1.54	1.78	9	0.34	1.63	1.88
		25	4	0.11	2.54	2.94	8	0.22	1.33	1.53	10	0.39	1.48	1.71
		30	5	0.12	1.80	2.08	8	0.24	1.46	1.69	10	0.42	1.63	1.89
		35	6	0.13	1.36	1.57	9	0.26	1.25	1.45	11	0.46	1.47	1.69
		40	6	0.14	1.46	1.69	9	0.28	1.34	1.55	11	0.49	1.57	1.82
120° 	T	20	Use Hunter 4A Nozzle				7	0.26	1.54	1.78	9	0.46	1.63	1.88
		25					8	0.29	1.33	1.53	10	0.51	1.48	1.71
		30					8	0.32	1.46	1.69	10	0.57	1.63	1.89
		35					9	0.35	1.25	1.45	11	0.61	1.47	1.69
		40					9	0.38	1.34	1.55	11	0.66	1.57	1.82
180° 	H	20	4	0.19	2.25	2.60	7	0.38	1.49	1.72	9	0.70	1.67	1.92
		25	4	0.21	2.54	2.94	8	0.43	1.28	1.48	10	0.79	1.53	1.76
		30	5	0.23	1.80	2.08	8	0.47	1.41	1.63	10	0.88	1.69	1.95
		35	6	0.25	1.36	1.57	9	0.51	1.21	1.39	11	0.95	1.52	1.75
		40	6	0.27	1.46	1.69	9	0.54	1.29	1.49	11	1.03	1.63	1.89
240° 	TT	20	Use Hunter 4A Nozzle				Use Hunter 8A Nozzle				Use Hunter 10A Nozzle			
		25												
		30												
		35												
		40												
270° 	TQ	20	Use Hunter 4A Nozzle				Use Hunter 8A Nozzle				Use Hunter 10A Nozzle			
		25												
		30												
		35												
		40												
360° 	F	20	4	0.37	2.25	2.60	7	0.78	1.54	1.78	9	1.29	1.53	1.77
		25	4	0.42	2.54	2.94	8	0.88	1.33	1.53	10	1.45	1.39	1.61
		30	5	0.47	1.80	2.08	8	0.97	1.46	1.69	10	1.59	1.53	1.76
		35	6	0.51	1.36	1.57	9	1.05	1.25	1.45	11	1.72	1.37	1.58
		40	6	0.55	1.46	1.69	9	1.13	1.34	1.55	11	1.84	1.46	1.69

Bold = Recommended pressure







NOZZLES

PRO-SPRAY® FIXED ARC NOZZLES PERFORMANCE DATA

● **Nozzle 12 Green**
12 ft. radius
Fixed: ¼, ½, ¾, Full
Trajectory: 28°

● **Nozzle 15 Black**
15 ft. radius
Fixed: ¼, ½, ¾, Full
Trajectory: 28°

● **Nozzle 17 Gray**
17 ft. radius
Fixed: ¼, ½
Trajectory: 28°

Arc	Position	Pressure (PSI)	Nozzle 12 Green			Nozzle 15 Black			Nozzle 17 Gray					
			Radius (FT.)	Flow (GPM)	Precip in/hr	Radius (FT.)	Flow (GPM)	Precip in/hr	Radius (FT.)	Flow (GPM)	Precip in/hr			
90° 	Q	20	11	0.54	1.71	1.98	14	0.78	1.53	1.77	16	0.93	1.4	1.61
		25	12	0.61	1.62	1.87	15	0.88	1.51	1.74	17	1.05	1.39	1.61
		30	12	0.67	1.78	2.06	15	0.97	1.67	1.92	17	1.15	1.54	1.77
		35	13	0.72	1.65	1.90	16	1.06	1.59	1.84	18	1.25	1.49	1.72
		40	13	0.78	1.77	2.04	17	1.14	1.52	1.75	19	1.34	1.43	1.65
120° 	T	20	11	0.72	1.71	1.98	14	1.04	1.53	1.77	Use Hunter 17A Nozzle			
		25	12	0.81	1.62	1.87	15	1.17	1.51	1.74				
		30	12	0.89	1.78	2.06	15	1.30	1.67	1.92				
		35	13	0.97	1.65	1.90	16	1.41	1.59	1.84				
		40	13	1.04	1.77	2.04	17	1.52	1.52	1.75				
180° 	H	20	11	1.05	1.67	1.93	14	1.51	1.48	1.71	16	1.91	1.43	1.66
		25	12	1.18	1.58	1.83	15	1.69	1.45	1.67	17	2.15	1.43	1.65
		30	12	1.30	1.74	2.01	15	1.86	1.59	1.84	17	2.37	1.58	1.82
		35	13	1.42	1.61	1.86	16	2.02	1.52	1.75	18	2.57	1.53	1.76
		40	13	1.52	1.73	2.00	17	2.16	1.44	1.66	19	2.76	1.47	1.7
240° 	TT	20	11	1.40	1.67	1.93	14	2.01	1.48	1.71	Use Hunter 17A Nozzle			
		25	12	1.58	1.58	1.83	15	2.26	1.45	1.67				
		30	12	1.74	1.74	2.01	15	2.48	1.59	1.84				
		35	13	1.89	1.61	1.86	16	2.69	1.52	1.75				
		40	13	2.03	1.73	2.00	17	2.88	1.44	1.66				
270° 	TQ	20	11	1.61	1.67	1.93	14	2.34	1.48	1.71	Use Hunter 17A Nozzle			
		25	12	1.82	1.58	1.83	15	2.64	1.45	1.67				
		30	12	2.00	1.74	2.01	15	2.92	1.59	1.84				
		35	13	2.17	1.61	1.86	16	3.18	1.52	1.75				
		40	13	2.33	1.73	2.00	17	3.42	1.44	1.66				
360° 	F	20	11	2.17	1.72	1.99	14	3.04	1.49	1.72	Use Hunter 17A Nozzle			
		25	12	2.45	1.63	1.89	15	3.41	1.46	1.69				
		30	12	2.70	1.80	2.08	15	3.75	1.61	1.85				
		35	13	2.93	1.67	1.93	16	4.07	1.53	1.76				
		40	13	3.15	1.80	2.07	17	4.36	1.45	1.68				

Bold = Recommended pressure

SHORT RADIUS NOZZLES

FEATURES

- Precision engineered for controlled irrigation of close-in spaces
- Available in three different radius versions for total coverage assurance
- Built to last in harsh conditions
- Available in 2, 4, and 6 ft. radius versions



2Q



2H



4Q



4H



6Q



6H

SHORT RADIUS NOZZLES PERFORMANCE DATA







Arc	Pressure (PSI)	Position	● Nozzle Lt. Brown			● Nozzle Lt. Green			● Nozzle Lt. Blue							
			Radius (FT.)	Flow (GPM)	Precip in/hr ■ ▲	Position	Radius (FT.)	Flow (GPM)	Precip in/hr ■ ▲	Position	Radius (FT.)	Flow (GPM)	Precip in/hr ■ ▲			
90° ■	20	2Q	2	0.09	8.66	10.0	4Q	4	0.20	4.81	5.56	6Q	6	0.47	5.03	5.80
	25		2	0.10	9.63	11.11		4	0.22	5.29	6.11		6	0.49	5.24	6.05
	30		2	0.11	10.59	12.23		4	0.22	5.29	6.11		6	0.51	5.45	6.30
	35		2	0.12	11.55	13.34		4	0.24	5.78	6.67		6	0.52	5.56	6.42
	40		2	0.14	13.48	15.56		4	0.24	5.78	6.67		6	0.52	5.56	6.42
180° ■	20	2H	2	0.12	5.78	6.67	4H	4	0.41	4.93	5.70	6H	6	0.95	5.08	5.87
	25		2	0.14	6.74	7.78		4	0.43	5.17	5.97		6	0.97	5.19	5.99
	30		2	0.16	7.70	8.89		4	0.44	5.29	6.11		6	0.98	5.24	6.05
	35		2	0.18	8.66	10.0		4	0.46	5.53	6.39		6	0.99	5.29	6.11
	40		2	0.18	8.66	10.0		4	0.46	5.53	6.39		6	1.00	5.35	6.17

NOZZLES

STRIP PATTERN NOZZLES

FEATURES

- Precision engineered for accurate coverage of tight spaces
- Available in an array of models built to strategically water specific angles
- Built to last in harsh conditions

STRIP PATTERN NOZZLE PERFORMANCE DATA			
Arc	Pressure (PSI)	Width x Length	Flow (GPM)
LCS-515 	20	4 X 14	0.55
	25	5 X 15	0.60
	30	5 X 15	0.65
	35	5 X 15	0.70
	40	5 X 15	0.75
RCS-515 	20	4 X 14	0.55
	25	5 X 15	0.60
	30	5 X 15	0.65
	35	5 X 15	0.70
SS-530 	20	4 X 28	1.10
	25	5 X 30	1.20
	30	5 X 30	1.30
	35	5 X 30	1.40
	40	5 X 30	1.50
ES-515 	20	4 X 14	0.55
	25	5 X 15	0.60
	30	5 X 15	0.65
	35	5 X 15	0.70
CS-530 	20	4 X 28	1.10
	25	5 X 30	1.20
	30	5 X 30	1.30
	35	5 X 30	1.40
SS-918 	20	8 X 17	1.45
	25	9 X 18	1.58
	30	9 X 18	1.72
	35	9 X 18	1.88
	40	9 X 18	2.08

Bold = Recommended pressure



Left Corner Strip
Rectangle: 5' x 15'



Right Corner Strip
Rectangle: 5' x 15'



Side Strip
Rectangle: 5' x 30'



Side Strip
Rectangle: 9' x 18'



Center Strip
Rectangle: 5' x 30'



End Strip
Rectangle: 5' x 15'

STREAM NOZZLES

FEATURES

- These adjustable arc models handle stream sprays with ease
- They offer sprays that at 30 PSI can water as far as 8 or 16 ft., making them a great choice for slopes, ground cover and shrubbery applications



S-8A
7' to 9'





S-16A
15' to 18'

S-8A





NOZZLES

MODEL S-8A STREAM SPRAY NOZZLE PERFORMANCE CHART

Arc S-8A	Pressure (PSI)	Radius (FT.)	Flow (GPM)	Precip in/hr	
				■	▲
90° 	20	7	0.29	2.28	2.63
	25	8	0.32	1.93	2.22
	30	8	0.38	2.11	2.43
	35	8	0.41	2.29	2.64
	40	9	0.54	1.95	2.25
180° 	20	7	0.54	2.12	2.45
	25	8	0.57	1.71	1.98
	30	8	0.60	1.80	2.08
	35	8	0.63	1.89	2.19
	40	9	0.66	1.57	1.81
360 	20	7	1.08	2.12	2.45
	25	8	1.11	1.67	1.93
	30	8	1.15	1.73	2.00
	35	8	1.18	1.77	2.05
	40	9	1.22	1.45	1.67

Bold = Recommended pressure

MODEL S-16A STREAM SPRAY NOZZLE PERFORMANCE CHART

Arc S-16A Blue	Pressure (PSI)	Radius (FT.)	Flow (GPM)	Precip in/hr	
				■	▲
90° 	20	15	0.40	0.68	0.79
	25	16	0.46	0.69	0.80
	30	16	0.50	0.75	0.87
	35	17	0.54	0.72	0.83
	40	18	0.57	0.68	0.78
180° 	20	15	0.67	0.57	0.66
	25	16	0.80	0.60	0.69
	30	16	0.88	0.66	0.76
	35	17	0.97	0.65	0.75
	40	18	1.04	0.62	0.71
360 	20	15	1.19	0.51	0.59
	25	16	1.46	0.55	0.63
	30	16	1.66	0.62	0.72
	35	17	1.82	0.61	0.70
	40	18	1.99	0.59	0.68









Bold = Recommended pressure

BUBBLER NOZZLES

FEATURES

- Hunter bubblers keep the output of water constant regardless of pressure, for precise, easy application
- MSBN and PCN models feature nozzle thread for use with spray heads
- Every plant, shrub, and tree receives the right amount of water with no excess runoff or waste

MULTI-STREAM BUBBLER PERFORMANCE DATA

Arc	Model	Flow (GPM)	Radius (FT.)
	 MSBN-25Q	0.25	1.0
	 MSBN-50Q	0.50	1.5
	 MSBN-50H	0.50	1.0
	 MSBN-10H	1.00	1.5
	 MSBN-10F	1.00	1.0
	 MSBN-20F	2.00	1.5

Notes:

Typical spacing 1 to 3 ft. Flows shown for pressures between 15 and 70 PSI.

Multi-Stream Bubbler



PCN PERFORMANCE DATA

	Model	Flow (GPM)	Pattern Type
	25	0.25	Trickle
	50	0.50	Trickle
	10	1.00	Umbrella
	20	2.00	Umbrella

Notes:

Typical spacing 2 to 4 ft. Flows shown for pressures between 15 and 70 PSI.

PCN



Multi-Stream Bubbler Nozzles



Q
Flow: 0.25 GPM



Q/H
Flow: 0.50 GPM



H/F
Flow: 1.0 GPM



F
Flow: 2.0 GPM

PCN Bubbler Nozzles



Q
Flow: 0.25 GPM



Q/H
Flow: 0.50 GPM



H/F
Flow: 1.0 GPM



F
Flow: 2.0 GPM

BUBBLERS

FEATURES

- Hunter bubblers keep the output of water constant regardless of pressure, for precise, easy application
- ½" female inlet
- Every plant, shrub, and tree receives the right amount of water with no excess runoff or waste

NOZZLES

PCB PERFORMANCE DATA

	Model	Flow (GPM)	Pattern Type
	25	0.25	Trickle
	50	0.50	Trickle
	10	1.00	Umbrella
	20	2.00	Umbrella

Notes:

Typical spacing 2 to 4 ft. Flows shown for pressures between 15 and 70 PSI.

PCB



Pressure Compensating Bubblers



PCB



PCB-R

AFB PERFORMANCE DATA

	Model	Flow (GPM)	Pattern Type
	AFB	< 2.0	Trickle/ Umbrella

AFB



Adjustable Flood Bubbler



AFB

5-CST-B BUBBLER NOZZLE PERFORMANCE DATA

	Pressure (PSI)	Radius (FT.)	Flow (GPM)
	20	5	0.30
	25	5	0.32
	30	5	0.38
	35	5	0.40
	40	5	0.42

5-CST-B



Dual-Stream Bubbler Nozzle



5-CST-B

MP ROTATOR



MP ROTATOR

MP ROTATOR®

Application: **Residential/Commercial**
 Radius: **8' to 35'**

FEATURES

- True matched precipitation at any arc or radius setting
- Radius can be reduced up to 25% on all models
- Color-coded for easy identification
- Double-pop feature keeps dirt and debris out of nozzle
- Removable filter screen prevents large objects from clogging nozzle
- Low precipitation rate
- Wind-resistant multi-stream technology
- Adjustable arc and radius

OPERATING SPECIFICATIONS

- Recommended operating pressure: 40 PSI

OPTIONS

- Specify Pro-Spray PRS40 pop-up for accurate pressure regulation at 40 PSI
- Adding "HT" will specify male threaded nozzles

MP1000-8' to 15' radius



MP1000090
90° to 210°



MP10000210
210° to 270°



MP1000360
360°

MP2000-13' to 21' radius



MP2000090
90° to 210°



MP2000210
210° to 270°



MP2000360
360°

MP ROTATOR - SPECIFICATION BUILDER: ORDER 1 + 2

1 Models	2 Options
MP1000-90 = 8' to 15' radius, adjustable from 90° to 210°	(blank) = No option HT = Male thread version (Not available in 3500)
MP1000-210 = 8' to 15' radius, adjustable from 210° to 270°	
MP1000-360 = 8' to 15' radius, 360°	
MP2000-90 = 13' to 21' radius, adjustable from 90° to 210°	
MP2000-210 = 13' to 21' radius, adjustable from 210° to 270°	
MP2000-360 = 13' to 21' radius, 360°	
MP3000-90 = 22' to 30' radius, adjustable from 90° to 210°	
MP3000-210 = 22' to 30' radius, adjustable from 210° to 270°	
MP3000-360 = 22' to 30' radius, 360°	
MP3500-90 = 33' to 35' radius, adjustable from 90° to 210°	
MPLCS515 = Left corner strip, 5' x 15'	
MPRCS515 = Right corner strip, 5' x 15'	
MPSS530 = Side strip, 5' x 15'	
MPCORNER = 8' to 15' radius, adjustable from 45° to 105°	

Examples:

MP1000-210 = 8' to 15' radius, adjustable from 210° to 270°
 PROS-06 - PRS40-CV - MP2000-90 = 6" pop-up regulated at 40 PSI, drain check valve, with MP 2000 90-210

MP ROTATOR PERFORMANCE DATA

- **MP Corner**
Radius: 8' to 15'
Adjustable Arc
Color Code: Turquoise

	Pressure (PSI)	Radius (FT.)	Flow (GPM)	Flow (GPH)
45°	25	--	--	--
	30	12	0.17	10.2
	35	13	0.18	10.8
	40	14	0.19	11.4
	45	14	0.21	12.6
	50	14	0.22	13.2
	55	15	0.23	13.8
90°	25	11	0.31	18.6
	30	12	0.34	20.4
	35	13	0.36	21.6
	40	14	0.39	23.4
	45	14	0.41	24.6
	50	15	0.43	25.8
	55	15	0.46	27.6
105°	25	11	0.36	21.6
	30	12	0.39	23.4
	35	13	0.42	25.2
	40	14	0.45	27
	45	14	0.48	28.8
	50	15	0.51	30.6
	55	15	0.53	31.8

Bold = Recommended Pressure

MP ROTATOR PERFORMANCE DATA

- **MPLCS515**: Ivory, MP Left Strip
- **MPRCS515**: Copper, MP Right Strip
- **MPSS530**: Brown, MP Side Strip

	Pressure (PSI)	Radius (FT.)	Flow (GPM)	Flow (GPH)
MP Left Strip	30	4 x 14	0.19	11.4
	35	5 x 15	0.21	12.6
	40	5 x 15	0.22	13.2
	45	5 x 15	0.23	13.8
	50	6 x 16	0.25	15.0
	55	6 x 16	0.26	15.6
MP Right Strip	30	4 x 14	0.19	11.4
	35	5 x 15	0.21	12.6
	40	5 x 15	0.22	13.2
	45	5 x 15	0.23	13.8
	50	6 x 16	0.25	15.0
	55	6 x 16	0.26	15.6
MP Side Strip	30	4 x 28	0.38	22.8
	35	5 x 30	0.41	24.6
	40	5 x 30	0.44	26.4
	45	5 x 30	0.47	28.2
	50	6 x 32	0.49	29.4
	55	6 x 32	0.51	30.6

Bold = Recommended Pressure

Notes:

Strip pattern radius can be adjusted by 25%. MP Rotator is designed to maintain matched precipitation after radius adjustment.

MP3000-22' to 30' radius



MP3000090
90° to 210°



MP3000210
210° to 270°



MP3000360
360°

MP3500-33' to 35' radius



MP3500
90° to 210°

MP Strips



MPLCS515
Left Corner
5' x 15'



MPRCS515
Right Corner
5' x 15'



MPSS530
Side Strip
5' x 30'

Male Threaded



MPCORNER
Corner
8' to 15'



MP-HT
Male threaded.

MP Accessories



MP Tool
Adjustments to MP Rotators are simply a snap with this handy tool.



MP Stick
The MP Stick snaps on to 1" PVC of any length to easily adjust MP Rotators while standing up.

MP ROTATOR PERFORMANCE DATA

MP1000

Radius: 8' to 15'
Adjustable Arc and Full Circle
● Maroon: 90° to 210°
● Lt. Blue: 210° to 270°
● Olive: 360°

MP2000

Radius: 13' to 21'
Adjustable Arc and Full Circle
● Black: 90° to 210°
● Green: 210° to 270°
● Red: 360°

MP3000

Radius: 22' to 30'
Adjustable Arc and Full Circle
● Blue: 90° to 210°
● Yellow: 210° to 270°
● Gray: 360°

	Pressure (PSI)	Radius (FT.)	Flow (GPM)	Flow (GPH)	Precip in/hr ■ ▲	Radius (FT.)	Flow (GPM)	Flow (GPH)	Precip in/hr ■ ▲	Radius (FT.)	Flow (GPM)	Flow (GPH)	Precip in/hr ■ ▲			
90° ■	25	--	--	--	--	17	0.31	18.6	0.41	0.48	25	0.69	41.4	0.43	0.49	
	30	12	0.16	9.6	0.43	0.50	18	0.33	19.8	0.39	0.45	27	0.74	44.4	0.39	0.45
	35	13	0.18	10.8	0.40	0.46	19	0.37	22.2	0.39	0.46	28	0.80	48	0.39	0.45
	40	14	0.19	11.4	0.39	0.45	20	0.40	24	0.39	0.44	30	0.86	51.6	0.37	0.43
	45	14	0.20	12.0	0.39	0.45	21	0.42	25.2	0.37	0.42	30	0.91	54.6	0.39	0.45
	50	14	0.21	12.6	0.38	0.43	21	0.44	26.4	0.35	0.40	30	0.96	57.6	0.41	0.47
180° ■	25	--	--	--	--	16	0.58	34.8	0.44	0.50	25	1.44	86.4	0.44	0.51	
	30	12	0.32	19.2	0.43	0.50	17	0.63	37.8	0.42	0.49	27	1.58	94.8	0.42	0.48
	35	13	0.35	21.0	0.40	0.46	18	0.69	41.4	0.41	0.47	28	1.70	102	0.42	0.48
	40	14	0.37	22.2	0.39	0.45	19	0.74	44.4	0.39	0.45	30	1.82	109.2	0.39	0.45
	45	14	0.40	24.0	0.39	0.45	20	0.78	46.8	0.38	0.43	30	1.93	115.8	0.41	0.48
	50	14	0.41	24.6	0.38	0.43	21	0.83	49.8	0.36	0.41	30	2.04	122.4	0.44	0.50
210° ■	25	--	--	--	--	16	0.68	40.8	0.44	0.50	25	1.68	100.8	0.44	0.51	
	30	12	0.37	22.2	0.43	0.50	17	0.74	44.4	0.42	0.49	27	1.84	110.4	0.42	0.48
	35	13	0.41	24.6	0.40	0.46	18	0.80	48	0.41	0.47	28	1.99	119.4	0.42	0.48
	40	14	0.43	25.8	0.39	0.45	19	0.86	51.6	0.39	0.45	30	2.12	127.2	0.39	0.45
	45	14	0.46	27.6	0.39	0.45	20	0.91	55.2	0.38	0.43	30	2.25	135	0.41	0.48
	50	14	0.48	28.8	0.38	0.43	21	0.97	58.2	0.36	0.41	30	2.37	142.2	0.43	0.50
270° ■	25	--	--	--	--	16	0.87	52.2	0.44	0.50	25	2.19	131.4	0.45	0.52	
	30	12	0.48	29	0.43	0.50	17	0.95	57	0.42	0.49	27	2.37	142.2	0.42	0.48
	35	13	0.54	32	0.40	0.46	18	1.03	61.8	0.41	0.47	28	2.55	153	0.42	0.48
	40	14	0.57	34	0.39	0.45	19	1.10	66	0.39	0.45	30	2.73	163.8	0.39	0.45
	45	14	0.60	36	0.39	0.45	20	1.17	70.2	0.38	0.43	30	2.89	173.4	0.41	0.48
	50	14	0.63	38	0.38	0.43	21	1.23	73.8	0.36	0.41	30	3.06	183.6	0.44	0.50
360° ●	25	--	--	--	--	16	1.16	69.6	0.44	0.50	25	2.88	172.8	0.44	0.51	
	30	12	0.65	39	0.43	0.5	17	1.27	76.2	0.42	0.49	27	3.15	189	0.42	0.48
	35	13	0.71	42.6	0.40	0.47	18	1.37	82.2	0.41	0.47	28	3.40	204	0.42	0.48
	40	14	0.75	45	0.39	0.46	19	1.47	88.2	0.39	0.45	30	3.64	218.4	0.39	0.45
	45	14	0.80	48	0.39	0.45	20	1.56	93.6	0.38	0.43	30	3.86	231.6	0.41	0.48
	50	14	0.84	50.4	0.38	0.44	21	1.64	98.4	0.36	0.41	30	4.07	244.2	0.44	0.50
55	15	0.87	52.2	0.37	0.43	21	1.70	202	0.37	0.43	30	4.27	256.2	0.46	0.53	

Bold = Recommended Pressure

Works best with PRS40



See page 41



MP ROTATOR PERFORMANCE DATA

MP3500

Radius: 33' to 35'

Ajustable Arc

● Light Brown: 90° to 210°

	Pressure (PSI)	Radius (FT.)	Flow (GPM)	Flow (GPH)	Precip in/hr	
					■	▲
90° 	25	33	1.04	62.4	0.37	0.42
	30	34	1.13	67.8	0.38	0.43
	35	34	1.21	72.6	0.40	0.47
	40	35	1.28	76.8	0.40	0.46
	45	35	1.38	82.8	0.43	0.50
	50	35	1.43	85.8	0.45	0.52
	55	35	1.50	90.0	0.47	0.54
180° 	25	33	2.21	132.6	0.39	0.45
	30	34	2.24	134.4	0.37	0.43
	35	34	2.65	159.0	0.44	0.51
	40	35	2.86	171.6	0.45	0.52
	45	35	3.10	186.0	0.49	0.56
	50	35	3.21	192.6	0.50	0.58
	55	35	3.28	196.8	0.52	0.60
210° 	25	33	2.59	155.4	0.39	0.45
	30	34	2.84	170.4	0.41	0.47
	35	34	3.08	184.8	0.44	0.51
	40	35	3.29	197.4	0.44	0.51
	45	35	3.54	212.4	0.48	0.55
	50	35	3.76	225.6	0.51	0.59
	55	35	3.94	236.4	0.53	0.61

Bold = Recommended Pressure

VALVES



VALVES

Comparison Chart

	SRV	PGV JAR TOP	PGV	ICV	ICV FILTER SENTRY™	IBV	IBV FILTER SENTRY™	DRIP ZONE CONTROL KIT*
APPLICATIONS								
Potable water	•	•	•	•	•	•	•	•
Reclaimed water				•	•	•	•	•
Secondary water					•		•	•
Pressure regulation	•	•	•	•	•	•	•	•
Flow control	•	•	•	•	•	•	•	•
Angle option			•	•				
High pressure systems				•	•	•	•	
Low pressure systems	•	•	•	•	•	•	•	•
Residential	•	•	•					•
Commercial			•	•	•	•	•	•

* See Drip Zone Control Kits on page 111



ADVANCED FEATURES

Flow Control

Maximize efficiency and prolong the life of a system by fine tuning flow and pressure for each zone.

PGV, PGV-JT, PGV-ASV, ICV, IBV



Reclaimed Water Identification

Violet tags and handles are an option for a clear, quick, and simple method of identification the use of non-potable water.

PGV, PGV-JT, PGV-ASV, ICV, IBV (tag)



Filter Sentry™

The Filter Sentry disk scours the filter clean twice during each valve cycle. Since it is attached to the diaphragm, the Filter Sentry feature can be easily added after a valve has been installed.

ICV, IBV



Accu-Sync™ Capable

Avoid sprinkler over-pressure conditions and experience significant water savings with Hunter's Accu-Sync pressure regulator.

SRV, PGV, PGV-JT, PGV-ASV, ICV, IBV



SRV

Application: **Residential**

Size: **1"**

Flow Rate: **1 to 30 GPM**

FEATURES

- Application: Residential
- Size: 1"
- Double-beaded diaphragm seal design for superior leak-free performance
- Compatible with Hunter’s DC Latching solenoids for use with battery operated controllers
- Captive bonnet bolts provide hassle-free valve maintenance
- Low flow capability allows use of Hunter’s micro-irrigation products
- Encapsulated 24 VAC solenoid with captive plunger for hassle-free service
- Temperature rating: 125° F
- Warranty period: 2 years
- ▶ Accu-Sync™ capable

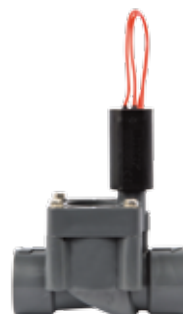

SRV-100G
Inlet Diameter: 1"
5" H x 4½" L x 2½" W

OPERATING SPECIFICATIONS

- Flow rate: 1 to 30 GPM
- Recommended pressure range: 20 to 150 PSI

▶ = Advanced Feature descriptions on page 61

SRV - SPECIFICATION BUILDER: ORDER 1 + 2 + 3		
1 Model	2 Inlet/Outlet	3 Options (User Installed)
SRV-100G = no flow control	(blank) = Female NPT S = slip x slip B = BSP threads	(blank) = No option DC = DC latching solenoid CC = Solenoid conduit cover AS-ADJ = Accu-Sync adjustable pressure regulator AS-xx* = Accu-Sync pressure regulator 20* = 20 PSI, 30* = 30 PSI, 40* = 40 PSI, 50* = 50 PSI, 70* = 70 PSI

SRV PRESSURE LOSS IN PSI	
Flow (GPM)	1" globe
1	1.1
5	1.9
10	1.9
15	1.6
20	3.3
25	5.0
30	6.1

Examples:

SRV-100G - DC = 1" Globe valve, no flow control, w/ DC latching solenoid

SRV-100G - S = 1" Globe valve, no flow control, slip x slip

PGV

Application: **Residential/Light Commercial**

Size: **1", 1½", 2"**

Flow Rate: **0.2 to 150 GPM**

FEATURES

- Application (PGV100): Residential
- Application (PGV101, 151, 201): Residential/Light commercial
- Sizes: 1", 1½", 2"
- External and internal manual bleed allows quick and easy "at the valve" activation
- Double-beaded diaphragm seal design for superior leak-free performance
- DC latching solenoids enable Hunter's battery-powered controllers
- Captive bonnet bolts provide hassle-free valve maintenance
- Low flow capability allows use of Hunter's micro-irrigation products
- Encapsulated 24 VAC solenoid with captive plunger for hassle-free service
- Temperature rating: 150° F
- Warranty period: 2 years
- ▶ Flow control
- ▶ Reclaimed water ID handle
- ▶ Accu-Sync™ capable



PGV-100G
Inlet Diameter: 1"
5" H x 4½" L x 2½" W



PGV-201
Inlet Diameter: 2"
8" H x 6¾" L x 5¼" W

OPERATING SPECIFICATIONS

- Flow rate
 - PGV 100: 0.2 to 30 GPM
 - PGV 101: 0.2 to 30 GPM
 - PGV 151: 20 to 120 GPM
 - PGV 201: 20 to 150 GPM
- Recommended pressure range: 20 to 150 PSI

SOLENOID SPECIFICATION

- 24 VAC solenoid
 - 350 mA inrush, 190 mA holding, 60 Hz (North America)
 - 370 mA inrush, 210 mA holding, 50 Hz (most International locations)

▶ = Advanced Feature descriptions on page 61

PGV PRESSURE LOSS IN PSI

Flow (GPM)	1" globe	1" angle	1½" globe	1½" angle	2" globe	2" angle
1	1.1	1				
5	1.9	1				
10	1.9	1				
15	1.6	1				
20	3.3	2	3.0	3.0	1	1
30	6.1	3	3.0	3.0	1	2
40			3.0	3.0	2	2
50			4.0	3.5	1	1
60			5.0	4.0	2	2
80			5.5	4.5	3	2
100			9.0	8.0	5	3
120			11.5	10.5	6	5
135					8	7
150					10	9

PGV - SPECIFICATION BUILDER: ORDER 1 + 2 + 3 + 4

1 Model	2 Inlet/Outlet	3 Options (Factory Installed)	4 Options (User Installed)
PGV-100G = 1" Globe valve, no flow control PGV-101G = 1" Globe valve, w/ flow control PGV-100A = 1" Angle valve, no flow control PGV-101A = 1" Angle valve, w/ flow control PGV-151 = 1½" Globe/angle valve, w/ flow control PGV-201 = 2" Globe/angle valve, w/ flow control	(blank) = Female NPT S = slip x slip (Excludes PGV-151 and PGV-201) B = BSP threads	(blank) = No Option DC = DC latching solenoid LS = Valve w/o solenoid	(blank) = No option R = Reclaimed water ID handle (Except for PGV-100) DC = DC latching solenoid CC = Solenoid conduit cover AS-ADJ = Accu-Sync adjustable pressure regulator AS-xx* = Accu-Sync pressure regulator xx* Choose Accu-Sync pressure regulator: 20 = 20 PSI, 30 = 30 PSI, 40 = 40 PSI, 50 = 50 PSI, 70 = 70 PSI
PGV-100 = 1" Globe valve, no flow control PGV-101 = 1" Globe valve, w/ flow control	MB = Male NPT x 1" Barb MB125 = Male NPT x 1¼" barb MM = Male x male (NPT) MMB = Male x male (BSP)		

Examples:

- PGV-101G - S - DC = 1" Globe valve, with flow control, slip x slip, and DC latching solenoid
- PGV-100 - MB - AS-ADJ = 1" Globe valve, no flow control, male thread x 1" barb, and Accu-Sync™ adjustable pressure regulator
- PGV-151 - DC - R = 1½" Globe/angle valve, with flow control, DC latching solenoid, and reclaimed water ID handle

PGV JAR TOP

Application: **Residential**
 Size: **1"**
 Flow Rate: **0.2 to 30 GPM**

FEATURES

- Application: Residential
- Size: 1"
- External and internal manual bleed allows quick and easy "at the valve" activation
- Durable glass-filled nylon threaded bonnet ring allows easy access without tools
- Double-beaded diaphragm seal design for superior leak-free performance
- DC latching solenoids enable Hunter's battery-powered controllers
- Low flow capability allows use of Hunter's micro irrigation products
- Encapsulated 24 VAC solenoid with captive plunger for hassle-free service
- Temperature rating: 150° F
- Warranty period: 2 years
- ▶ Flow control
- ▶ Reclaimed water ID handle
- ▶ Accu-Sync™ capable

OPERATING SPECIFICATIONS

- Flow rate: 0.2 to 30 GPM
- Recommended pressure range: 20 to 150 PSI

SOLENOID SPECIFICATION

- 24 VAC solenoid
 - 350 mA inrush, 190 mA holding, 60 Hz (North America)
 - 370 mA inrush, 210 mA holding, 50 Hz (most International locations)

▶ = Advanced Feature descriptions on page 61



PGV-100JT - G
 Inlet Diameter: 1"
 5½" H x 4½" L x 3¼" W



PGV-101JT - G
 Inlet Diameter: 1"
 5½" H x 4½" L x 3¼" W

VALVES

PGV JAR-TOP - SPECIFICATION BUILDER: ORDER 1 + 2 + 3 + 4				PGV JAR TOP PRESSURE LOSS IN PSI	
1 Model	2 Inlet/Outlet	3 Options (Factory Installed)	4 Options (User Installed)	Flow (GPM)	1" globe
<p>PGV-100JT = 1" Globe jar-top valve, no flow control</p> <p>PGV-101JT = 1" Globe jar-top valve, w/ flow control</p>	<p>G = Female NPT</p> <p>GS = slip x slip</p> <p>GB = Female BSP</p> <p>MM = Male x male (NPT)</p> <p>MMB = Male x male (BSP)</p> <p>MB = Male NPT x 1" Barb</p> <p>MB075 = Male NPT x ¾" barb</p> <p>MB125 = Male NPT x 1 ¼" barb</p>	<p>(blank) = No option</p> <p>LS = Less solenoid <i>(Only available on 101JT-G, 100JT-G, 101JT-GB, 100JT-GB)</i></p> <p>DC = DC latching solenoid</p>	<p>(blank) = No option</p> <p>R = Reclaimed water ID handle <i>(Except for PGV-100JT)</i></p> <p>CC = Solenoid conduit cover</p> <p>DC = DC latching solenoid</p> <p>AS-ADJ = Accu-Sync adjustable pressure regulator</p> <p>AS-xx* = Accu-Sync pressure regulator 20* = 20 PSI, 30* = 30 PSI, 40* = 40 PSI, 50* = 50 PSI, 70* = 70 PSI</p>	<p>1</p> <p>5</p> <p>10</p> <p>15</p> <p>20</p> <p>30</p> <p>30</p>	<p>1.1</p> <p>1.9</p> <p>1.9</p> <p>1.6</p> <p>3.3</p> <p>6.1</p> <p>6.1</p>

Examples:

- PGV-101JT - G = 1" Globe jar-top valve, with flow control, and female NPT
- PGV-101JT - G - R = 1" Globe jar-top valve, with flow control, slip x slip, and reclaimed water ID handle
- PGV-101JT - G - R = 1" Globe jar-top valve, with flow control, female NPT, and reclaimed water ID handle

PGV-ASV

Application: **Residential**
 Size: **¾", 1"**
 Flow Rate: **0.2 to 30 GPM**

FEATURES

- Application: Residential
- Size: ¾", 1"
- External and internal manual bleed allows quick and easy "at the valve" activation
- Durable six-bolt bonnet design for maximum strength
- Removable anti-siphon cap for simple servicing
- Double-beaded diaphragm seal design for superior leak-free performance
- DC latching solenoids enable Hunter's battery-powered controllers
- Captive bonnet bolts provide hassle-free valve maintenance
- Low flow capability allows use of Hunter's micro irrigation products
- Encapsulated 24 VAC solenoid with captive plunger for hassle-free service
- Temperature rating: 150° F
- Warranty period: 2 years
- ▶ Flow control
- ▶ Reclaimed water ID handle
- ▶ Accu-Sync™ capable

OPERATING SPECIFICATIONS

- Flow rate: 0.2 to 30 GPM
- Recommended pressure range: 20 to 150 PSI

SOLENOID SPECIFICATION

- 24 VAC solenoid
 - 370 mA inrush, 190 mA holding, 60 cycles
 - 475 mA inrush, 190 mA holding, 50 cycles

▶ = Advanced Feature descriptions on page 61



PGV-075-ASV
 Inlet Diameter: ¾"
 5½" H x 5¾" L x 2½" W



PGV-101-ASV
 Inlet Diameter: 1"
 5½" H x 6¼" L x 2½" W

VALVES

PGV-ASV - SPECIFICATION BUILDER: ORDER 1 + 2 + 3 + 4

1 Model	2 Inlet/Outlet	3 Options (Factory Installed)	4 Options (User Installed)
PGV-075 = ¾" Anti-siphon valves w/ flow control PGV-101 = 1" Anti-siphon valves w/ flow control	ASV = Female NPT ASV-S = Slip x slip	LS = Valve w/o solenoid	(blank) = No option R = Reclaimed water ID handle CC = Solenoid conduit cover DC = DC latching solenoid AS-ADJ = Accu-Sync adjustable pressure regulator AS-xx* = Accu-Sync pressure regulator 20* = 20 PSI, 30* = 30 PSI, 40* = 40 PSI, 50* = 50 PSI, 70* = 70 PSI

PGV-ASV PRESSURE LOSS IN PSI		
Flow (GPM)	¾" globe	1" globe
1	1	1
5	2	2
10	2	2
15	3	3
20	6	6
25		6
30		9

Examples:

- PGV-075 - ASV = ¾" Anti-siphon valves with flow control, and female NPT
- PGV-101 - ASV - S - DC = 1" Anti-siphon valves with flow control, slip x slip, and DC latching solenoid
- PGV-101 - ASV - R = 1" Anti-siphon valves with flow control, female NPT, and reclaimed water ID handle

ICV

Application: **Commercial/Municipal**
 Size: **1", 1½", 2", 3"**
 Flow Rate: **0.1 to 300 GPM**

FEATURES

- Application: Commercial/municipal
- Sizes: 1", 1½", 2", 3"
- External and internal manual bleed allows quick and easy "at the valve" activation
- Glass-filled nylon construction results in the highest pressure rating
- Double-beaded diaphragm seal design for superior leak-free performance
- Fabric-reinforced EPDM diaphragm and EPDM seat ensure superior performance in all water conditions
- DC latching solenoids enable Hunter's battery-powered controllers
- Captive bonnet bolts provide hassle-free valve maintenance
- Low flow capability allows for use with Hunter's micro irrigation products
- Encapsulated 24 VAC solenoid with captive plunger for hassle-free service
- Temperature rating: 150° F
- Warranty period: 5 years
- ▶ Flow control
- ▶ Filter Sentry™
- ▶ Reclaimed water ID handle
- ▶ Accu-Sync™ capable

OPERATING SPECIFICATIONS

- Flow rate
 - ICV-101G: 0.1 to 40 GPM
 - ICV-151G: 20 to 135 GPM
 - ICV-201G: 40 to 150 GPM
 - ICV-301: 150 to 300 GPM
- Recommended pressure range: 20 to 220 PSI

SOLENOID SPECIFICATION

- 24 VAC solenoid
 - 370 mA inrush, 190 mA holding, 60 cycles
 - 475 mA inrush, 190 mA holding, 50 cycles

▶ = Advanced Feature descriptions on page 61



ICV-101G
5½" H x 3¾" L x 4" W



ICV-151G
7½" H x 6⅞" L x 5½" W



ICV-201G
7½" H x 6⅞" L x 5½" W



ICV-301
10¾" H x 9¼" L x 7⅞" W

VALVES

ICV PRESSURE LOSS IN PSI

Flow (GPM)	1" globe	1½" globe	2" globe	3" globe	3" angle
0.1	2				
0.5	2				
1	2				
5	2.5				
10	3				
15	3				
20	3	1.5			
30		1.5			
40	7	1.7	0.8		
50		2.2	1.2		
60		3.0	1.7		
75		3.9	2.4		
90		5.5	3.2		
100		7.0	4.2		
120		10.9	6.5		
135		12.7	7.9		
150		16.2	9.8	2.5	1.9
175			13.3	3.0	2.4
200			17.7	4.1	3.3
225				5.3	4.3
250				6.7	5.5
275				8.3	6.9
300				10.1	8.5

ICV - SPECIFICATION BUILDER: ORDER 1 + 2 + 3 + 4

1 Model	2 Inlet/Outlet	3 Options (Factory Installed)	4 Options (User Installed)
ICV-101G = 1" globe valve	(blank) = NPT threads	(blank) = No option	(blank) = No option
ICV-151G = 1½" globe valve	B = BSP threads	FS = Filter Sentry	R = Reclaimed water ID handle
ICV-201G = 2" globe valve		DC = DC latching solenoid	CC = Solenoid conduit cover
ICV-301 = 3" globe/angle valve			DC = DC latching solenoid
			AS-ADJ = Accu-Sync adjustable pressure regulator
			AS-xx* = Accu-Sync pressure regulator 20* = 20 PSI, 30* = 30 PSI, 40* = 40 PSI, 50* = 50 PSI, 70* = 70 PSI

Examples:

ICV-101G = 1" globe valve, NPT threads

ICV-151G - FS - R = 1½" globe valve, NPT threads, Filter Sentry, and reclaimed water ID tag

IBV

Application: **Commercial/Municipal**
 Size: **1", 1½", 2", 3"**
 Flow Rate: **0.1 to 300 GPM**

FEATURES

- Application: Commercial/municipal
- Sizes: 1", 1½", 2", 3"
- External and internal manual bleed allows quick and easy "at the valve" activation
- Double-beaded diaphragm seal design for superior leak-free performance
- Fabric-reinforced EPDM diaphragm and EPDM seat ensure superior performance in all conditions
- DC latching solenoids enable Hunter's battery-powered controllers
- Captive bonnet bolts provide hassle-free valve maintenance
- Low flow capability allows use of Hunter's micro irrigation products
- Encapsulated 24 VAC solenoid with captive plunger for hassle-free service
- Temperature rating: 150° F
- Warranty period: 5 years
- ▶ Flow control
- ▶ Filter Sentry™
- ▶ Accu-Sync™ capable

OPERATING SPECIFICATIONS

- Flow rate
 - IBV-101G: 0.1 to 40 GPM
 - IBV-151G: 20 to 135 GPM
 - IBV-201G: 40 to 150 GPM
 - IBV-301: 150 to 300 GPM
- Recommended pressure range: 20 to 220 PSI

SOLENOID SPECIFICATION

- 24 VAC solenoid
 - 370 mA inrush, 190 mA holding, 60 cycles
 - 475 mA inrush, 190 mA holding, 50 cycles

▶ = Advanced Feature detailed descriptions on page 61

IBV - SPECIFICATION BUILDER: ORDER 1 + 2 + 3 + 4			
1 Model	2 Inlet/Outlet	3 Options (Factory Installed)	4 Options (User Installed)
IBV-101G = 1" globe valve	(blank) = NPT threads	(blank) = No option	(blank) = No option
IBV-151G = 1½" globe valve	B = BSP threads	FS = Filter Sentry	R = Reclaimed water ID tag
IBV-201G = 2" globe valve		DC = DC latching solenoid	CC = Solenoid conduit cover
IBV-301G = 3" globe/angle valve			DC = DC latching solenoid
			AS-ADJ = Accu-Sync adjustable pressure regulator
			AS-xx* = Accu-Sync pressure regulator
			20* = 20 PSI, 30* = 30 PSI,
			40* = 40 PSI, 50* = 50 PSI,
			70* = 70 PSI

Examples:

IBV-101G = 1" globe valve
 IBV-151G - FS - R = 1½" globe valve, NPT threads, Filter Sentry, and reclaimed water ID tag

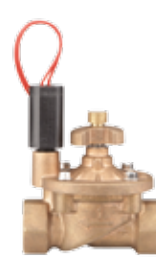

IBV-101G
4½" H x 3¾" L x 5¼" W

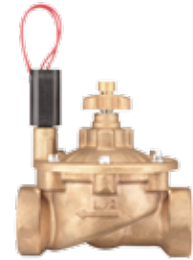

IBV-151G
6¼" H x 5¼" L x 6½" W

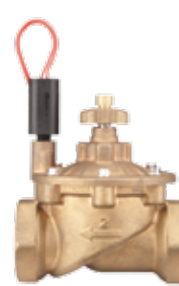

IBV-201G
6½" H x 5¼" L x 6⅞" W



IBV-301G
9½" H x 9⅞" L x 7¼" W

IBV PRESSURE LOSS IN PSI				
Flow (GPM)	1"	1½"	2"	3"
0.1	2			
0.5	2			
1	2			
5	2.5			
10	3			
15	3			
20	3	1.5		
30	4	1.5		
40	7	1.7	0.8	
50		2.2	1.2	
60		3	1.7	
75		3.9	2.4	
90		5.5	3.2	
100		7	4.2	
120		10.9	6.5	
135		12.7	7.9	
150		16.2	9.8	2.5
175			13.3	3
200			17.7	4.1
225				5.3
250				6.7
275				8.3
300				10.1

Notes:

Charts based on full-open flow

ACCU-SYNC™

Application: **Residential/Commercial**
 Type: **Pressure Regulator**

OPERATING SPECIFICATIONS

- Regulation from 20 to 100 PSI
- Static pressure: 150 PSI
- Required dynamic pressure differential: 15 PSI
- Works with AC and DC latching solenoids
- Works with any Hunter valve

ACCU-SYNC VALVE RECOMMENDED FLOW RANGE

Valve	Flow (GPM)
SRV-100/101	5 to 30
PGV-100/101	5 to 30
PGV-151	20 to 120
PGV-201	40 to 150
ICV-101	5 to 40
ICV-151	20 to 150
ICV-201	40 to 200
ICV-301	150 to 300
IBV-101	5 to 40
IBV-151	20 to 150
IBV-201	40 to 200
IBV-301	150 to 300

ACCU-SYNC APPLICATIONS

● Adjustable 20-100 PSI	For full customization, the adjustable Accu-Sync can regulate pressure from 20 to 100 PSI
● Fixed 20 PSI	Ideal for point source micro irrigation systems
● Fixed 30 PSI	Ideal for spray systems
● Fixed 40 PSI	Ideal for Hunter's MP Rotator and large in-line drip systems
● Fixed 50 PSI	Ideal for mid-range rotors
● Fixed 70 PSI	Ideal for larger rotors

Adjustable



AS-ADJ
 Height with solenoid: 3¼"
 Length: 4½"

Fixed



AS-20
 Height with solenoid: 3¼"
 Length: 4½"



AS-30
 Height with solenoid: 3¼"
 Length: 4½"



AS-40
 Height with solenoid: 3¼"
 Length: 4½"



AS-50
 Height with solenoid: 3¼"
 Length: 4½"



AS-70
 Height with solenoid: 3¼"
 Length: 4½"



Installation

The Accu-Sync shown installed on the ICV and PGV valves.

VALVES

QUICK COUPLERS

Application: **Commercial**
 Pressure Rated at: **150 PSI**

FEATURES

- 100% Interchangeable with Rain Bird®, Toro®, and Buckner®
- Red brass and stainless steel construction
- TuffTop™ thermoplastic locking and non-locking covers
- Optional WingThing™ stabilization and Acme key connection
- Stainless steel lug on 1" and 1¼" keys
- Spring-loaded covers with stainless steel springs for positive closing and protection of valve's sealing components

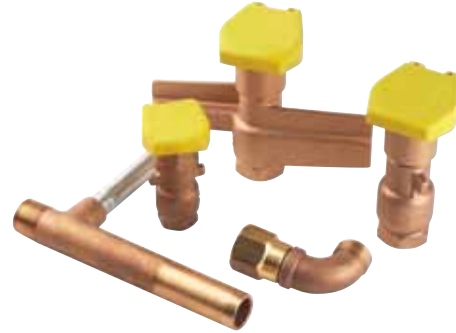

Quick Couplers



Reclaimed Option

All locking models have an optional purple TuffTop™ cover for sites using reclaimed water.

HQ PRESSURE LOSS IN PSI

Flow (GPM)	HQ-3	HQ-33	HQ-44	HQ-5
5	0.8	1		
10	1.8	2		
15	4.1	4.3	2.2	
20	7.2	7.6	4.4	1
30			11.5	3
40				6.3
50				9.2
60				13
70				19.8

QUICK COUPLER, KEY AND HOSE SWIVEL CHARTS

Model	Inlet threads	Slots	Body	Color*	Locking	Key	Swivels
HQ-3RC	¾" NPT	2	1 - Piece	Yellow	No	HK-33	HS-0
HQ-33DRC	¾" NPT	2	2 - Piece	Yellow	No	HK-33	HS-0
HQ-33DLRC	¾" NPT	2	2 - Piece	Yellow	Yes	HK-33	HS-0
HQ-44RC	1" NPT	1	2 - Piece	Yellow	No	HK-44	HS-1 or HS-2
HQ-LRC	1" NPT	1	2 - Piece	Yellow	Yes	HK-44	HS-1 or HS-2
HQ-RC-AW	1" NPT	Acme	2 - Piece Wing**	Yellow	No	HK-44A	HS-1 or HS-2
HQ-44LRC-AW	1" NPT	Acme	2 - Piece Wing**	Yellow	Yes	HK-44A	HS-1 or HS-2
HQ-4RC	1" NPT	2	1 - Piece	Yellow	No	HK-55	HS-1 or HS-2
HQ-5LRC	1" NPT	2	1 - Piece	Yellow	Yes	HK-55	HS-1 or HS-2
HQ-5RC-B	1" BSP	2	1 - Piece	Yellow	No	HK-55	HS-1-B or HS-2-B
HQ-5LRC-B	1" BSP	2	1 - Piece	Yellow	Yes	HK-55	HS-1-B or HS-2-B

Notes:

* All Locking cover models are available with purple covers for reclaimed water applications.

** Anti-rotation stabilization wings.

QUICK COUPLER – SPECIFICATION BUILDER: ORDER 1 + 2 + 3

1 Model	2 Cover Options	3 Additional Options
<p>HQ3 = ¾" Inlet, 1-piece body, 2 slots</p> <p>HQ5 = 1" Inlet, 1-piece body, 2 slots</p> <p>HQ33D = ¾" Inlet, 2-piece body, 2 slots</p> <p>HQ44 = 1" Inlet, 2-piece body, 1 slot or Acme</p>	<p>RC = Yellow rubber cover</p> <p>LRC = Yellow locking rubber cover <i>(Not available for the HQ3 body)</i></p>	<p>(blank) = No option</p> <p>AW = Acme key with anti-rotation wings <i>(Only available in body HQ44)</i></p> <p>BSP = BSP threads <i>(Only available in body HQ5)</i></p> <p>R = Purple locking cover <i>(reclaimed water ID; Only available LRC models)</i></p>

Examples:

- HQ3 - RC = HQ3 valve with rubber cover
- HQ44 - LRC = HQ44 valve with locking rubber cover
- HQ44- LRC - R = HQ44 valve with locking rubber cover and reclaimed water ID
- HQ44 - LRC - AW- R = HQ valve, locking rubber cover, Acme key socket, anti-rotation wings and reclaimed ID
- HQ5 - LRC -BSP = HQ5 valve with locking rubber cover and BSP body inlet threads

KEYS

Key Model	Compatible Valve	Compatible Swivel
HK33 = ¾" valve, ¾" key inlet	HQ3, HQ33	HS0
HK44 = 1" valve, 1" key inlet	HQ44	HS1, HS2, HS1B, HS2B
HK44A = 1" valve, Acme key inlet	HQ44AW	HS1, HS2, HS1B, HS2B
HK55 = 1" valve, 1¼" key inlet	HQ5	HS1, HS2, HS1B, HS2B

HOSE SWIVELS

Hose Swivel	Compatible Key
HS0 = ¾" inlet, ¾" hose outlet	HK33
HS1 = 1" inlet, ¾" hose outlet	HK44, HK44A, HK55
HS2 = 1" inlet, 1" hose outlet	HK44, HK44A, HK55
HS1B = 1" inlet, ¾" BSP outlet	HK44, HK44A, HK55
HS2B = 1" inlet, 1" BSP outlet	HK44, HK44A, HK55

CONTROLLERS



CONTROLLERS

Comparison Chart

	X-CORE	PCC	PRO-C	I-CORE	ACC	XC HYBRID [†]	NODE [†]	WVS [†]
APPLICATIONS								
Residential	•	•	•			•	•	•
Light commercial		•	•			•	•	•
Commercial				•		•	•	
High-end commercial					•	•	•	•
TYPE								
Fixed	•	•				•	•	•
Modular			•	•	•			
Decoder				•	•			
Indoor	•	•	•					
Outdoor	•	•	•	•	•	•	•	•
FEATURES								
Number of stations	2, 4, 6, 8	6, 9, 12, 15	3 to 15	6 to 42* 1 to 48**	12 to 42* 1 to 99**	4, 6, 8, 10, 12	1, 2, 4, 6	1, 2, 4
Independent programs	3	3	3	4	6	3	3	program by station
Start times per program	4	4	4	8 (A, B, C) 16 (D)	10	4	4	9
Max. station run time (hrs)	4	6	6	12	6	4	6	4

[†] Battery-powered controllers

* Conventional controller

** Decoder controller



ADVANCED FEATURES

Automatic Short Circuit Protection

Automatic short circuit protection, found in all Hunter AC powered controllers, automatically detects electrical faults typically caused by wiring issues or damage. Shorted stations are skipped, allowing watering to continue for those stations that are not faulty. There are no fuses to blow or internal circuit breakers to trip that can result in completely disabling irrigation.

X-Core, PCC, Pro-C, I-Core, ACC

Real Time Flow Monitoring

This feature permits the connection of a flow meter to recognize high or low flow conditions and react automatically to alarms. The controller learns typical flows for each zone of irrigation and then monitors performance during automatic irrigation. When incorrect flows are detected, the controller can identify the faulty station and shut it down. This feature is designed for best use with a normally-closed master valve. The alarm parameters are user-programmable for optimal flexibility. Flow totals are also recorded in controller memory to verify system water usage.

I-Core, ACC

Seasonal Adjustment

This feature allows for quick adjustments to irrigation run times through a percentage scale. During peak season, set the seasonal adjust to 100%. If weather conditions require less water, enter the appropriate percentage value (e.g. 50%) to cut down irrigation run times without the need to adjust each station in the program. Hunter offers three different ways to use Seasonal Adjustment to reduce water usage:

Globally: Provides a seasonal adjustment value to all controller programs (available on most Hunter controllers)

Monthly: Allows user to program seasonal adjustment values for each month of the year (available on I-Core controller). The controller will automatically change the programmed seasonal adjustment value at the first day of every month.

I-Core

Daily (Solar Sync ET sensor): Implements an automatic daily adjustment based on measured local weather (available for most Hunter controllers)

X-Core, PCC, Pro-C, I-Core, ACC

CONTROLLERS

Easy Retrieve™

A manual back-up utility that stores a complete controller's schedule and setup information in back-up memory. This allows the saved watering schedule to be restored at any time. This can be used to set a controller back to the initial settings after tampering or at the beginning of a new season.

X-Core, PCC, Pro-C, I-Core, ACC, XC Hybrid, Node

Non-Water Days

Day(s) of the week can be programmed Off in advance, so that irrigation does not occur regardless of program interval schedules. For example, if the gardener mows the lawn on Saturday, the Event Day Off feature allows Saturday to be programmed Off, so that watering will not occur.

PCC, Pro-C, I-Core, ACC

No Water Window

User-specified periods of time during which the controller will not allow automatic irrigation. No Water Window can be used to comply with local watering restrictions or to prevent conflicts with pedestrian traffic. This setting does not affect manual watering options for local maintenance.

I-Core, ACC

Delay Between Stations

A delay in watering between individual stations as the controller steps sequentially through zones of irrigation. The delay may range from a few seconds, to permit slow-closing valves time to shut down, or much longer to allow pressure tanks, etc., to refill or recharge.

X-Core, PCC, Pro-C, I-Core, ACC

Programmable Rain Delay

A user-specified number of days for the controller to remain in Off mode, but then automatically revert to automatic irrigation. This will prevent watering during an extended period of inclement weather, but will resume watering automatically without requiring a return visit to the controller. The controller displays the number of days remaining before watering resumes.

X-Core, PCC, Pro-C, I-Core, ACC, XC Hybrid, Node

Cycle and Soak

Water-saving feature that allows the operator to specify a maximum run time for each single station, followed by a minimum soak time, to prevent runoff from slopes or saturated soil. The operator can enter any run time, and the controller will automatically divide it into cycles to allow the water to be absorbed during the soak periods. The feature is adjustable by individual station for unique soil and site conditions.

I-Core, ACC

Simultaneous Station Groups

The ability to group stations into larger irrigation units that run together within automatic programs. This permits consolidation of large systems into fewer items to program and can be used to control system flow in high capacity installations.

ACC

Quick Check™

This feature allows for the quick diagnosis of wiring problems to valves in the field instead of checking each field wiring circuit for potential problems. Quick Check can detect a field wiring short and displays an "ERR" and station number on the display.

X-Core, PCC, Pro-C, I-Core, ACC

Total Run Time Calculator

This feature adds up all run times, and calculates the total duration of a program or to instantly display the full length of an irrigation cycle. This information can be used to determine the time of day at which watering will end.

PCC, Pro-C, I-Core, X-Core, ACC, Node

Sensor Programmability

The ability to specify which program or stations will be shut down in response to a specific sensor alarm. This allows stations or programs unaffected by the sensor to continue automatic operations.

X-Core, PCC, Pro-C, I-Core, ACC, XC Hybrid

Non-Volatile Memory

This feature offers protection against unreliable power, retaining current time, day, and program data.

Available on all Hunter controllers

X-CORE

Application: **Residential**
 Number of Stations: **2, 4, 6, 8**
 Type: **Fixed**

FEATURES

- Number of stations: 2, 4, 6, 8
- Type: Fixed
- Enclosures: Indoor and outdoor
- Independent programs: 3
- Start times per program: 4
- Max. station run time: 4 hrs
- Warranty period: 2 years
- ▶ Easy Retrieve™ memory
- ▶ Programmable rain delay
- ▶ Quick Check
- ▶ Non-volatile memory
- ▶ Automatic short circuit protection
- ▶ Seasonal adjustment: Global, or automatic updates with Solar Sync™
- ▶ Delay between stations
- ▶ Sensor programmability
- ▶ Total Run Time



Plastic indoor
6½" H x 5¾" W x 2" D



Plastic outdoor
8⅝" H x 7" W x 3¾" D

ELECTRICAL SPECIFICATIONS

- Transformer input: 120 VAC or 230/240 VAC (international model)
- Transformer output (24 VAC): 1 A
- Station output (24 VAC): 0.56 A
- Pump/master valve: (24 VAC): 0.28 A
- Sensor inputs: 1
- Operating temperature: 0° F to 140° F

APPROVALS

- CE, UL, cUL, C-tick, FCC

▶ = Advanced Feature descriptions on pages 73 and 74

X-CORE - SPECIFICATION BUILDER: ORDER 1 + 2 + 3 + 4

1 Models	2 Transformer	3 Indoor/Outdoor	4 Options
XC-2 = 2 stations <i>(indoor model only)</i> XC-4 = 4 stations XC-6 = 6 stations XC-8 = 8 stations	00 = 120/VAC 01 = 230/240 VAC	(blank) = Outdoor model i = Indoor model	(blank) = No option E = 230/240 VAC with European connections A = 230/240 VAC with Australian connections <i>(Australian outdoor models have internal transformer with cord)</i>

Examples:

- XC-200i = 2-Station 120 VAC indoor controller, with plastic cabinet
- XC-400 = 4-Station 120 VAC outdoor controller, with plastic cabinet
- XC-600i = 6-Station 120 VAC indoor controller, with plastic cabinet
- XC-800 = 8-Station 120 VAC outdoor controller, with plastic cabinet

XC HYBRID

Application: **Residential/Commercial**
 Number of Stations: **4, 6, 8, 10, 12**
 Type: **Battery Operated/Fixed**

FEATURES

- Battery or AC powered
- Type: Fixed
- Number of stations: 4, 6, 8, 10, 12 (plastic); 6, 12 (stainless steel)
- Enclosures: Indoor/outdoor plastic; outdoor stainless steel
- Independent programs: 3
- Start times per program: 4
- Max. station run time: 4 hrs
- Operates DC latching solenoids only
- Optional Solar Panel SPXCH provides maintenance free operation
- Warranty period: 2 years
- ▶ Easy Retrieve™ memory
- ▶ One touch manual start and advance
- ▶ Rain sensor bypass
- ▶ Programmable rain delay
- ▶ Non-volatile memory
- ▶ Automatic short circuit protection
- ▶ Global seasonal adjustment
- ▶ Delay between stations
- ▶ Sensor programmability

ELECTRICAL SPECIFICATIONS

- Operates DC latching solenoids (only) 9-11 VDC
- Pump/master valve
- Sensor inputs: 1
- Operating temperature: 0° F to 140° F

POWER SOURCE

- Operates on battery power or 24 VAC plug in transformer or optional Solar Panel
- Plastic model uses 6 AA batteries
- Stainless model uses 6 C batteries

APPROVALS

- CE, UL, cUL, C-tick

▶ = Advanced Feature descriptions on pages 73 and 74



Plastic indoor/outdoor
8⁵/₈" H x 7" W x 3³/₄" D



Stainless steel outdoor
9³/₄" H x 7³/₈" W x 4¹/₄" D



Pole for Stainless Steel Model 4' H



Optional Solar Panel
3¹/₄" H x 3" W x 5⁸/₈" D

MAXIMUM WIRE RUNS	
Wire Size	Max Distance (ft)
18 AWG	500
16 AWG	800
14 AWG	1300
12 AWG	2000

XC HYBRID	
Model	Description
XCH-400	4-Station indoor/outdoor controller
XCH-600	6-Station indoor/outdoor controller
XCH-600-SS	6-Station outdoor controller, stainless steel
XCH-800	8-Station indoor/outdoor controller
XCH-1000	10-Station indoor/outdoor controller
XCH-1200	12-Station indoor/outdoor controller
XCH-1200-SS	12-Station outdoor controller, stainless steel

OPTIONS	
Options*	Description
XCHSPOLE	Steel mounting pole (4 ft H)
XCHSPB	Stainless steel mounting bracket (required for pole)
458200	DC-Latching solenoid
SPXCH	Solar Panel kit for XC Hybrid

Notes:
* Specify separately. Use DC-Latching Solenoids only.

CONTROLLERS

PCC

Application: **Residential/Light Commercial**
 Number of Stations: **6, 9, 12, 15**
 Type: **Fixed**

FEATURES

- Number of stations: 6, 9, 12, 15
- Type: Fixed
- Enclosures: Indoor and outdoor
- Independent programs: 3
- Start times per program: 4
- Max. station run time: 6 hrs
- Warranty period: 2 years
- Optional lighting specific programs provide independent irrigation & lighting control (requires Pro-C/FX facepack upgrade: P/N 526205)
- ▶ Easy Retrieve memory
- ▶ Programmable rain delay
- ▶ Quick Check
- ▶ Non-volatile memory
- ▶ Automatic short circuit protection
- ▶ Seasonal adjustment: Global, or automatic updates with Solar Sync™
- ▶ Delay between stations
- ▶ Sensor programmability
- ▶ Total run time calculator
- ▶ Non-Water Days

ELECTRICAL SPECIFICATIONS

- Transformer input: 120 VAC or 230/240 VAC (international model)
- Transformer output (24 VAC): 1 A
- Station output (24 VAC): 0.56 A
- P/MV output (24 VAC): 0.28 A
- Sensor inputs: 1
- Operating temperature: 0° F to 140° F

APPROVALS

- CE, UL, cUL, C-tick, FCC

▶ = Advanced Feature descriptions on pages 73 and 74



Plastic indoor
 8¼" H x 9½" W x 3¾" D



Plastic outdoor
 9" H x 10" W x 4½" D



Optional Pro-C/FX Facepack
 Provides irrigation and lighting programs to be controlled from the Pro-C (P/N 526205)

USER INSTALLED OPTIONS (Specify Separately)

Options	Description
526205	Pro-C FX upgrade facepack provides lighting control independent of irrigation control. Up to 3 lighting transformers can be controlled using new programs L1, L2, & L3. (Use of a single lighting transformer reduces the total number of irrigation stations available by 1)

PCC - SPECIFICATION BUILDER: ORDER 1 + 2 + 3 + 4

1 Models	2 Transformer	3 Indoor/Outdoor	4 Options
PCC-6 = 6 stations PCC-9 = 9 stations PCC-12 = 12 stations PCC-15 = 15 stations	00 = 120VAC 01 = 230/240 VAC	(blank) = Outdoor model i = Indoor model	(blank) = No option E = 230/240 VAC with European connections A = 230/240 VAC with Australian connections (Australian outdoor models have internal transformer with cord)

Examples:
 PCC-1200i - A = 12-Station indoor controller 230/240 VAC and plastic cabinet
 PCC-600 = 6-Station outdoor controller 120 VAC and plastic cabinet
 PCC-901i - E = 9-Station indoor controller 230/240 VAC and plastic cabinet

CONTROLLERS

PRO-C

Application: **Residential/Light Commercial**
 Number of Stations: **3 to 15**
 Type: **Modular**

FEATURES

- Number of stations: 3 to 15
- Type: Modular
- Enclosures: Indoor and outdoor
- Independent programs: 3
- Start times per program: 4
- Max. station run time: 6 hrs
- Optional lighting specific programs provide independent irrigation & lighting control (requires Pro-C/FX facepack upgrade: P/N 526205)
- ▶ Easy Retrieve memory
- ▶ One touch manual start and advance
- ▶ Rain sensor bypass
- ▶ Programmable rain delay
- ▶ Quick Check
- ▶ Non-volatile memory
- ▶ Automatic short circuit protection
- ▶ Seasonal adjustment: Global, or automatic updates with Solar Sync™
- ▶ Delay between stations
- ▶ Sensor programmability
- ▶ Total run time calculator
- ▶ Non-Water Days



Plastic indoor
8¼" H x 9½" W x 3¾" D



Plastic outdoor
9" H x 10" W x 4½" D



Modular Expansion
Pro-C's Modular version allows easy expansion after initial installation.



Optional Pro-C/FX Facepack
Provides irrigation and lighting programs to be controlled from the Pro-C (P/N 526205).

ELECTRICAL SPECIFICATIONS

- Transformer input: 120 VAC or 230/240 VAC (international model)
- Transformer output (24 VAC): 1 A
- Station output (24 VAC): 0.56 A
- P/MV output (24 VAC): 0.28 A
- Sensor inputs: 1
- Operating temperature: 0° F to 140° F

APPROVALS

- CE, UL, cUL, C-tick, FCC

▶ = Advanced Feature descriptions on pages 73 and 74

EXPANSION MODULES

Station Expansion Modules	Description
PCM-300	3-Station plug-in module: Use to increase station count from 3 to 6, 6 to 9, and 9 to 12
PCM-900	9-Station plug-in module: Use to increase station count from 6 to 15 only

PRO-C - SPECIFICATION BUILDER: ORDER 1 + 2 + 3

1 Base Models	2 Indoor/Outdoor	3 Options
<p>PC-300i = 3-Station outdoor Pro-C controller, internal transformer</p> <p>PC-301 = International version 3-Station outdoor Pro-C controller, internal transformer</p>	<p>(blank) = Outdoor model</p> <p>i = Indoor model (Plug-in transformer)</p>	<p>(blank) = No option</p> <p>E = 230/240 VAC with European connections</p> <p>A = 230/240 VAC with Australian connections (Outdoor model has internal transformer with cord)</p>

Examples:

- PC-300i = 3-Station indoor base unit, and plastic cabinet
- PC-600i = 3-Station indoor base unit, one PCM-300 module, and plastic cabinet
- PC-900i = 3-Station indoor base unit, two PCM-300 modules, and plastic cabinet
- PC-1200 = 3-Station outdoor base unit, three PCM-300 modules, and plastic cabinet
- PC-1500 = 3-Station outdoor base unit, one PCM-300 module, one PCM-900 module, and plastic cabinet
- PC-601i - E = 3-Station indoor base unit, one PCM-300 module, 230/240 VAC, and plastic cabinet

I-CORE

Application: **Commercial**
 Number of Stations: **6 to 42**
 Type: **Modular**

FEATURES

- Number of stations: 6 to 42 (48 stations with DUAL decoders)
- Type: Modular
- Enclosure: Outdoor-plastic or metal
- Independent programs: 4
- Start times per program: 8 (A, B, C); 16 (D)
- Max. station run time: 12 hrs
- Warranty period: 5 years
- ▶ Real time flow monitoring
- ▶ Easy Retrieve™ memory
- ▶ One touch manual start and advance
- ▶ Rain sensor bypass
- ▶ Programmable rain delay
- ▶ Quick Check
- ▶ Non-volatile memory
- ▶ Automatic short circuit protection
- ▶ Seasonal adjustment
 - Global, by user
 - Monthly, by program
 - Automatic, by Solar Sync™
- ▶ Delay between stations
- ▶ Sensor programmability
- ▶ Total run time calculator
- ▶ Cycle and soak
- ▶ No water window
- ▶ Non-Water Days
- ▶ Multi-language programming: English Spanish, French, Italian, German, Portuguese



Plastic wall mount
11" H x 13¼" W x 4¾" D



Metal wall mount (gray powder-coated or stainless)
12¾" H x 15½" W x 6⅞" D



Metal pedestal (gray powder-coated or stainless)
36" H x 15½" W x 5" D



Plastic pedestal
38¾" H x 21⅞" W x 15¾" D



Modular Expansion
I-Core's unique "bridge" modules activate the existing terminal strips.

ELECTRICAL SPECIFICATIONS

- Transformer input: 120/240 VAC, 50/60 Hz
- Transformer output (24 VAC): 1.4 A
- Dual voltage transformer (120/240 VAC)
- Station output (24 VAC): 0.56 A
- Simultaneous station operation: 2 automatic, 5 manual
- Pump/Master Valve (24 VAC): 0.28 A
- Sensor inputs: Plastic: 2; Metal: 3
- Operating temperature: 0° F to 140° F

APPROVALS

- CE, UL, cUL, C-tick, FCC
- Enclosure rating
 - Steel wall mounts: IP-56
 - Plastic pedestal: IP-24
 - Plastic wall-mount: IP-44

▶ = Advanced Feature descriptions on pages 73 and 74

I-CORE	
Model	Description
IC-600-PL	6-Station controller, indoor/outdoor, plastic cabinet
IC-601-PL	International version, 6-Station controller, indoor/outdoor, plastic cabinet
IC-600-M	6-Station controller, indoor/outdoor, metal cabinet
IC-600-PP	6-Station controller, indoor/outdoor, plastic pedestal
ICM-600	6-station plug-in expansion module
IC-600-SS	6-Station controller, indoor/outdoor, stainless steel cabinet
ACC-PED	Metal pedestal, gray powder-coated, use with I-Core and ACC metal controllers
PED-SS	Stainless pedestal for use with I-Core and ACC stainless controllers

ENCLOSURE TYPES & EXPANSION	
Enclosure Type	Expands To
Plastic cabinet	30 Stations
Metal/stainless cabinet	42 Stations
Plastic pedestal	42 Stations
Stainless cabinet	42 Stations

DUAL

Application: **Commercial**
 Number of Stations: **6 to 48**
 Type: **Decoder Output for I-Core**

FEATURES

- Two-wire decoder system for I-Core controllers
- Decoder station sizes available: 1, 2
- Dual-S external surge arresters
- Field programmable:
 - Dual decoder module display and push button programming makes it easy to program decoders at the controller itself
 - Dual decoders can be field programmed with the Hunter ICD-HP. No need to remove decoders from the two-wire path.
- Decoder module displays decoder operation and diagnostic information
- Can operate up to 48 stations of combined decoder and conventional control, making system retrofit easy
- Waterproof connectors for connection to two-wire path included with all Dual decoders and DUAL-S surge arrester
- Solenoid finder feature assists in locating valves in the field
- Number of 2-wire paths: 3
- ▶ Includes all features of the I-Core controller, plus decoder operations
- ▶ Programmable decoders
- ▶ Wireless programming with Hunter ICD-HP
- ▶ Color-coded ID wire
- ▶ Waterproof connectors included

DUAL SPECIFICATIONS

- Max. recommended distance, decoder to solenoid: 100 ft.
- Max. distance to decoder
 - 14 AWG wire path: 5,000 ft.
 - 12 AWG wire path: 7,500 ft.

APPROVALS

- CE, UL, cUL, C-tick, FCC

▶ = Advanced Feature descriptions on pages 73 and 74

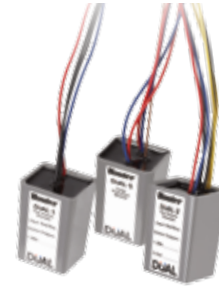

Dual decoders and surge arrester
 3" H x 1¾" W x 2" D



DUAL decoder module
 1¾" H x 4¾" W x 4" D

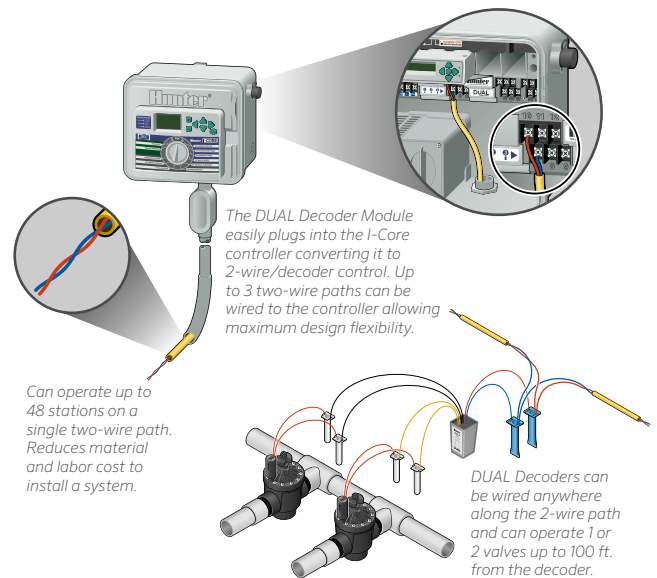

CONTROLLERS

DUAL		
Base model	Plus	Description
IC-600-PL	DUAL48M	48-Station controller, indoor/outdoor, plastic cabinet
IC-601-PL	DUAL48M	International version, 6-Station controller, indoor/outdoor, plastic cabinet
IC-600-M	DUAL48M	48-Station controller, indoor/outdoor, metal cabinet
IC-600-PP	DUAL48M	48-Station controller, indoor/outdoor, plastic pedestal
IC-600-SS	DUAL48M	48-Station controller, indoor/outdoor, stainless steel cabinet

Dual Model	Description
DUAL48M	Dual decoder output module. Plug-in module converts any I-Core controller to 2-wire decoder system (up to 48 stations maximum)
DUAL-1	DUAL 1-station decoder (includes 2 DBRY-6 connectors)
DUAL-2	DUAL 2-station decoder (includes 2 DBRY-6 connectors)
DUAL-S	Dual surge arrester (includes 4 DBRY-6 connectors)

ID WIRE MODEL GUIDE			
14 AWG Standard Decoder Cable		12 AWG Long Range, Heavy-Duty Decoder Cable	
ID1GRY	Gray jacket	ID2GRY	Gray jacket
ID1PUR	Purple jacket	ID2PUR	Purple jacket
ID1YLW	Yellow jacket	ID2YLW	Yellow jacket
ID1ORG	Orange jacket	ID2ORG	Orange jacket
ID1BLU	Blue jacket	ID2BLU	Blue jacket
ID1TAN	Tan jacket	ID2TAN	Tan jacket

ID WIRE MAXIMUM WIRE RUNS	
ID 1 Wire	ID 2 Wire
5,000 ft. with I-Core/Dual systems	7,500 ft. with I-Core/Dual systems
10,000 ft. with ACC/ICD systems	15,000 ft. with ACC/ICD systems

ACC

Application: **High-End Commercial**
 Number of Stations: **12 to 42**
 Type: **Modular**

FEATURES

- Number of stations: 12 to 42
- Type: Modular
- Enclosure: Outdoor
- Independent programs: 6
- Start times per program: 10
- Max. station run time: 6 hrs
- Warranty period: 5 years
- ▶ Real time flow monitoring
- ▶ Easy Retrieve™ memory
- ▶ One touch manual start and advance
- ▶ Programmable rain delay
- ▶ Non-volatile memory
- ▶ Automatic short circuit protection
- ▶ Seasonal adjustment: ACC
 - Global, by user
 - Individually, by program
 - Automatic, by Solar Sync
- ▶ Delay between stations
- ▶ Sensor programmability: Individual shutdown by program
- ▶ Total run time calculator
- ▶ Cycle and soak
- ▶ No Water Window
- ▶ Simultaneous station groups

ELECTRICAL SPECIFICATIONS

- Transformer input: 120/240 VAC, 50/60 Hz
- Transformer output (24 VAC): 4.0 A
- Dual voltage transformer (120/240 VAC)
- Station output (24 VAC): 0.56 A
- P/MV output (24 VAC): 0.32 A
- Pump/master valve: 2, normally closed
- Sensor inputs: 4, plus 1 Flow Meter
- Operating temperature: 0° F to 140° F

APPROVALS

- CE, UL, cUL, C-tick, FCC
- Enclosure rating
 - Steel wall mounts: IP-56
 - Plastic pedestal: IP-24

ALL STAINLESS STEEL (SS) MODELS

- American-made Type 304 Stainless Steel 0.057" gauge steel
- Passivated for corrosion resistance

▶ = *Advanced Feature descriptions on pages 73 and 74*



Metal wall mount (gray powder-coated or stainless)
 12¾" H x 15½" W x 6¼" D



Metal pedestals (gray powder-coated or stainless)
 37" H x 15½" W x 5" D
 (pedestal only)



Plastic pedestal
 38¾" H x 21¼" W x 15½" D



ACM-600
 Optional Extreme Service high-lightning 6-station output module.



AGM-600
 Standard 6-station output module with heavy-duty surge protection.

ACC	
Model	Description
ACC-1200	12-Station base unit controller, expands to 42 stations, metal cabinet
ACC-1200-SS	12-station base unit controller, stainless steel cabinet
ACC-1200-PP	12-Station base unit controller, expands to 42 stations, plastic pedestal
ACC-PED	Metal pedestal, grey powder-coated, for use with I-Core and ACC metal controllers
PED-SS	Stainless steel pedestal for use with I-Core and ACC stainless controllers

EXPANSION MODULES	
Station Expansion Modules	Description
ACM-600	6-Station plug-in module for use with the ACC-1200 series controllers
AGM-600	6-Station plug-in module for use with the ACC-1200 series controllers (extreme service lightning protection version)

ACC-99D

Application: **High-End Commercial**
 Number of Stations: **1 to 99**
 Type: **Decoder**

FEATURES

- Includes all standard features of the ACC
- Decoder station sizes available: 1, 2, 4, 6
- Sensor decoder available with Flow and Clk inputs
- Max. distance to decoder
 - 14 AWG wire path: 10,000 ft.
 - 12 AWG wire path: 15,000 ft.
- Max. recommended distance, decoder to solenoid: 150 ft.
- Field programmable decoders
- ICD-HP wireless handheld programmer compatible
- Two-way communications
- Surge suppression: Internal (ground wire included)
- Dual pump/master valve outputs may be assigned to decoders
- Wire path connectors included with each decoder
- Number of wire paths: 6
- Automatic daily weather-based scheduling with optional Hunter Solar Sync™ sensor

ELECTRICAL SPECIFICATIONS

- Transformer input: 120/230VAC, 50/60 Hz, 2A max at 120V, 1A max at 230V
- Transformer output: 24VAC, 4A, @ 120VAC
 - Decoder Line (path) output: 34V peak-to-peak
 - Decoder Power draw: 40 mA per active output
 - Solenoid capacity: 2 standard 24 VAC Hunter solenoids per output within 150 ft. runs, up to 14 solenoids max simultaneous (includes dual P/MV outputs)
- Wiring, Decoder to solenoid: standard pair 18 AWG/1 mm to 150 ft. (twisted improves surge resistance)
- 6 two-wire output paths to field decoders
- Two-way confirmation of decoder activation
- Two-way monitoring of sensor connections (ICD-SEN)
- Diagnostic LEDs with line status, signal activity, decoder and status
- Programmable decoder station IDs (from controller panel)

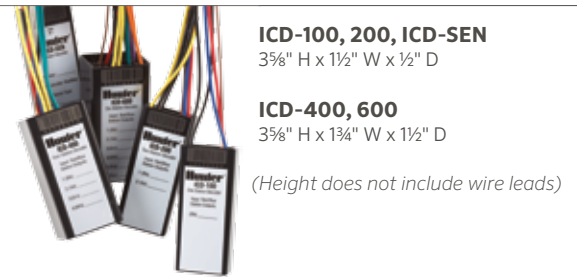

ICD-100, 200, ICD-SEN
3 3/8" H x 1 1/2" W x 1 1/2" D

ICD-400, 600
3 3/8" H x 1 3/4" W x 1 1/2" D

(Height does not include wire leads)

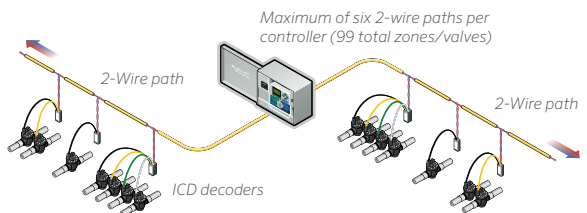

ID WIRE MODEL GUIDE

14 AWG Standard Decoder Cable		12 AWG Long Range, Heavy-Duty Decoder Cable	
ID1GRY	Gray jacket	ID2GRY	Gray jacket
ID1PUR	Purple jacket	ID2PUR	Purple jacket
ID1YLW	Yellow jacket	ID2YLW	Yellow jacket
ID1ORG	Orange jacket	ID2ORG	Orange jacket
ID1BLU	Blue jacket	ID2BLU	Blue jacket
ID1TAN	Tan jacket	ID2TAN	Tan jacket

MAXIMUM WIRE RUNS

ID 1 Wire	ID 2 Wire
5,000 ft. with I-Core/Dual systems	7,500 ft. with I-Core/Dual systems
10,000 ft. with ACC/ICD systems	15,000 ft. with ACC/ICD systems

ACC-99D DECODER	
Model	Description
ACC-99D	2-Wire decoder controller with 99 station capacity, metal cabinet
ACC-99D-SS	2-Wire decoder controller with 99 station capacity, stainless steel wall mount
ACC-99D-PP	2-Wire decoder controller with 99 station capacity, plastic pedestal
ACC-PED	Metal pedestal, gray powder-coated, for use with I-Core and ACC metal controllers
PED-SS	Stainless steel pedestal for use with I-Core and ACC stainless controllers

DECODER MODULES	
Decoder Model*	Description
ICD-100	Single-station decoder with surge suppression and ground wire
ICD-200	2-station decoder with surge suppression and ground wire
ICD-400	4-station decoder with surge suppression and ground wire
ICD-600	6-station decoder with surge suppression and ground wire
ICD-SEN	2-input sensor decoder with surge suppression and ground wire

Notes:
 * Specify separately. Each decoder includes 2 waterproof connectors for red and blue wires.

CONTROLLERS

ICD-HP

Application: **Commercial**
 Type: **Decoder Programmer**

FEATURES

- Program or re-program decoder stations, whether new or installed
- Program any station numbers in any order, or skip stations for future expansion
- Simplifies setup and diagnostics for sensor decoders
- Sensor test functions for Klik and Flow sensors, plus built-in multimeter
- Waterproof programming cup
- Communicates with decoder through plastic case—wireless electro-magnetic induction saves waterproof connectors
- Compatible with Hunter ICD or Dual series decoders
- USB powered for shop or office use; 4 x AA batteries for field use
- All test leads and cables included in durable, foam-padded carrying case
- Turn decoder stations on and view solenoid status, current in milliamps, and more
- Backlit adjustable display
- 6 international operating languages



ICD-HP

3 7/8" H x 8 1/4" W x 2" D
 Handheld programmer, includes all test and power leads, programming cup, and rugged carrying case

ELECTRICAL SPECIFICATIONS

- Power input: 4 x AA batteries, or standard USB connector (included)
- Communications: Wireless induction, range 1" (25 mm)
- Fused test leads for unpowered decoder functions

APPROVALS

- FCC, CE, C-tick (no license required)

ICD-HP



ICD-HP	
Model	Description
ICD-HP	Wireless handheld decoder programmer, includes all test and power leads, programming cup, and rugged carrying case

PSR

Application: **Residential/Commercial**
 Type: **Accessory**

FEATURES

- Three models available to fit your particular application
- NEMA 3R rated locking plastic enclosure rated for outdoor use, weather resistance and security
- 24 VAC flying leads make it quick and easy to wire to controller
- The PSR-22 meets demanding electrical requirements for UL approval, and the PSR-52/-53 contain UL-approved relays



Compact design
 Enclosure measures
 6½" H x 7½" W x 4½" D

PUMP START RELAY

Model	Description
PSR-22	Double pole/single throw pump start relay for 120 VAC pumps up to 1.5 kW or 240 VAC pumps up to 3.7 kW
PSR-52	Double pole/single throw pump start relay for 120 VAC pumps up to 2.2 kW or 240 VAC pumps up to 5.6 kW
PSR-53	Triple pole/single throw pump start relay for 120 VAC pumps up to 2.2 kW, 240 VAC pumps up to 5.6 kW, or 240 VAC pumps up to 7.5 kW (three phase)
PSRB	Used to boost controller output power available to operate larger pump start relays if necessary

PUMP START RELAY ELECTRICAL SPECIFICATIONS

Models	Single Phase		3 Phase	Max Full Load AMPS	Max Resistive AMPS	Coil VA		Coil VA	
	hp AT 110 VAC	hp AT 240 VAC	hp AT 240 VAC			IN-RUSH (AMPS)	(AMPS)	HOLDING (AMPS)	(AMPS)
PSR-22	2*	5*	N/A	22	30	31	(1.29)	7	(0.29)
PSR-52	3	7.5	N/A	40	40	56	(2.33)	6	(0.25)
PSR-53	3	7.5	10	40	50	56	(2.33)	6	(0.25)

Notes:

* Approximate power

ROAM

Application: **Residential/Commercial**
 Range: **up to 1,000 ft.**
 Type: **Remote**

FEATURES

- Designed to work with Hunter X-Core, Pro-C, PCC, I-Core and ACC controllers through a SmartPort® connection
- 128 programmable addresses for use with multiple Roam remotes in the same neighborhood
- Run manual watering cycles without modifying regular program
- Maximum stations supported: 240
- Programmable run times: 1 to 90 minutes
- Range: Up to 1,000 ft. (line of sight)
- Transmitter power source: 4 AAA batteries (included)
- Receiver power source: 24 VAC, 10 mA (provided by controller)
- System operating frequency: 433 MHz
- FCC approved
- Warranty: 2 years



Transmitter and Receiver
 7" H x 2¼" W x 1¼" D



SmartPort®
 Hunter remotes require the installation of a SmartPort wiring harness*. The SmartPort is a connector that is wired to the terminals on the controller, and allows quick connection to any Hunter remote.

Wall Mount Bracket for SmartPort
 P/N 258200

** ACC and I-Core controllers include pre-wired SmartPorts for remote operation.*

ROAM	
Model	Description
ROAM-KIT	Transmitter, receiver (SmartPort® wiring harness, and 4 AAA batteries included)
ROAM-R	Receiver unit
ROAM-TR	Transmitter unit (4 AAA batteries included)

OPTIONS	
Options	Description
ROAM-WH	SmartPort wiring harness (length: 6 ft. pack of 50)
SRR-SCWH	Shielded SmartPort wiring harness (length: 25 ft.)
258200	Wall Mount Bracket for SmartPort

CONTROLLERS

ROAM XL

Application: **Commercial**
 Range: **up to 2 miles**
 Type: **Remote**

FEATURES

- Up to 2 mile range for remote manual operation of Hunter irrigation systems
- Designed to work with Hunter X-Core, Pro-C, PCC, I-Core and ACC controllers through a SmartPort® connection
- 128 different programmable addresses
- Display shows remaining battery life
- Maximum stations supported: 240
- Programmable Run Times: 1 to 90 minutes
- Large LCD display, push-button operation
- Run manual watering cycles without modifying regular program
- Transmitter power source: 4 AAA batteries (included)
- Receiver power source: 24 VAC, 10 mA (provided by controller)
- System operating frequency: 27 MHz band
- SmartPort connector can be mounted up to 50' (max) from controller (use SRR-SCWH shielded cable wiring harness)
- No FCC license required
- Rugged plastic carrying case included
- Warranty: 5 years



Transmitter (no antenna)

6½" H x 3¼" W x 1¼" D

Receiver (no antenna)

6¼" H x 3" W x 1¼" D



SmartPort®

Hunter remotes require the installation of a SmartPort wiring harness*. The SmartPort is a connector that is wired to the terminals on the controller, and allows quick connection to any Hunter remote.

* ACC and I-Core controllers include pre-wired SmartPorts for remote operation.



Wall Mount Bracket for SmartPort

P/N 258200

ROAM XL	
Model	Description
ROAMXL-KIT	Transmitter, receiver, SmartPort® wiring harness, and carrying case
ROAMXL-TR	Handheld transmitter (4 AAA batteries included)
ROAMXL-R	Receiver unit (SmartPort wiring harness included)
ROAMXL-CASE	Plastic carrying case
ROAM-WH	SmartPort wiring harness (length: 6 ft., pack of 50)
SRR-SCWH	Shielded SmartPort wiring harness (length: 25 ft.)

OPTIONS	
Options	Description
258200	Wall Mount Bracket for SmartPort

NODE

Application: **Residential/Commercial**
 Number of Stations: **1, 2, 4, 6**
 Type: **Battery Operated/Fixed**

FEATURES

- Battery powered
- Type: Fixed
- Number of stations: 1, 2, 4, 6
- Enclosure: Outdoor
- Independent programs: 3
- Start times per program: 4
- Max. station run time: 6 hrs
- Operates DC latching solenoids only
- Accepts single or double 9 volt batteries for extended battery life
- Master Valve operation (available in 2, 4, 6 station models)
- Solar Panel Kit (SPNODE) provides maintenance free operation
- Programmable Off
- Manual Cycle
- Solenoid wire length up to 100 ft. (18 AWG)
- Warranty period: 2 years
- ▶ Easy Retrieve™ memory
- ▶ Global seasonal adjustment
- ▶ Sensor compatibility
- ▶ Battery life indicator
- ▶ Waterproof body

ELECTRICAL SPECIFICATIONS

- Operates DC latching solenoids only (P/N 458200)
- Pump/master valve
- Sensor inputs: 1
- Operating temperature: 0° F to 140° F

POWER SOURCE

- 9-volt battery (up to two) or Solar Panel

APPROVALS

- IP68, CE

▶ = *Advanced Feature descriptions on pages 73 and 74*



NODE-100
3½" diameter x 2½" tall



NODE-200
NODE-400
NODE-600



NODE-100-Valve
NODE-100-Valve-B
(BSP thread)

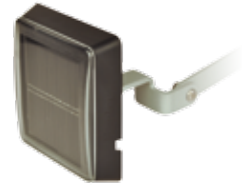

Optional Solar Panel
3¼" H x 3" W x ⅝" D

MAXIMUM WIRE RUNS

Wire Size	Max Distance (ft.)
18 AWG	100

OPTIONS

Options*	Description
458200	DC latching solenoid
SPNODE	Solar Panel kit for Node

Notes:
* Specify separately

NODE	
Model	Description
NODE-100	Single station controller (DC latching solenoid included)
NODE-200	2-Station controller (DC latching solenoid ordered separately)
NODE-400	4-Station controller (DC latching solenoid ordered separately)
NODE-600	6 station controller (DC latching solenoid ordered separately)
NODE-100-VALVE	Single station controller with PGV-101G valve and DC latching solenoid (NPT threads)
NODE-100-VALVE-B	Single station controller with PGV-101G-B valve and DC latching solenoid (BSP threads)

WVP & WVC

Application: **Residential/Commercial**
 Number of Stations: **1, 2, 4**
 Type: **Battery Operated/Fixed**

FEATURES

- Battery powered
- Type: Fixed
- Number of stations: 1, 2, 4
- Enclosure: Outdoor
- Program by station
- Start times per program: 9
- Max. station run time: 4 hrs
- Warranty period: 2 years
- ▶ Battery life indicator
- ▶ Waterproof body (WVC)
- ▶ Wireless remote programming

ELECTRICAL SPECIFICATIONS

- Simultaneous station operation
 - Example: a 2 station WVC-200 can operate 2 stations simultaneously, and a 4 station WVC-400 can operate all 4 at the same time
- Sensor inputs: 1
- Power source: 9-volt battery
- Operates DC latching solenoids only (P/N 458200)
- Operating temperature: 0° F to 140° F
- Frequency: 900 MHz ISM band
- No FCC license required

APPROVALS

- IP68, CE

▶ = Advanced Feature descriptions on pages 73 and 74



WVP
11½" L x 3" W x 2" H



WVC
3¼" diameter x 5" tall

MAXIMUM WIRE RUNS	
Wire Size	Max Distance (ft.)
18 AWG	100

WVP / WVC	
Model	Description
WVC-100	Single station wireless controller (DC latching solenoid ordered separately) 900 MHz ISM band (US/Australia)
WVC-200	2-Station wireless controller (DC latching solenoid ordered separately) 900 MHz ISM band (US/Australia)
WVC-400	4-Station wireless controller (DC latching solenoid ordered separately) 900 MHz ISM band (US/Australia)
WVC-100-E	Single station wireless controller (DC latching solenoid ordered separately) 869.85 MHz (Europe)
WVC-200-E	2-Station wireless controller (DC latching solenoid ordered separately) 869.85 MHz (Europe)
WVC-400-E	4-Station wireless controller (DC latching solenoid ordered separately) 869.85 MHz (Europe)
WVP	Wireless valve programmer to be used with wireless valve controllers
WVPE	Wireless valve programmer to be used with wireless valve controllers (Europe)

CONTROLLERS

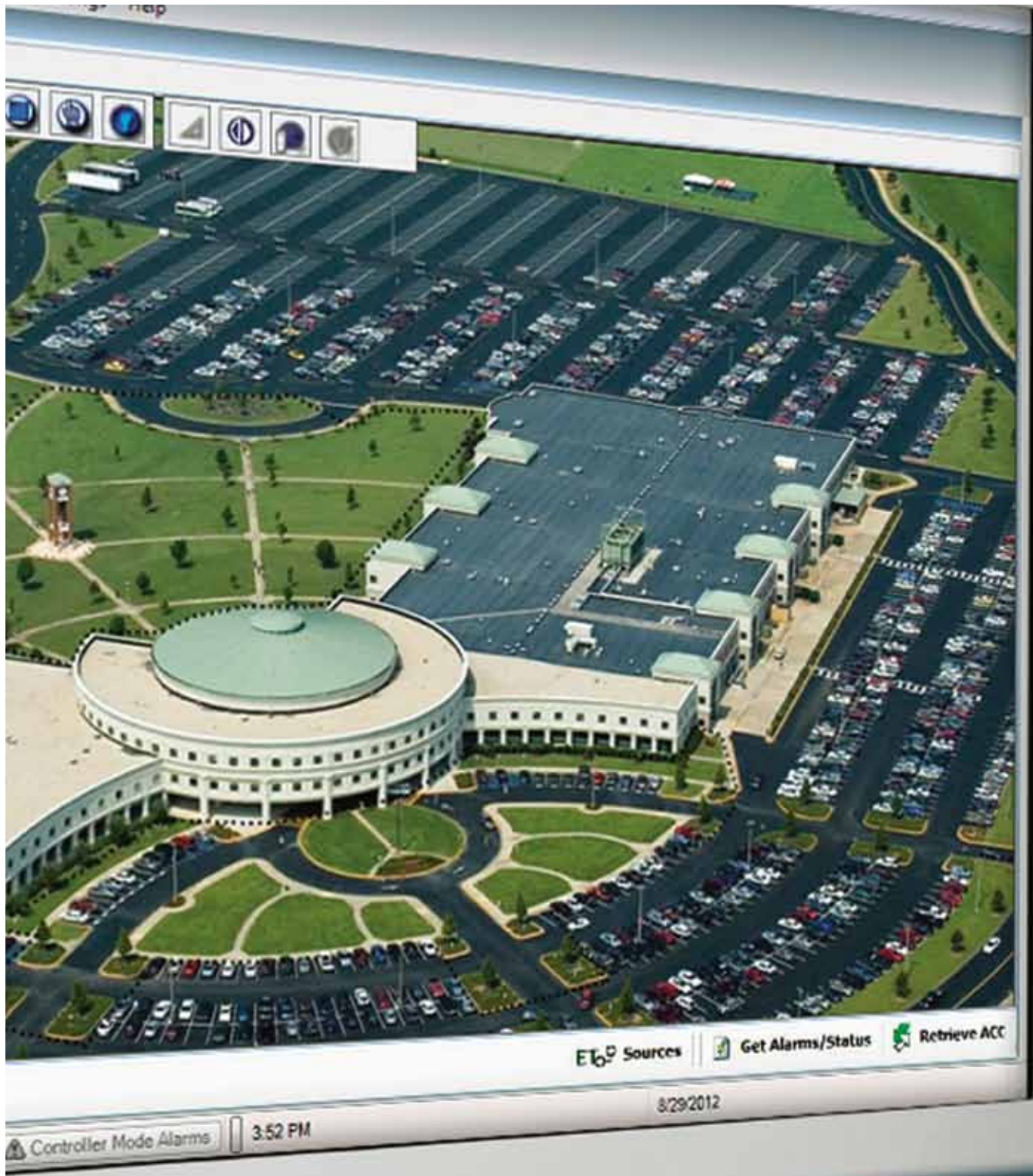

CENTRAL

ADVANCED FEATURES

Maps

The IMMS graphics update includes the ability to create one or more map views for control purposes. You can see where all of your irrigated locations are, and click any for a more detailed view or control purposes.

Ideal for orienting new employees, IMMS Graphics also simplifies life for busy irrigators with large numbers of assets to control. Use any background image to show the system, site, or controller area, and create control zones and station symbols that link to their command functions. You supply the pictures, and IMMS includes all the tools you need to create an interactive map-based system.

IMMS-ET (Evapotranspiration)

Take the guesswork out of irrigation amounts and daily adjustments for weather conditions. The optional IMMS-ET software add-on uses cost-effective local sensors, combined with your station database (for plant types, soil, precipitation rate, and more) to create water-saving irrigation programs for your whole system, every day.

IMMS-ET models the moisture level in soil reservoirs (including compensation for natural rainfall) and schedules just enough irrigation to replace what your plants need. IMMS-ET can track climate history according to your own sensors and document how it has responded with irrigation adjustments.

Programming

Each controller has its own complete setup and operations screens with tools to quickly and easily get the results you want. Eliminate the confusion and hassle of multiple field personnel setting up irrigation with dials and buttons. Shut off irrigation with a mouse click for emergencies. Access every function of controllers from simple spreadsheets or choosing from a menu of common functions and commands.

Alarm Management

IMMS reports all alarms, including over-currents, flow violations, communication issues, and water window violations, with individual date- and time-stamped messages. The IMMS operator knows the state of all irrigation controllers and valves at a glance, without driving around town to check individual sites. Printable reports can be exported to other formats or handed to work crews for investigation.

Flow Monitoring

Track your water usage, and spot plumbing problems a mile away (or several hundred miles away). IMMS is built around the powerful ACC controller platform, which includes real-time flow monitoring. With a flow meter and normally-closed master valves, the ACC detects incorrect flow conditions and moves swiftly to isolate the offending valves. Each flow violation is reported to the central software, after the controller has finished its own diagnostics. Leaks, breaks, and flooding are minimized, and the irrigation manager is the first to know of any issues.

IMMS also tracks total water usage by site, controller, program, and station. Keep detailed historical records, and go home each day with the peace of mind given by automatic flow monitoring.

IMMS

Sites: **100+**
 Controllers: **1,000+**
 Number of Stations: **Up to 990,000**

FEATURES

- Windows-based programming and communications software
- Total control of each controller's functions
- Graphical user interface with customizable map-based navigation
- Flow monitoring and reporting with Hunter ACC controllers
- Alarm reporting and detailed irrigation history reports
- Wireless and hardwired communication options, including Ethernet and GPRS
- Controller sharing of communication channels to reduce communications costs
- ▶ Maps (now including AutoCAD import)
- ▶ Programming
- ▶ IMMS-ET (evapotranspiration)
- ▶ Alarm management
- ▶ Flow monitoring
- ▶ Solar Sync compatibility allows inexpensive self-adjustment at each controller



Add a visual dimension to central control with background map graphics.

KEY SPECIFICATIONS

- Operating system: Microsoft Windows XP, Vista, Windows 7, Windows 8 (32 or 64 bit)
- Minimum RAM: 512 MB
- Minimum screen resolution: 1024 x 768
- Storage: At least 100 MB disk space



Track flow and other vital statistics in both charts and spreadsheets.

COMPATIBLE CONTROLLERS

- IMMS is optimized for the Hunter ACC controller and accessories (including decoder controllers)

COMPATIBLE SENSORS

- Hunter Flow-Sync™ for ACC controllers (one per controller). Provides flow total reporting and flow alarm monitoring with diagnostic shutdowns in real time.
- Clik Sensors: Each controller should have its own rain sensor or Solar Sync sensor for fast rain shutdowns. All Hunter Clik sensors are compatible with ACC.
- Solar Sync™ Sensor: Individual controllers may now self-adjust with Hunter's innovative Solar Sync sensor, which will report the local adjustments to central software.
- ET Sensor: ET Sensor platform is for use with IMMS-ET software. ET Sensor is added to selected ACC controllers, to report local conditions. This local ET data has no additional monthly charges and can be shared through the software to create schedules for other controllers in the same micro-climate. Add as many ET Sensors as needed to sample all micro-climates.

▶ = Advanced Feature descriptions on page 90



Station level symbols can be positioned over background images from any source.

IMMS SOFTWARE	
Model	Description
IMMS3CD	IMMS graphics central control software (Custom images not included)
IMMS-ET-CD	Optional ET automatic weather adjustment software (requires IMMS3CD base model; Requires an ET Sensor at one or more ACC controller locations)



Local ET Sensor, includes Rain Gauge (shown with optional ET Wind anemometer)

IMMS

COMMUNICATIONS COMPONENTS

- ACC: Communications options are installed inside the ACC controller cabinet. No additional enclosures or power are necessary for these options.
- Options include radio, hardwire, dial-up, Ethernet, and GPRS mobile communications

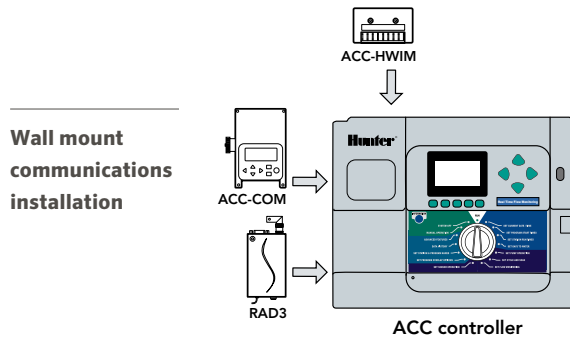

Plastic pedestal communications installation

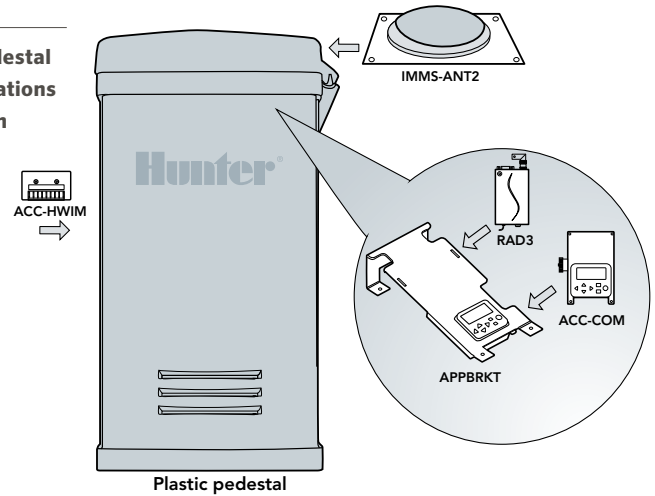

COMMUNICATION OPTIONS FOR ACC INTERFACE

Model	Purpose
ACC-COM-HWR = Hardwire/radio module*	Supports hardwire and radio communication options
ACC-COM-POTS = Dial-up modem module*	Supports dial-up analog telephone line input in addition to hardwire and radio communication sharing (not for use with VoIP lines)
ACC-COM-GSM = CSD cellular module*	Supports GSM mobile input in addition to hardwire and radio communication sharing (cell service required)
ACC-COM-LAN = Ethernet module*	Supports TCP/IP in Ethernet networks in addition to hardwire and radio sharing with local controllers
ACC-COM-GPRS = GPRS cellular data module*	Supports mobile data connection via GPRS phone in addition to hardwire and radio sharing with local controllers

Notes:

* Also supports radio and hardwire

USER-INSTALLED OPTIONS (Specify Separately)

Model	Description	Purpose
ACC-HWIM	Hardwire interface module required for hardwire connections	Provides surge protected terminals for hardwired cable connections
RAD3	UHF radio module (North America), 450-470 MHz	UHF radio module for wireless connections (license and antenna required and not included)
APPBRKT	Communication bracket for plastic pedestals	Holds Com modules and accessories in plastic pedestal (not required in wall mounts)

Base	Model	Options	Purpose
IMMS-CCC	HARDWIRE CENTRAL INTERFACE	None = 120 VAC (North America) E = 230/240 VAC (Europe/international power) A = 230/240 VAC (Australia)	Hardwired central interface for connection to Site via direct wire (GCBL cable), supplied with USB cable for connection to central computer, and plug-in transformer
GCBL*	100 = 100 FT 300 = 300 FT 500 = 500 FT		Cable for all IMMS hardwired communications

Notes:

* GCBL also available in 1,000 ft. increments (up to 4,000 ft.)

IMMS

SPECIFICATIONS

- ACC-COM-HWR, POTS, GSM, LAN, GPRS
- 3¼" x 4½" x 1¾"
- Powered internally via data connection
- Mounted internally to ACC controller
- RAD3: 450-470 MHz, UHF Radios, Power Output: 1 Watt, Bandwidth: 12.5 kHz narrowband
- ACC-HWIM: Hardwire interface module for 4-20 ma loop communications, includes 8 color-coded terminals for GCBL connection. Installs inside ACC controller cabinets or pedestals.
- ACC-COM-LAN requires fixed IP address from system administrators
- ACC-COM-GPRS requires a monthly service plan

HARDWIRE COMMUNICATIONS CABLE

- GCBL shielded, two twisted pair 18 AWG wire with ground wire, up to 10,000' between each device

RADIO ANTENNA OPTIONS (Specify Separately)

Model	Description
IMMSANT2	Omni-directional antenna for plastic pedestal lid installation
IMMSANT3	Omni-directional antenna for wall or pole mount installation
IMMSANTYAGI3	High efficiency directional antenna for pole installation
RA5M	High gain omni-directional mast antenna for roof or pole installations

IMMS

SYSTEM CONFIGURATIONS (ACC CONTROLLERS)

- 1 Determine how you will reach the first controller on each Site.
 - Dial-up landline: Add ACC-COM-POTS to controller
 - Hardwire cable: Add one IMMS-CCC at the computer, and ACC-COM-HWR plus one ACC-HWIM at the controller
 - GSM cell phone: Add ACC-COM-GSM to controller (requires CSD service plan)
 - Ethernet local area network: Add ACC-COM-LAN at the controller, and connect to the network (RJ-45 jack)
 - GPRS cell phone: Add ACC-COM-GPRS to controller (requires GPRS coverage and service contract)
- 2 Determine how that first controller will reach the other controllers on the Site.
 - If by radio, add one RAD3 plus antenna to the controller plus antenna to the controller
 - If by hardwire cable, add one ACC-HWIM (if it is not already present as in 1)
- 3 Equip the other controllers. Add one ACC-COM-HWR to each controller, plus:
 - One ACC-HWIM when hardwire connection will be necessary
 - One RAD3 plus antenna when radio connections are necessary

Consult factory for detailed system design information.

SAMPLE CONFIGURATIONS

- Many other configurations possible; consult factory or System Design Guide for details.

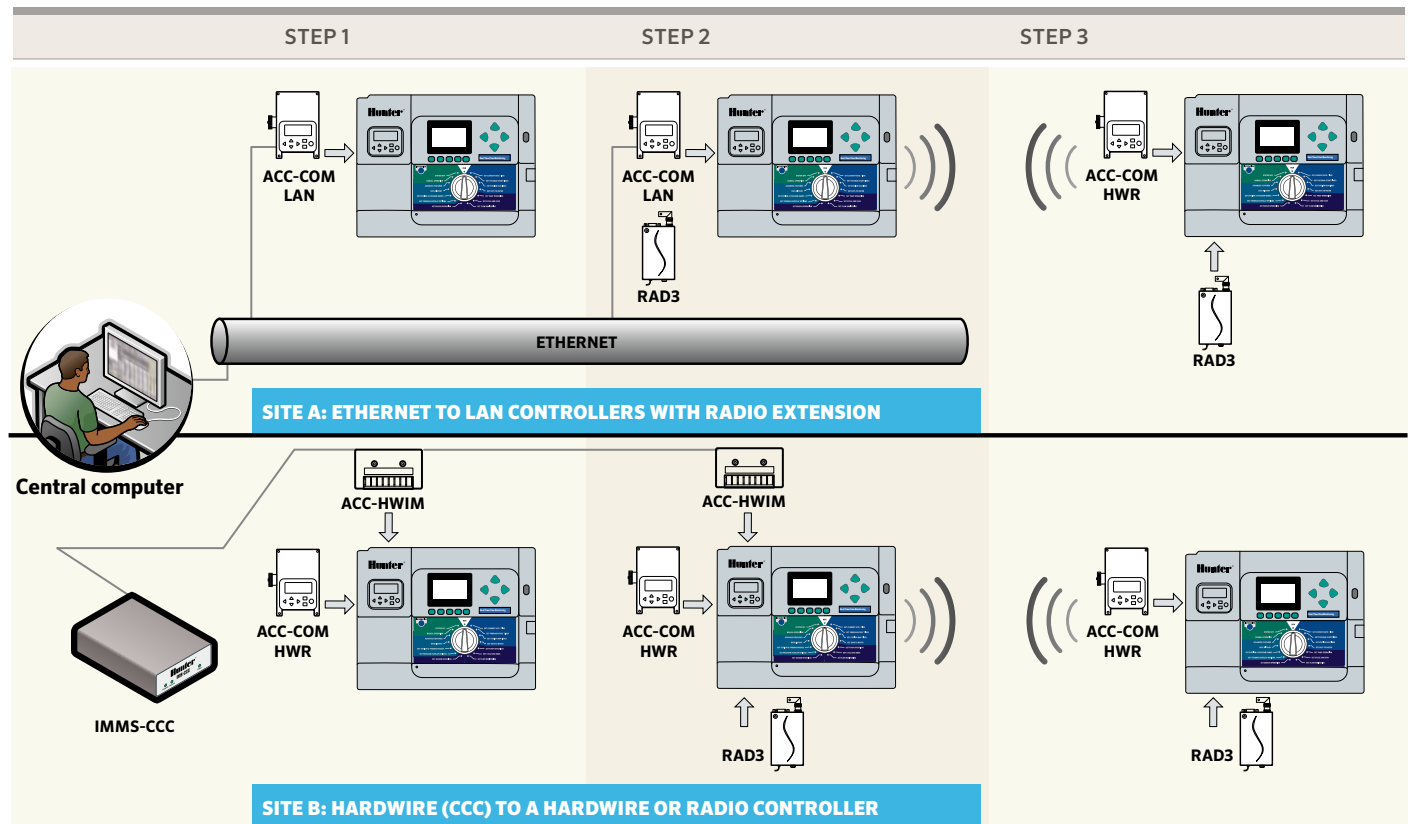

CENTRAL

SENSORS



SENSORS



SENSORS

SOLAR SYNC™

Application: **Residential/Commercial**
 Sensor: **ET/Rain/Freeze**

FEATURES

- Provides automated daily adjustment to program run times using ET (evapotranspiration) calculated from on-site weather
- Wired and wireless models available
- No Water Window programming available in most controllers
- Maximum range from controller: 200 ft. (wired model) or 800 ft. (wireless model)
- Rain and freeze shutoff
- Gutter mount bracket included
- Solar Sync Sensor may be used (without ET Module) in IMMS central installations
- Warranty period: 5 years (10 year battery warranty for wireless model)

ELECTRICAL SPECIFICATIONS

- Maximum distance sensor to module: 200 ft. (wired model) or 800 ft. (wireless model)
- 40 ft. of wire included in kit (wired model)
- Solar Sync and Wireless Solar Sync compatible with Pro-C and PCC controllers
- Solar Sync SEN and Wireless Solar Sync SEN are compatible with X-Core, I-Core, and ACC controllers
- Rain and Freeze sensor shutdown capability included in sensor

APPROVALS

- FCC, CE



Solar Sync sensor with mounting arm
 3" H x 8½" W x 1" D



Solar Sync module
 1¾" H x 5" W x ¾" D



Wireless Solar Sync sensor with mounting arm
 4½" H x 8½" W x 1" D



Wireless Solar Sync receiver
 5½" H x 1½" W x 1½" D

SENSORS

SOLAR SYNC		
Model	Description	
SOLAR-SYNC	Solar Sync kit for use with PCC and Pro-C controllers. <i>Includes Solar Sync Sensor and module.</i>	
SOLAR-SYNC-SEN	Solar Sync for use with ACC, I-Core• and X-Core controllers. <i>Includes Solar Sync Sensor only (module not needed for X-Core, I-Core• and ACC controllers).</i>	
WSS	Wireless Solar Sync for use with PCC and Pro-C controllers. <i>Includes Wireless Solar Sync Sensor, Wireless receiver, and module.</i>	
WSS-SEN	Wireless Solar Sync for use with ACC, I-Core• and X-Core controllers. <i>Includes Wireless Solar Sync Sensor and Wireless receiver (module not required for X-Core and ACC controllers).</i>	

*Available for I-Core Spring of 2013

ET SYSTEM

Application: **Commercial**
Sensor: **ET**

FEATURES

- Calculates evapotranspiration (ET) for individual microclimate to fit the exact landscape requirements
- Specific irrigation scheduling for every zone based on the characteristics of each plant and soil type
- Enables compliance with local watering restrictions
- Easily upgrades Hunter PCC and Pro-C to weather-based controllers
- Non-volatile memory
- Full range of scheduling options
- Includes 100 ft. of 18 AWG, 2-conductor direct burial wire for sensor installation
- WiltGard™ technology can be set to trigger protective watering when extreme conditions threaten plants
- Warranty period: 2 years

ELECTRICAL SPECIFICATIONS

- Power input: 24 VAC, 50/60 Hz (from host controller)
- Current draw: 20 mA, maximum
- Max distance Controller to ET Module: 6'
- Max. distance, ET Sensor to module: 100'
- Sensor wire: Includes 100 ft. of 18 AWG UL approved wire



ET Sensor
10½" H x 7¼" W x 12½" D



ET Module
6" H x 4" W x 1¾" D

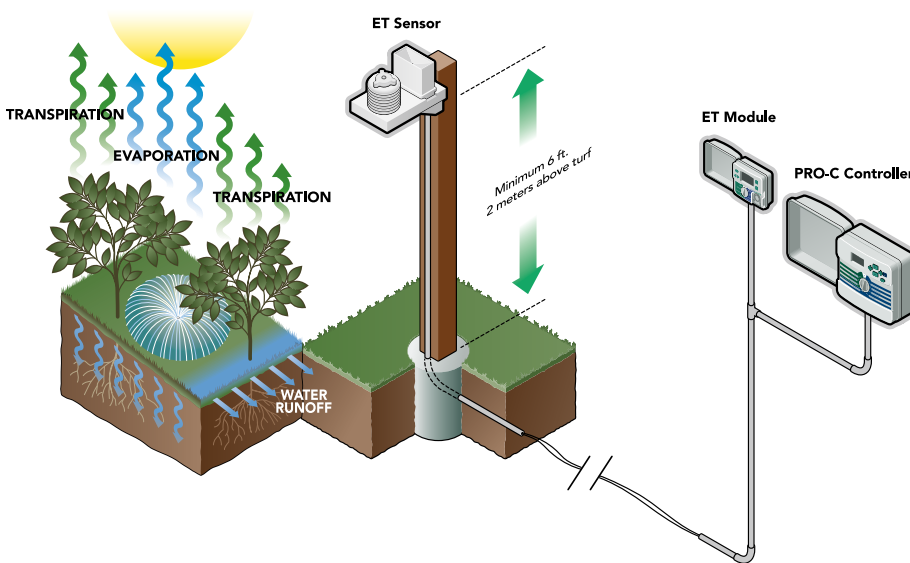

ET SYSTEM

Model	Description
ET-SYSTEM	ET Sensor and module for use with PCC and Pro-C controllers
ET-WIND	Optional anemometer add-on to ET Sensor to gather wind speed data
ET-SENSOR	Sensor only for use with IMMS-ET installations

SENSORS

RAIN-CLIK™

Application: **Residential/Commercial**
Sensor: **Rain**

FEATURES

- Quick Response™ feature shuts the system off as soon as it starts raining
- Maintenance-free design with 10-year battery life for Wireless Rain-Clik
- Adjustable vent ring allows for setting of reset delay
- Rugged polycarbonate housing and metal extension arm
- Rain-Clik includes 25 ft. of 20 AWG sheathed, two-conductor, UL-approved wire
- Wireless unit available with 800 ft. range from wireless sensor to receiver
- Compatible with most controllers
- Warranty period: 5 years (10 year battery warranty for wireless model)

ELECTRICAL SPECIFICATIONS

- Wiring: normally closed or normally open
- Time to turn off irrigation system: 2 to 5 minutes approx. for Quick Response
- Time to reset Quick Response: 4 hours approx. under dry, sunny conditions
- Time to reset when fully wet: 3 days approx. under dry, sunny conditions
- UL listed, CUL (CSA), CE
- Switch rating: 24 VAC, 3 A
- Freeze sensor shuts system off when temperatures fall below 37° F (Rain/Freeze-Clik model)
- System operating frequency: 433 MHz (Wireless model)
- UL listed, FCC approved, suitable for use in Australia, CUL (CSA), CE
- Communication range up to 800 ft. line of sight (Wireless model)
- Rain/Freeze-Clik shuts system off when temperatures fall below 37° F
- Receiver input power: 24 VAC (from controller)



WR-CLIK-TR
(with metal arm)
3" H x 8" L



RAIN-CLIK
2½" H x 7" L



WR-CLIK-R
3¼" W x 4" H



SGM
Optional gutter mount

RAIN-CLIK™

Model	Description
RAIN-CLIK	Rain-Clik sensor
RFC	Rain/Freeze-Clik sensor
WR-CLIK	Wireless Rain-Clik system
WRF-CLIK	Wireless Rain/Freeze-Clik system

USER INSTALLED OPTION (Specify Separately)

Model	Description
SGM	Optional gutter mount (included in the WRF-CLIK)

MINI-CLIK®

Application: **Residential/Commercial**

Sensor: **Rain**

FEATURES

- Easily installs on any automatic irrigation system
- Debris tolerant for reliable operation and no unnecessary shutdowns
- Can be set to shut system off from 1/8" to 1" of rainfall
- Includes 25' of 20 AWG sheathed, two-conductor, UL-approved wire
- Optional user-installed metal gutter mount for Mini-Click® (order SGM)
- Warranty period: 5 years

ELECTRICAL SPECIFICATIONS

- Switch rating: 24 VAC, 5 A
- Wiring: 20 AWG, UL listed, typically interrupts the common ground wire between the solenoid valves and controller

USER INSTALLED OPTIONS

- SGM = Optional gutter mount
- SG-MC = Stainless steel sensor guard enclosure for Mini-Click



MINI-CLIK
8 cm H x 15 cm L



SGM
Optional gutter mount



SG-MC
Stainless steel sensor guard enclosure for Mini-Click

MINI-CLIK®	
Model	Description
MINI-CLIK	Rain Sensor
MINI-CLIK-NO	Rain Sensor w/ normally open switch
MINI-CLIK-C	Rain Sensor w/ conduit mount
MINI-CLIK-HV	Rain Sensor for high voltage application (120/240 VAC)

USER INSTALLED OPTIONS (Specify Separately)	
Model	Description
SGM	Optional Gutter Mount
SG-MC	Stainless Steel Sensor Guard Enclosure for Mini-Click

SENSORS

MINI WEATHER STATION

Application: **Residential/Commercial**
 Sensor: **Wind/Freeze/Rain**

FEATURES

- Compact sensor that monitors wind, rain, freezing temperatures, and shuts the irrigation system off as weather conditions require
- Installs easily on automatic irrigation systems
- Set wind speed shutdown from 12 to 35 mph
- Set rain shutdown from 1/8" to 1" of rainfall
- Automatically shuts off system when temperatures fall below 37° F
- Warranty period: 5 years

ELECTRICAL SPECIFICATIONS

- Electrical rating: 24 VAC, 5 A maximum
- Wind vane diameter: 5"
- Wind speed adjustments: Actuation speed: 12 to 35 mph
- Reset speed: 8 to 24 mph
- Freeze-Clik® temperature set point: 37° F
- Mounts: Slip fits over 2" PVC pipe or attaches to 1/2" conduit with adapter (supplied with unit)



MWS
 4" H x 5" D wind vane diameter

MINI WEATHER STATION	
Model	Description
MWS	Weather station combines wind & rain
MWS-FR	Weather station combines wind & rain sensors with a freeze sensor

SENSORS

WIND-CLIK™

Application: **Residential/Commercial**
 Sensor: **Wind**

FEATURES

- Adjusts to activate and reset at various wind speeds
- Two types of operation: "normally open" or "normally closed" wiring
- Works with fountain systems to eliminate overspray in windy conditions
- Warranty period: 5 years

ELECTRICAL SPECIFICATIONS

- Switch rating: 24 VAC, 5 A maximum
- Wind speed adjustment
 - Actuation speed: 12 to 35 mph
 - Reset speed: 8 to 24 mph



WIND-CLIK
 4" H x 5" D wind vane diameter

WIND-CLIK™	
Model	Description
WIND-CLIK	Wind sensor interrupts/returns irrigation when programmed wind speed is measured

FLOW-CLIK™

Application: **Residential/Commercial**
 Sensor: **Flow**

FEATURES

- Automatically shuts down system if an overflow condition occurs
- Calibration for precise system control: Single button allows each system to be programmed at a specified flow level
- Helps protect against flood damage and erosion
- Works with most Hunter and most non-Hunter controllers
- Multi-color LED provides system status to display when power is applied, and indicate if flow is within limits
- Compatible with most commercial and residential piping systems: Large flow range provides complete flexibility
- Warranty period: 5 years

ELECTRICAL SPECIFICATIONS

- Flow-Clik Interface Panel 36" leads provided for easy wiring to controller (2 wires to controller 24 VAC terminals and 2 wires to sensor and terminals)
- Current draw: 24 VAC, 0.025 A
- Switching current: 2 A maximum
- Max. distance between interface panel and sensor: 1,000 ft. (18 AWG minimum wire size); 2 wires required for Flow-Clik sensor
- Programmable start up delay: 0 to 300 seconds
- Programmable interrupt period: 2 to 60 minutes
- System status indicator light
- One button system calibration to set highest flow zone

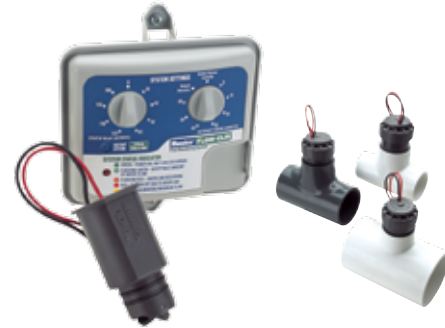

Flow-Clik sensor and module shown with receptacle tees

FLOW-CLIK™	
Model	Description
FLOW-CLIK*	Standard kit for all 24 VAC controllers. Includes sensor and interface module, sensor requires FCT for pipe installation

USER INSTALLED OPTION (Specify Separately)	
Model	Description
FCT-100	1" Schedule 40 sensor receptacle tee
FCT-150	1½" Schedule 40 sensor receptacle tee
FCT-158	1½" Schedule 80 sensor receptacle tee
FCT-200	2" Schedule 40 sensor receptacle tee
FCT-208	2" Schedule 80 sensor receptacle tee
FCT-300	3" Schedule 40 sensor receptacle tee
FCT-308	3" Schedule 80 sensor receptacle tee
FCT-400	4" Schedule 40 sensor receptacle tee

Notes:
 * FCT for pipe installation sold separately

FLOW-CLIK FLOW RANGE		
Pipe Diameter	Operating range (GPM)	
	Minimum	Suggested Maximum*
1"	6	17
1½"	13	35
2"	20	55
3"	40	120
4"	60	200

Notes:
 * Good design practice dictates the maximum flow not to exceed 5ft./sec. Suggested maximum flow is based upon Class 200 IPS plastic pipe

FLOW-SYNC™

Application: **Commercial**
 Sensor: **Flow**

FEATURES

- Simple two-wire connection to ACC and I-Core controllers (up to 1,000 ft.)
- Feeds flow data (gallons or liters) to controller, for flow recording and monitoring purposes
- Robust waterproof construction (used with appropriate FCT tees for pipe diameter, see table)
- Provides station level flow monitoring for reaction to high or low flow conditions
- Helps prevent damage and waste from leaks and breaks in piping system



Impeller-type flow meter, requires FCT for pipe installation (sold separately)

FLOW RANGE

Flow-Sync Diameter	Operating range (GPM)	
	Minimum	Suggested Maximum*
1"	2	17
1½"	5	35
2"	10	55
3"	28	120
4"	34	195

Notes:

* Good design practice dictates the maximum flow not to exceed 5ft./sec. Suggested maximum flow is based upon Class 200 IPS plastic pipe

HFS

Model	Description
HFS*	Flow-Sync sensor, use with ACC and I-Core controllers, sensor requires FCT for pipe installation.

USER INSTALLED OPTION (Specify Separately)

Model	Description
FCT-100	1" Schedule 40 sensor (white) receptacle tee
FCT-150	1½" Schedule 40 sensor (white) receptacle tee
FCT-158	1½" Schedule 80 sensor (gray) receptacle tee
FCT-200	2" Schedule 40 sensor (white) receptacle tee
FCT-208	2" Schedule 80 sensor (gray) receptacle tee
FCT-300	3" Schedule 40 sensor (white) receptacle tee
FCT-308	3" Schedule 80 sensor (gray) receptacle tee
FCT-400	4" Schedule 40 sensor (white) receptacle tee

Notes:

* FCT for pipe installation sold separately

FREEZE-CLI™

Application: **Residential/Commercial**
 Sensor: **Freeze**

FEATURES

- Installs easily with no adjustment needed
- Accurate temperature sensing shuts system off when air temperature reaches 37° F
- Used with other sensors to enhance overall efficiency of irrigation systems
- Warranty period: 5 years

Not intended for agricultural applications

ELECTRICAL SPECIFICATIONS

- Switch rating: 24 VAC, 5 A
- Wiring: Typically interrupts the common ground wire between the solenoid valves and the controller UL listed



FREEZE-CLI™
 2" H x 6" L

FREEZE-CLI™

Model	Description
FREEZE-CLI™	Freeze sensor interrupts irrigation when temperatures drop below 37° F
FREEZE-CLI™ REV	Freeze sensor allows irrigation when temperatures drop below 37° F



MICRO

MICRO



MICRO

ECO-MAT

Application: **Residential/Commercial/
Green Roof Turf & Shrub Irrigation**

Flow Rate: **0.6 GPH**

FEATURES

- Fleece irrigation mat with fleece-wrapped PLD tubing (ECO-MAT)
- Fleece-wrapped PLD tubing (PLD-ESD)
- Pressure compensating/check valve emitter
- 0.6 GPH emitter
- Water holding capacity of 0.5 gallon per square yard
- 12" emitter spacing, 14" row spacing
- 32" width x 295' length
- 250 ft. roll (PLD-ESD 17 mm)
- Recommended for use with all Hunter Drip Zone Control Kits

OPERATING SPECIFICATIONS

- Pressure compensating, check valve emitters
- Operating pressure 15 to 50 PSI
- Compatible with 17 mm insert barb fittings
- Recommended filtration 120 mesh
- Recommended installation depth range 4" to 12"

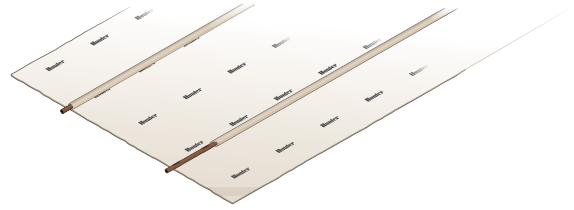

Eco-Mat

Dripline cover (special polypropylene fleece), mat made of special polypropylene fleece, PLD dripline



PLD-ESD

Fleece-wrapped inline emitter tubing

ECO-MAT™ TECHNICAL SPECIFICATIONS

Model	Flow & Spacing	Roll Length	Width	Ft ²	Operating Pressure	Minimum Filtration	Tubing Row Spacing
Eco-Mat 17 mm	0.6 GPH/12"	295'	32"	785'	20-50 PSI	120 mesh/125 micron	14"
PLD-ESD 17 mm	0.6 GPH/12"	250'	N/A	N/A	20-50 PSI	120 mesh/125 micron	N/A

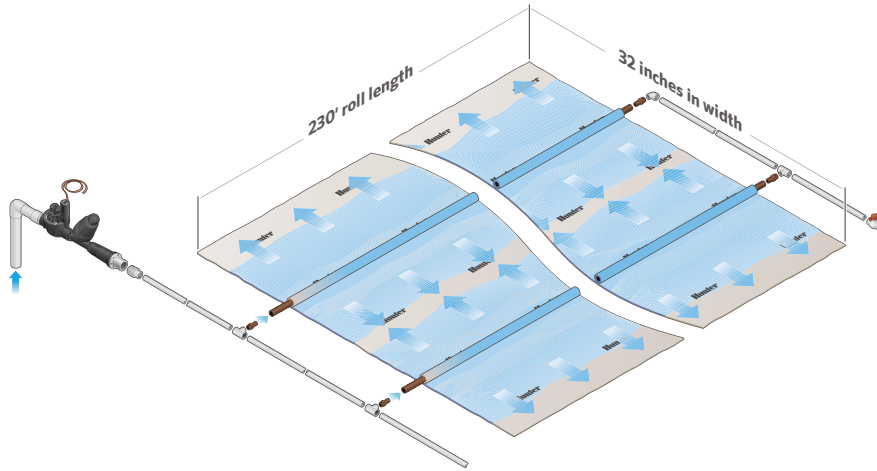

Eco-Mat

The Eco-Mat is composed of Hunter's specialized fleece-wrapped drip tubing (PLD-ESD), and root zone irrigation mat made of polypropylene fleece.

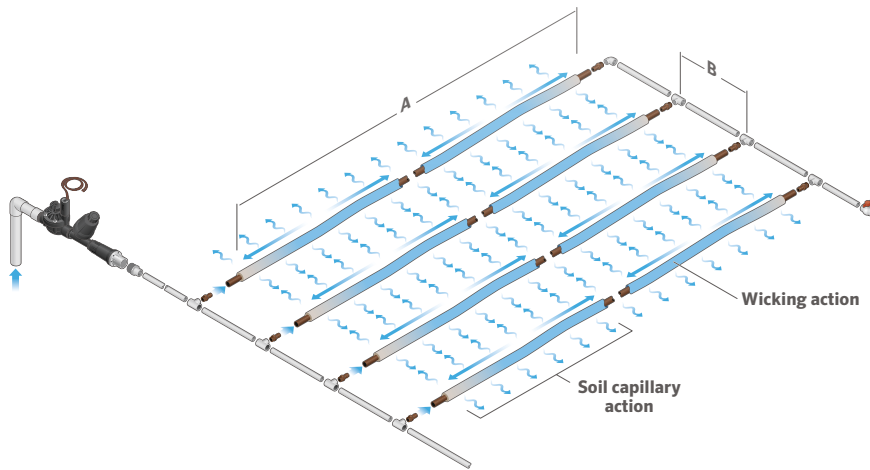

PLD-ESD

The PLD-ESD provides enhanced lateral water movement, which is dramatically more efficient than unwrapped drip tubing where water is drawn downward into the ground. Length A and row spacing B are dependent on design and site conditions.

Installation depth guidelines (below)

The Eco-Mat should be installed just below the optimal root depth to efficiently deliver water to a variety of turfs, plants, and shrubs.

Note: Eco-Mat is not intended for the irrigation of trees.

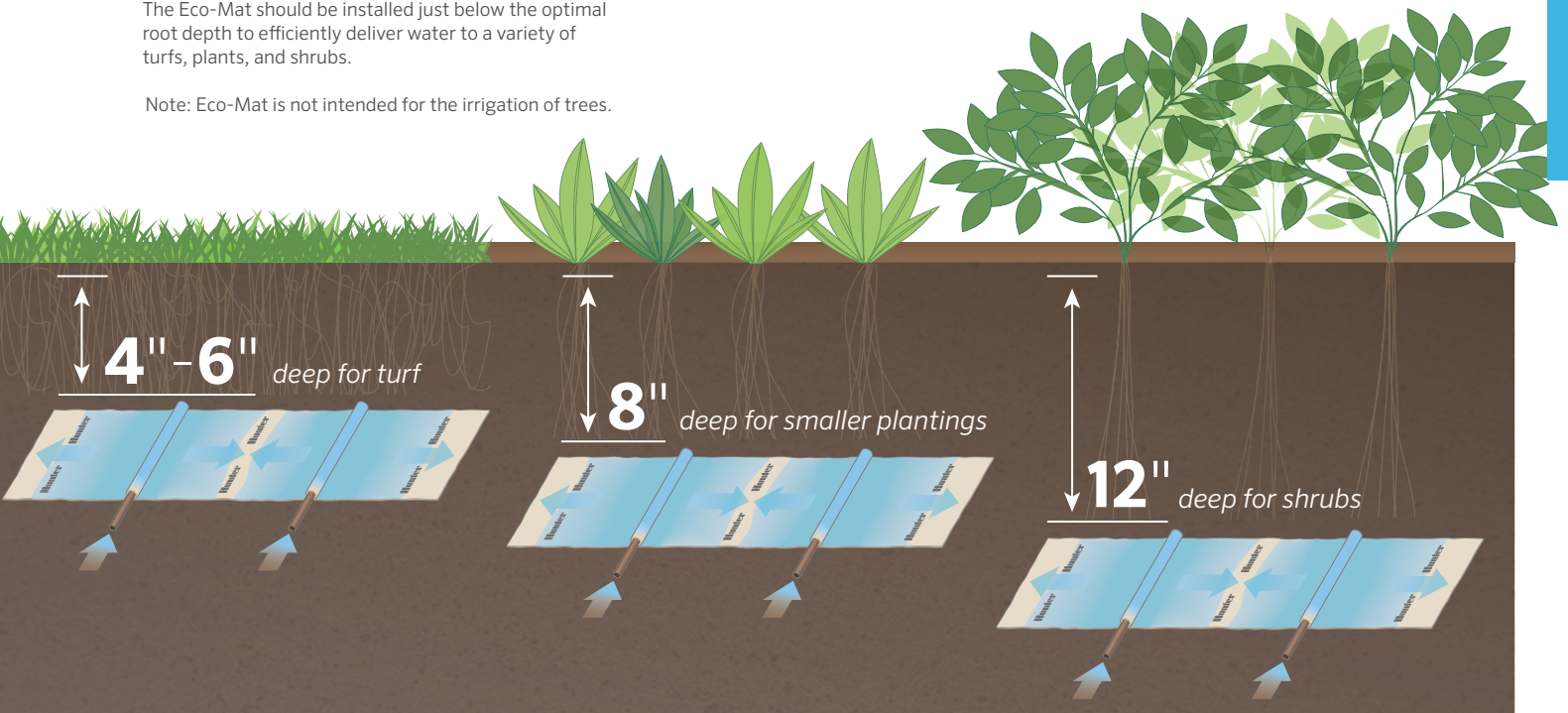

PLD

Application: **Residential/Commercial**
Flow Rate: **0.4, 0.6, 1.0 GPH**

FEATURES

- In-line pressure-compensating emitters provide consistent high-quality performance
- Built-in check valve prevents emitter clogging and wasteful runoff
- Superior flexibility and kink resistance
- Available emitter spacing of 12", 18", or 24"
- Emitter flow rates available in 0.4, 0.6, or 1.0 GPH
- Blank tubing available (no emitters)
- Comes in 100, 250 and 1,000 ft. rolls (100 ft. rolls available in models PLD 0612100, PLD 1012100, and PLD 1018100)
- Purple (reclaimed) color available in 0.6 and 1.0 GPH emitter models
- Works with Drip Zone Control Kits
- Warranty period: 5 years (including 2 additional years for environmental stress cracking)

PLD FITTING FEATURES

- Ideal for use with all PLD drip line products
- Quick and easy connections without using tools or glue
- UV resistant
- Same color as PLD drip line for a perfect blend under mulch

OPERATING SPECIFICATIONS

- Pressure compensating, non-draining emitters
- Operating pressure range: 15 to 50 PSI
- Recommended filtration: 120 mesh
- Accepts 17 mm insert fittings

PLD & PLD Fittings



PLD



PLD-050
1/2" MPT x 17 mm barb



PLD-075
3/4" MPT x 17 mm barb



PLD-CPL
17 mm barb x barb coupling



PLD-ELB
17 mm barb x barb 90° elbow



PLD-TEE
17 mm barb x barb tee



PLD-CAP
17 mm barb x 1/2" MPT with cap



PLD-BV
17 mm barb x barb shut-off valve



PLD-075-TBTEE
3/4" Female thread x 17 mm barb tee



PLD-AVR
1/2" threaded air/vacuum relief valve

PLD INSERT FITTINGS

Model	Description	Model	Description
PLD050	Barb to 1/2" NPT Adapter	PLDCAP	Barb to End Cap
PLD075	Barb to 3/4" NPT Adapter	PLDBV	Barbed Valve
PLDCPL	Barb to Barb Coupling	PLD075TBTEE	3/4" Female Thread x 17 mm Barb Tee
PLDELB	Barb to Barb, 90° Elbow	PLDAVR	Air Relief Valve
PLDTEE	Barbed Tee		

Additional charts located on page 129

PLD - SPECIFICATION BUILDER: ORDER 1 + 2 + 3 + 4

1 Model	2 Spacing	3 Length	4 Options
PLD-04 = 0.4 GPH Flow	12 = 12"	100* = 100'	R = Reclaimed
PLD-06 = 0.6 GPH Flow	18 = 18"	250 = 250'	
PLD-10 = 1.0 GPH Flow	24 = 24"	1K = 1,000'	
PLD-BLNK = Blank			

Examples:

PLD-04 - 12 - 250 = 0.4 GPH landscape dripline with 12" spacing in a 250' roll
PLD-06 - 12 - 100 = 0.6 GPH landscape dripline with 12" spacing in a 100' roll
PLD-10 - 24 - 250 - R = 1.0 GPH landscape dripline with 24" spacing in a 250' roll, with reclaimed option

PLD-BLNK - 100 = 100' Roll of blank tubing
PLD - AVR = 1/2" MPT air relief/anti-vacuum valve

Notes:

* 100' rolls only available in models PLD-BLNK, PLD-06-12-100, PLD-10-12-100, and PLD-10-18-100.

Reclaimed models available in 0.6 and 1.0 GPH only and do not contain check valves.

MICRO SPRAYS

Application: **Residential/Commercial**
 Uses: **Precise Area Watering**

SOLO-DRIP

- Eight streams of water for accurate watering
- Fingertip cap control for flow and radius adjustment
- Operating specifications: 15 to 30 PSI
- Dimensions:
 [A] SD-T: 0.95" H x 0.78" W x 0.63" D
 [B] SD-B: 0.95" H x 0.78" W x 0.63" D
 [C] SD-B-STK: 6.0" H x 1.7" W x 0.63" D



Solo-Drip

HALO-SPRAY

- Large diameter, umbrella of water
- Adjust radius as needed
- Combine several for a "blanket" of water
- Operating specifications: 15 to 30 PSI
- Dimensions:
 [A] HS-T: 0.95" H x 0.78" W x 0.63" D
 [B] HS-B: 0.95" H x 0.78" W x 0.63" D
 [C] HS-B-STK: 6.0" H x 1.7" W x 0.63" D



Halo-Spray

TRIO-SPRAY

- Full-, half-, and quarter-circle configurations
- Functions like big sprays on a micro level
- Control knob for specific adjustment
- Operating specifications: 10 to 30 PSI
- Dimensions:
 [A] TS-F: 1.5" H x 0.9" W x 0.6" D
 [B] TS-H: 1.5" H x 0.9" W x 0.6" D
 [C] TS-Q: 1.5" H x 0.9" W x 0.6" D



Trio-Spray

SOLO-DRIP PERFORMANCE DATA

	Pressure (PSI)	Flow (GPH)	Throw Diameter (FT.)
	15	0-11	0-1.5
20	0-12.5	0-1.9	
30	0-15.7	0-2.7	

Notes:
 Adjustable to Maximum (approx. 20 clicks)

HALO-SPRAY PERFORMANCE DATA

	Pressure (PSI)	Flow (GPH)	Throw Diameter (FT.)
	15	0-14	0-5.8
20	0-16	0-7.7	
30	0-20	0-11.5	

Notes:
 Adjustable to Maximum (approx. 14 clicks)

TRIO-SPRAY PERFORMANCE DATA

	Pressure (PSI)	Flow (GPH)	Spray Pattern		
			Diameter in Throw (in.)		Radius of Throw (in.)
			360° x 18 Hole	180°	90°
10	0-16.7	0-17	0-7	0-6	
15	0-20.3	0-19	0-8	0-7	
20	0-23.4	0-20	0-9	0-8	
25	0-26.1	0-22	0-10	0-9	
30	0-28.6	0-23	0-11	0-10	

MICRO SPRAY MODELS

Model	Description
SD-T	Solo-Drip w/ 10-32 Threads, 360°
SD-B	Solo-Drip w/ Barb, 360°
SD-B-STK	Solo-Drip w/ Barb with stake, 360°
HS-T	Halo-Drip w/ 10-32 Threads, 360°
HS-B	Halo-Drip w/ Barb, 360°
HS-B-STK	Halo-Drip w/ Barb with stake, 360°
TS-T-F	Trio-Spray w/ 10-32 Threads, 360°
TS-T-H	Trio-Spray w/ 10-32 Threads, 180°
TS-T-Q	Trio-Spray w/ 10-32 Threads, 90°

DRIP ZONE CONTROL KITS

Application: **Res/Com Micro Irrigation**
Flow Rate: **0.5 to 60 GPM**

FEATURES

- Factory-assembled and water-tested
- Highest quality components (SS filter screen, standard flush cap, top-of-the-line regulator)
- Filter Sentry™ diaphragm screen cleaning system on ICZ kits
- Wide flow range to cover most micro irrigation applications

FACTORY INSTALLED OPTIONS

- 25 or 40 PSI regulator (ACZ-075, PCZ-101, ICZ-101)

USER INSTALLED OPTIONS

- Reclaimed water ID handle for ACZ-075 and PCZ-101 (P/N 269205)
- Reclaimed water ID handle for ICZ-101 and ICZ-151 (P/N 561205)

ACZ-075

- Pressure regulation: 25 or 40 PSI
- Flow: 0.5 to 15 GPM (30 to 900 GPH)
- Operating pressure: 20 to 120 PSI
- Operating temperature: up to 150° F
- 150 mesh stainless steel screen

ICZ-101

- Pressure regulation: 25 or 40 PSI
- Flow: 2 to 20 GPM (120 to 1200 GPH)
- Operating pressure: 20 to 120 PSI
- Operating temperature: up to 150° F
- 150 mesh stainless steel screen

PCZ-101

- Pressure regulation: 25 or 40 PSI
- Flow: 0.5 to 15 GPM (30 to 900 GPH)
- Operating pressure: 20 to 120 PSI
- Operating temperature: up to 150° F
- 150 mesh stainless steel screen

ICZ-151

- Pressure regulation: 40 PSI
- Flow: 20 to 60 GPM
- Operating pressure: 20 to 120 PSI
- Operating temperature: up to 150° F
- 120 mesh stainless steel screen

SOLENOID OPERATING SPECIFICATIONS

- Heavy-duty solenoid: 24 VAC
350 mA inrush, 190 mA holding, 60 Hz (North America)
370 mA inrush, 210 mA holding, 50 Hz (most International locations)

Additional charts located on page 130.



ACZ-075
14¼" H x 11" L x 3" W
¾" inlet x ¾" outlet



PCZ-101
6" H x 13" W x 3" D
1" inlet x ¾" outlet



ICZ-101
6" H x 13" W x 3" D
1" inlet x 1" outlet



ICZ-151
12" H x 22" L x 12" D
1½" inlet x 1" outlet



HY075, HY100, HY175
(filter system sold separately)

DRIP ZONE CONTROL KITS – SPECIFICATION BUILDER: ORDER 1 + 2

1 Model	2 Options
ACZ-075 = ¾" PGV-ASV valve with ¾" HY075 filter system	25 = 25 PSI regulator (excluding ICZ-151)
PCZ-101 = 1" PGV globe valve with 1" HY100 filter system	40 = 40 PSI regulator
ICZ-101 = 1" ICV globe valve with 1" HY100 filter system	
ICZ-151 = 1½" ICV globe valve with 1½" HY100 filter system	

Examples:

- ACZ-075 - 25 = ¾" PGV-ASV valve with ¾" HY075 filter system, and 25 PSI regulator
- PCZ-101 - 25 = 1" PGV globe valve with 1" HY100 filter system, and 25 PSI regulator
- ICZ-101 - 40 = 1" ICV globe valve with 1" HY100 filter system, and 40 PSI regulator

RZWS

Application: **Res/Com Tree and Shrub Irrigation**

Size: **10", 18", 36"**

Flow Rate: **0.25 or 0.50 GPM**

FEATURES

- Built in Hunter Swing Joint for direct installation to ½" PVC fitting
- Patented StrataRoot baffles divert water to root zone while adding strength to the unit
- Locking cap

OPERATING SPECIFICATIONS

- Bubbler flow rates: 0.25 or 0.50 GPM
- Recommended pressure range: 15 to 70 PSI

FACTORY INSTALLED OPTIONS

- Check valve
- Locking reclaimed purple cap

USER INSTALLED OPTIONS

- Sleeve: Fabric sleeve that helps prevent soil intrusion in sandy soils (P/N RZWS-SLEEVE)
- Replacement cap 18" and 36" only (P/N RZWS-CAP)
- Locking reclaimed purple cap 18" and 36" only (P/N RZWS-RCCAP)
- Purple reclaimed cap spare part (P/N RZWS-RCCAP for 18 and 36 models. P/N RZWS10RCC for 10 models)

DIMENSIONS

- 10": 2" diameter x 10" length
- 18": 3" diameter x 18" length
- 36": 3" diameter x 36" length



Standard and reclaimed models available



Reclaimed models available. Add -R to model number.

Purple reclaimed cap spare part (P/N RZWS-RCCAP for 18" and 36" models. P/N RZWS10RCC for 10" models)

ROOT ZONE WATERING SYSTEM – SPECIFICATION BUILDER: Order 1 + 2 + 3

1 Model	2 Bubbler Flow Rate	3 Options
RZWS-10 = 10" Root zone watering system	25 = 0.25 GPM	(blank) = No option
RZWS-18 = 18" Root zone watering system	50 = 0.50 GPM	CV = Check valve
RZWS-36 = 36" Root zone watering system		R = Reclaimed cap
		CV-R = Check valve with reclaimed cap

ADDITIONAL OPTIONS (SPECIFY SEPARATELY)

RZWS-SLEEVE = Field installed sleeve made from filter fabric

RZWS-CAP = Replacement cap for 18" and 36" models

RZWS-RCCAP = Reclaimed water replacement cap for 18" and 36" models

RZWS10RCC = Reclaimed water replacement cap for 10" models

Examples:

RZWS-18 - 25 - CV = 18" Root zone watering system at 0.25 GPM, with check valve

RZWS-10 - 50 = 10" Root zone watering system at 0.50 GPM

RZWS-36 - 25 - CV = 36" Root zone watering system at 0.25 GPM, with check valve



ACCESSORIES

ACCESSORIES



ACCESSORIES

ACCESSORIES

HCV

Models

- HC-50F-50F: 1/2" Female inlet x 1/2" Female outlet
- HC-50F-50M: 1/2" Female inlet x 1/2" Male outlet
- HC-75F-75M: 3/4" Female inlet x 3/4" Male outlet

Features

- Adjustment access through top of valve
- Adjusts to compensate for elevational changes up to 32 ft.: Maximum flexibility
- Variety of inlet and outlet options: Reduces need for additional fittings
- Meets schedule 80 specifications: Durable under high pressure



HCV

Overall height: 3"

HUNTER SPIRAL BARB ELBOWS

Models

- HSBE-050: 1/2" male NPT x spiral barb elbow
- HSBE-075: 3/4" male NPT x spiral barb elbow
- HSBE TOOL: Insert tool

Features

- For use with FLEXsg Tubing
- Acetel material for sharp barbs
- Operating pressure up to 80 PSI
- Compatible with FLEXsg and other brands



Spiral Barb Elbows

HSBE-TOOL, HSBE-050, HSBE-075

Pressure loss charts for HCV products are located on page 141.

ACCESSORIES

SJ SWING JOINT

Models

- SJ-506: ½" threaded x 6" length standard
- SJ-506-R: ½" threaded x 6" length retrofit
- SJ-7506: ½" x ¾" threaded x 6" length
- SJ-706: ¾" threaded x 6" length
- SJ-512: ½" threaded x 12" length
- SJ-7512: ½" x ¾" threaded x 12" length
- SJ-712: ¾" threaded x 12" length

Features

- Standard configuration has swivel ells on both ends for maximum versatility
- Retrofit version has a 1¾" hex nut for easy threading into horizontally oriented fittings
- Unique swivel ells can be installed to virtually any configuration, leak free
- Pressure rated to 150 PSI



SJ Swing Joint
6" and 12" links

FLEXsg TUBING

Model

- FLEXsg: 100 ft. roll

Features

- Engineered to resist kinking
- Inside diameter: 0.49"
- Operating pressure: up to 80 PSI
- Linear low-density polyethylene material
- Meets ASTM D2104, D2239, D2737



FLEXsg Tubing
100 ft. roll

Pressure loss charts for SJ products are located on page 141.

TOOLS



Hunter Wrench
P/N 172000



T-Handle Tool
P/N 053191



Rotor Pressure Gauge
P/N 129900
(works with PGP-ADJ only)



Rotor Pitot Gauge and Tube Assembly
P/N 280100



MP Gauge Assembly
P/N MPGAUGE



MP Tool
P/N MPTOOL

ACCESSORIES

TOOLS



Nozzle Insertion Collar
P/N 123200



Hand Pump
P/N 460302



SpotShot Hose-End Nozzle
¾" P/N 160700
1" P/N 160705



Pocket Punch
P/N POCKETPUNCH
(Punches, inserts, and removes emitters)



ST1600 Tool
P/N 517600



Hunter Emitter Multi Tool
P/N HEMT
(Punches pilot holes and pellets, inserts and removes emitters, cuts tubing)

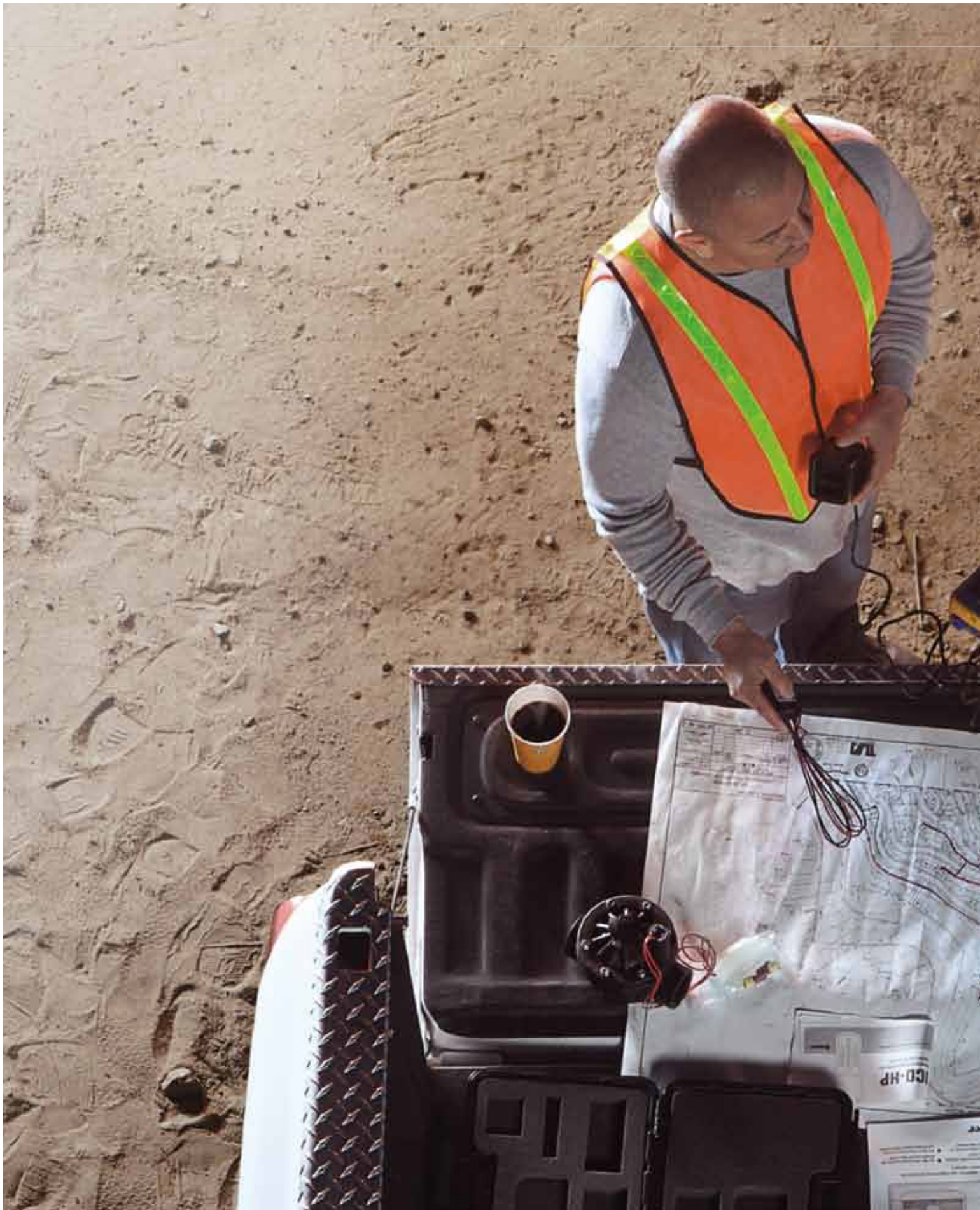

TECHNICAL

TECHNICAL INFORMATION

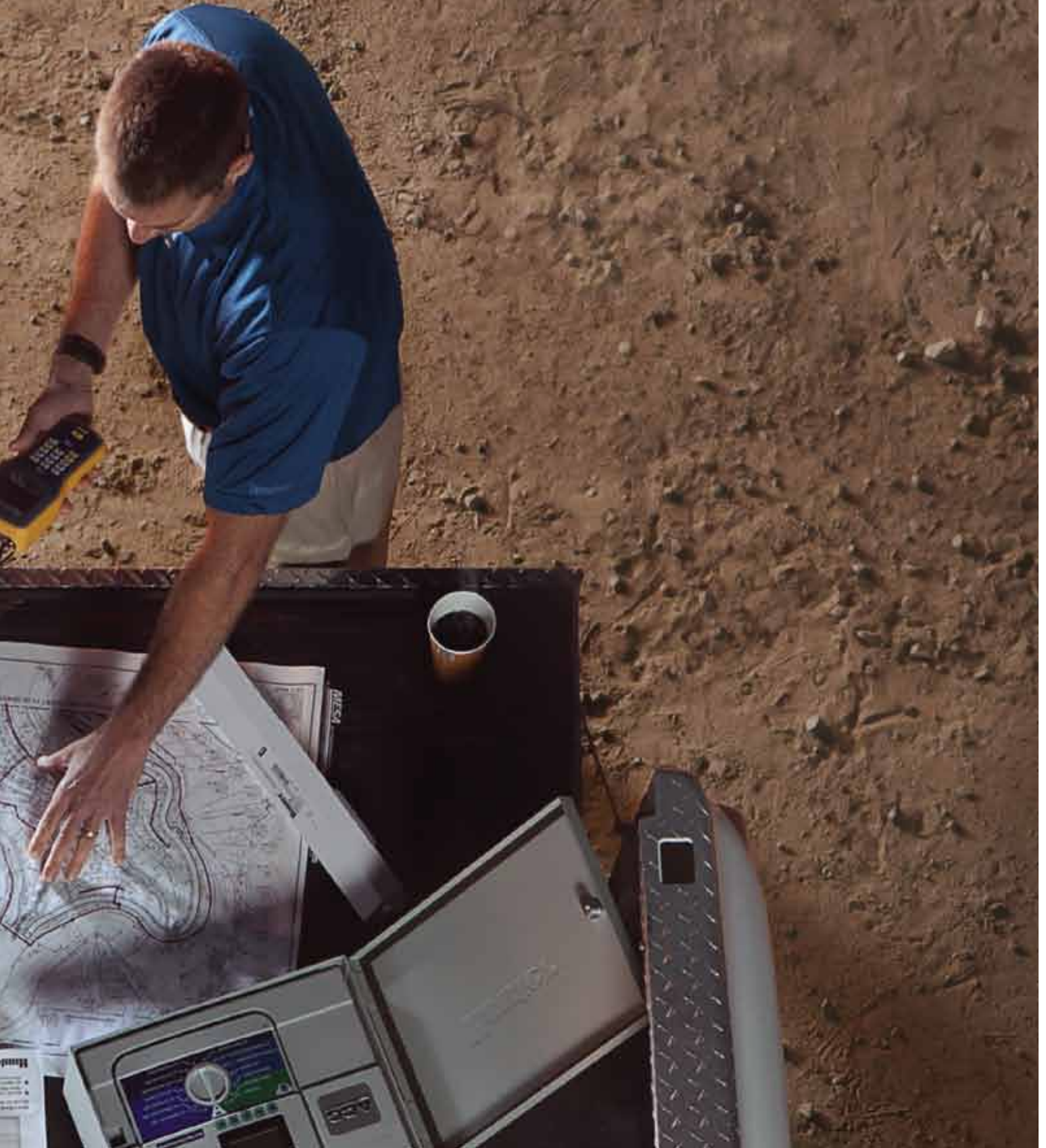

TECHNICAL

REPLACEMENT GUIDE

Bringing together a combination of intelligent design, carefully controlled manufacturing, and regular testing to ensure conformity to the strictest standards, Hunter has been able to create what performance studies have shown to be truly exceptional nozzles. Essentially, we have made the science of developing superior nozzles—and thus, superior sprinklers—look easy. In the process, we have also made it easy for you to determine exactly which of these high performance sprinklers make the appropriate choice for you to install as an alternative to your current product that does not carry the Hunter label. Simply consult our comprehensive replacement guide and you'll quickly see there's a better quality, better performing sprinkler from Hunter that will fit whatever irrigation need you have.

PGJ GEAR DRIVEN ROTARY SPRINKLERS		
To Replace	Use Hunter Nozzle	
RAIN BIRD®	● Red	
3500	0.75	.75
	1	1.0
	1.5	1.5
	2	2.0
	3	3.0
	4	4
T-Bird T-22	.65 (Blue)	.75
	1.0 (Red)	1.0
	1.3 (Black)	1.5
	2.0 (Brown)	2.0
	2.5 (Gray)	2.5
	4.0 (Yellow)	4.0
T-Bird T-30	1.0 (Red)	1.0
	1.3 (Black)	1.5
	2.0 (Brown)	2.0
	2.5 (Gray)	2.5
	4.0 (Yellow)	4.0
	5.0 (Green)	5.0

To Replace	Use Hunter Nozzle	
TORO®	● Red	
300/340	1	.75
Stream Rotor	2	1.5
	3	3.0

To Replace	Use Hunter Nozzle	
NELSON®	● Red	
5500	#51	.75
	#52	1.5
	#53	2.0
	#54	2.5

PGP® GEAR DRIVEN ROTARY SPRINKLERS				
To Replace	Use Hunter Nozzle			
RAIN BIRD®	● Red ● Blue			
Mini-Paw 15103	07 (Black)	6	2.5	
	09 (Green)	7	3.0	
Maxi-Paw 2045	06 (Red)	5	2.0	
	07 (Black)	6	2.5	
	08 (Blue)	8	4.0	
	10 (Yellow)	9	5.0	
	12 (Beige)	10	8.0	
R-50	1.5 (Black)	5	2.0	
	2.0 (Brown)	7	3.0	
	3.0 (Gray)	8	4.0	
	4.0 (Yellow)	9	5.0	
	6.0 (Green)	10	8.0	
T-Bird T-30	1.3 (Black)	4	1.5	
	2.5 (Gray)	6	2.5	
	5.0 (Green)	9	5.0	
5000	1.5	4	1.5	
	2.0	5	2.0	
	3.0	7	3.0	
	4.0	8	4.0	
	6.0	9	5.0	
	8.0	10	8.0	
5505	2	5	2.0	
	3	6	2.5	
	4	7	3.0	
	5	8	4.0	
	6	9	5.0	
	8	10	8.0	
	10	10	8.0	
	12	11	8.0	
15111	10 (5/32" nozzle)	9	5.0	
21A, 27A	10 (5/32" nozzle)	9	5.0	
25	10 (5/32" nozzle)	9	5.0	
31A, 37A	14 (7/32" nozzle)	11	8.0	
35	12 (3/16" nozzle)	10	8.0	

To Replace	Use Hunter Nozzle		
K-RAIN®	● Red ● Blue		
RPS75	0.50	1	--
	0.75	2	--
	1.0	4	1.5
	2.0	6	2.0
	2.5	7	2.5
	3.0	8	3.0
	4.0	9	4.0
	6.0	10	6.0
	8.0	11	8.0

PGP® GEAR DRIVEN ROTARY SPRINKLERS			
To Replace	Use Hunter Nozzle		
TORO®	● Red ● Blue		
300/340	308-XX-02	4	1.5
Stream Rotor	308-XX-03	7	3.0
	316-XX-02	7	3.0
	316-XX-03	10	8.0
XP-300 Series	XP-300-090-07	4	1.5
	180-07	7	3.0
	360-07	10	8.0
	XP-300-090-09	5	2.0
	180-09	8	4.0
	360-09	11	--
	XP-300-090-10	5	2.0
	180-10	9	5.0
	360-10	12	--
Super 600	1.3	4	1.5
	2.5	7	3.0
	5.0	10	8.0
	6.0	10	8.0
Super 700	1.3	3	1.5
	1.5	4	1.5
	2.0	5	2.0
	3.0	7	3.0
	4.5	8	4.0
	6.0	9	5.0
	7.5	10	8.0
	9.0	11	8.0
Super 800	0.50	1	--
	0.75	2	--
	1.0	4	1.5
	2.0	6	2.0
	2.5	7	2.5
	3.0	8	3.0
	4.0	9	4.0
	6.0	10	6.0
	8.0	11	8.0
TR50	1.0	3	--
	1.5	4	1.5
	2.0	5	2.0
	3.0	6	3.0
	4.5	8	4.0
	6.0	9	6.0
	7.5	10	8.0
	9.0	11	8.0

REPLACEMENT GUIDE

PGP® ULTRA / I-20 GEAR DRIVEN ROTARY SPRINKLERS		
To Replace	Use Hunter Nozzle	
RAIN BIRD®	● Blue	
Mini-Paw 15103	07 (Black)	2.5
	09 (Green)	3.0
Maxi-Paw 2045	06 (Red)	2.0
	07 (Black)	2.5
	08 (Blue)	4.0
	10 (Yellow)	5.0
R-50	12 (Beige)	8.0
	1.5 (Black)	2.0
	2.0 (Brown)	3.0
	3.0 (Gray)	4.0
T-Bird T-30	4.0 (Yellow)	5.0
	6.0 (Green)	8.0
	1.3 (Black)	1.5
	2.5 (Gray)	2.5
5000	5.0 (Green)	5.0
	1.5	1.5
	2.0	2.0
5505	3.0	3.0
	4.0	4.0
	6.0	5.0
	8.0	8.0
	8.0	8.0
15111	2	2.0
21A, 27A	3	2.5
25	4	3.0
31A, 37A	5	4.0
35	6	5.0
	8	8.0
	10	8.0
	12	8.0
15111	10 (5/32" nozzle)	5.0
21A, 27A	10 (5/32" nozzle)	5.0
25	10 (5/32" nozzle)	5.0
31A, 37A	14 (7/32" nozzle)	8.0
35	12 (3/16" nozzle)	8.0

To Replace	Use Hunter Nozzle	
K-RAIN®	● Blue	
RPS75	0.50	--
	0.75	--
	1.0	1.5
	2.0	2.0
	2.5	2.5
	3.0	3.0
	4.0	4.0
	6.0	6.0
	8.0	8.0

PGP® ULTRA / I-20 GEAR DRIVEN ROTARY SPRINKLERS		
To Replace	Use Hunter Nozzle	
TORO®	● Blue	
300/340	308-XX-02	1.5
Stream Rotor	308-XX-03	3.0
	316-XX-02	3.0
	316-XX-03	8.0
XP-300 Series	XP-300-090-07	1.5
	180-07	3.0
	360-07	8.0
	XP-300-090-09	2.0
	180-09	4.0
	360-09	--
	XP-300-090-10	2.0
	180-10	5.0
	360-10	--
	Super 600	1.3
	2.5	3.0
	5.0	8.0
	6.0	8.0
Super 700	1.3	1.5
	1.5	1.5
	2.0	2.0
	3.0	3.0
	4.5	4.0
	6.0	5.0
	7.5	8.0
9.0	8.0	
Super 800	0.50	--
	0.75	--
	1.0	1.5
	2.0	2.0
	2.5	2.5
	3.0	3.0
	4.0	4.0
	6.0	6.0
8.0	8.0	
TR50	1.0	--
	1.5	1.5
	2.0	2.0
	3.0	3.0
	4.5	4.0
	6.0	6.0
	7.5	8.0
	9.0	8.0

SPRAY SPRINKLERS		
To Replace	Use Hunter Product	
ANY MFRS NOZZLES	Nozzles	
Nozzles	8' Radius	8A
	10' Radius	10A
	12' Radius	12A
	15' Radius	15A
	17' Radius	17A
Rain Bird 1800	Pro-Spray	
1800 SAM	Pro-Spray-CV	
1800 SAM PRS	Pro-Spray-PRS30-CV	
Uni-Spray	PS Ultra	

REPLACEMENT GUIDE

I-25 GEAR DRIVEN ROTARY SPRINKLER

To Replace RAIN BIRD®	Use Hunter Nozzle		To Replace NELSON®	Use Hunter Nozzle	
FALCON	4 (Black)	4 (Yellow)	7000 & 7500	1	7 (Orange)
	6 (Lt. Blue)	5 (White)		2	8 (Lt. Brown)
	8 (Dk. Green)	7 (Orange)		3	10 (Lt. Green)
	10 (Gray)	8 (Lt. Brown)		4	13 (Lt. Blue)
	12 (Beige)	10 (Lt. Green)		5	15 (Gray)
	14 (Lt. Green)	13 (Lt. Blue)		6	20 (Dk. Brown)
	16 (Dk. Brown)	18 (Red)		7	23 (Dk. Green)
	18 (Dk. Blue)	20 (Dk. Brown)		8	25 (Dk. Blue)
41-51A	18 x 11.5	20 (Dk. Brown)			
41-51A	13 x 11	13 (Lt. Blue)			
47A	16	13 (Lt. Blue)			
37A	14	8 (Lt. Brown)			
7005	4 (Black)	4 (Yellow)	186/187	P-Nozzle	5 (White)
	6 (Lt. Blue)	5 (White)		Q-Nozzle	7 (Orange)
	8 (Dk. Green)	8 (Lt. Brown)		R-Nozzle	13 (Lt. Blue)
	10 (Gray)	10 (Lt. Green)		S-Nozzle	15 (Gray)
	12 (Beige)	13 (Lt. Blue)		T-Nozzle	18 (Red)
	14 (Lt. Green)	15 (Gray)		U-Nozzle	23 (Dk. Green)
	16 (Dk. Brown)	18 (Red)		VS-Nozzle	28 (Black)
	18 (Dk. Blue)	20 (Dk. Brown)		V-Nozzle	28 (Black)
				W-Nozzle	28 (Black)
8005	12 (Beige)	13 (Lt. Blue)			
	14 (Lt. Green)	15 (Gray)			
	16 (Dk. Brown)	18 (Red)			
	18 (Dk. Blue)	20 (Dk. Brown)			
	20 (Red)	23 (Dk. Green)			
	22 (Yellow)	25 (Dk. Blue)			
	24 (Orange)	28 (Black)			

To Replace THOMPSON®

To Replace THOMPSON®	Use Hunter Nozzle	
186/187	P-Nozzle	5 (White)
	Q-Nozzle	7 (Orange)
	R-Nozzle	13 (Lt. Blue)
	S-Nozzle	15 (Gray)
	T-Nozzle	18 (Red)
	U-Nozzle	23 (Dk. Green)
	VS-Nozzle	28 (Black)
	V-Nozzle	28 (Black)
	W-Nozzle	28 (Black)

To Replace SINGLE NOZZLE

To Replace SINGLE NOZZLE	All Impact MFRS	
	5/32"	4 (Yellow)
	1/164"	5 (White)
	3/16"	7 (Orange)
	13/64"	8 (Lt. Brown)
	7/32"	10 (Lt. Green)
	15/64"	13 (Lt. Blue)
	1/4"	15 (Gray)
	17/64"	20 (Dk. Brown)

To Replace TORO®

To Replace TORO®	Use Hunter Nozzle	
2001	6 (Yellow)	7 (Orange)
	9 (Red)	8 (Lt. Brown)
	12 (Brown)	10 (Lt. Green)
	18 (Blue)	18 (Red)
	24 (Green)	25 (Dk. Blue)
640	40	8 (Lt. Brown)
	41	10 (Lt. Green)
	42	13 (Lt. Blue)
	43	15 (Gray)
	44	20 (Dk. Brown)

REPLACEMENT GUIDE

I-40 GEAR DRIVEN ROTARY SPRINKLERS		
To Replace RAIN BIRD®		Use Hunter Nozzle
41-51A	18 x 11.5	23 (Dk. Green)
41-51A	13 x 11	15 (Gray)
47A-SAM	16	13 (Lt. Blue)
37A	14	10 (Lt. Green)
65 SERIES	16	13 (Lt. Blue)
8005	12 (Beige)	10 (Lt. Green)
	14 (Lt. Green)	15 (Gray)
	16 (Dk. Brown)	15 (Gray)
	18 (Dk. Blue)	23 (Dk. Green)
	20 (Red)	25 (Dk. Blue)
TALON	22 (Yellow)	25 (Dk. Blue)
	14	13 (Lt. Blue)
	16	10 (Lt. Green)
	18	23 (Dk. Green)
	20	25 (Dk. Blue)
	22	25 (Dk. Blue)

To Replace TORO®		Use Hunter Nozzle
640	40	8 (Lt. Brown)
	41	10 (Lt. Green)
	42	13 (Lt. Blue)
	43	15 (Gray)
	44	23 (Dk. Green)

To Replace THOMPSON®		Use Hunter Nozzle
186/7	R-Nozzle	13 (Lt. Blue)
	S-Nozzle	15 (Gray)
	T-Nozzle	15 (Gray)
188/9	U-Nozzle	23 (Dk. Green)
	V-Nozzle	25 (Dk. Blue)

To Replace SINGLE NOZZLE		All Impact MFRS
	1564"	10 (Lt. Green)
	14"	13 (Lt. Blue)
	1764"	15 (Gray)
	932"	15 (Gray)

HQ - KEYS				
To Replace RAIN BIRD®	To Replace TORO®	To Replace BUCKNER	To Replace WEST AG/STORM	Use Hunter
33K, 33DK	075-SLK	QB33K07	4C075, C075	HK-33
44K	100-SLK	QB44K10	4C100, C100	HK-44
4K-Acme	100-AK	QB44KAT10	4C100A, C100A	HK-44A
55K-1		QB5RK10	4C101, C101	HK-55

HQ - SWIVELS				
To Replace RAIN BIRD®	To Replace TORO®	To Replace BUCKNER	To Replace WEST AG/STORM	Use Hunter
SH-0	075-75MHS	HS075	4HS-075, HS075	HS-0
SH-1	075-MHS	HS100	4HS-100, HS-100	HS-1
SH-2	100-MHS	HS101	4HS-101, HS-101	HS-2
		HS100BS	4HS-100-BS, HS-100-BS	HS-1-B
		HS101BS	4HS-101-BS, HS-101-BS	HS-2-B

HQ - QUICK COUPLERS				
To Replace RAIN BIRD®	To Replace TORO®	To Replace BUCKNER	To Replace WEST AG/STORM	Use Hunter
3RC	075-SLSC	QB3RC07	4V075-RY, QCV075-R	HQ-3RC
33DRC		QB33RC07	4V133-4A-RY, QCV133-4A-R	HQ-33DRC
33DLRC		QB33LRC07	4V133-4A-RLY, QCV133-4A-RL-2	HQ-33DLRC
33DNP		QB33NP07	4V133-4A-RL-NP, QVC133-4A-N-2	HQ-33DLRC-R
44RC	100-SLSC,	QB44RC10	4V144-RY, QCV-144-R	HQ-44RC
44LRC	100-2SLVC	QB44LRC10	4V144-RLY, QCV-144-RL	HQ-44LRC
44NP	100-SLVLC	QB44NO10	4V144-RL-NP, QCV-144-N	HQ-44LRC-R
	100-2SLLVC	QB44RCATAR10		HQ-44RC-AW
		QB44LRCATAR10		HQ-44LRC-AW
4NP-Acme		QB44NPATAR10		HQ-44LRC-AW-R
5RC	100-ATLVC	QBRB5RC10	4V101-RY, QCV-101-R	HQ-5RC
5LRC		QBRB5LRC10	4V101-RLY, QCV-101-RL	HQ-5LRC
5NP		QBRB5NP10	4V101-RL-NP, QCV-101-N	HQ-5LRC-R
5RC-BSP		QBRB5RC10BS	4V101-RY-BS, QCV-101-R-BS	HQ-5RC-BSP
5LRC-BSP		QBRB5LRC10BS	4V101-RLY-BS, QCV-101-RL-BS	HQ-5LRC-BSP
5NP-BSP		QBRB5NP10BS	4V101-RL-NP-BS, QCV-101-N-BS	HQ-5LRC-BSPR

PRECIPITATION RATES

In this section, the “Sprinkler Spacing Method–Any Arc and Any Spacing” equation is used to calculate precipitation rates. The first set of equations with the ■ shows the precipitation rate for the sprinklers when they are laid out in a square pattern. The next set with the ▲ shows the precipitation rate for the sprinklers laid out in an equilateral triangular spacing pattern. This is the “Sprinkler Spacing Method–Equilateral Triangular Spacing” equation.

WHAT IS “PRECIPITATION RATE”?

If someone said they were caught in a rainstorm that dropped one inch of water in an hour, you would have some idea of how “hard” or “heavily” the rain came down. A rainstorm that covers an area with one inch of water in one hour has a “precipitation rate” of one inch per hour (1 in/hr or 25 mm/hr). Similarly, the precipitation rate is the “speed” at which a sprinkler or an irrigation system applies water.

MATCHED PRECIPITATION RATES

A zone or system in which all the heads have similar precipitation rates is said to have “matched precipitation rates”. Systems that have matched precipitation rates reduce wet and dry spots and excessive run times, which lead to high water consumption and increased costs. Knowing that sprinkler spacing, flow rates, and arcs of coverage affect precipitation rates, a general rule of thumb is: as the spray arc doubles, so should the flow.

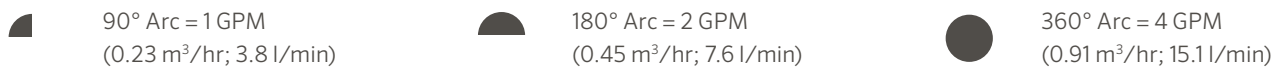

The flow rate of half-circle heads must be two times the flow rate of the quarter-circle heads, and the full-circle heads must have two times the flow rate of the half-circle heads. In the illustration, the same amount of water is applied to each quarter circle area and precipitation is therefore matched.

CALCULATING PRECIPITATION RATES

Depending upon the construction of the irrigation system, the precipitation rate may be calculated by either a “sprinkler spacing” or a “total area” method.

Sprinkler Spacing Method

The precipitation rate should be calculated for each individual zone. If all sprinkler heads on the zone have the same spacing, flow rate, and arc of coverage, use one of the following formulas:

Any Arc and Any Spacing (■):

$$P.R. (mm/hr) = \frac{GPM (for any Arc) \times 34,650}{Degrees of Arc \times Head Spacing (m) \times Row Spacing (m)}$$

$$P.R. (mm/hr) = \frac{m^3/hr (for any Arc) \times 360,000}{Degrees of Arc \times Head Spacing (m) \times Row Spacing (m)}$$

$$P.R. (mm/hr) = \frac{l/min (for any Arc) \times 21,600}{Degrees of Arc \times Head Spacing (m) \times Row Spacing (m)}$$

Equilateral Triangular Spacing (▲):

$$P.R. (mm/hr) = \frac{GPM of 360 Arc \times 96.25}{(Head Spacing)^2 \times 0.866}$$

$$P.R. (mm/hr) = \frac{l/min of 360 Arc \times 60}{(Head Spacing)^2 \times 0.866}$$

$$P.R. (mm/hr) = \frac{m^3/hr \times 1,000}{Total Area}$$

Total Area Method

The precipitation rate for a “system” is the average precipitation rate of all sprinklers in an area, regardless of the spacing, flow rate, or arc for each head. The Total Area Method calculates all the flows of all of the heads in any given area.

$$P.R. (mm/hr) = \frac{Total GPM \times 96.25}{Total Area}$$

$$P.R. (mm/hr) = \frac{l/min \times 60}{Total Area}$$

$$P.R. (mm/hr) = \frac{m^3/hr \times 1,000}{Total Area}$$

SLOPE EQUIVALENTS/IRRIGATION

PERCENT, ANGLE, RATIO

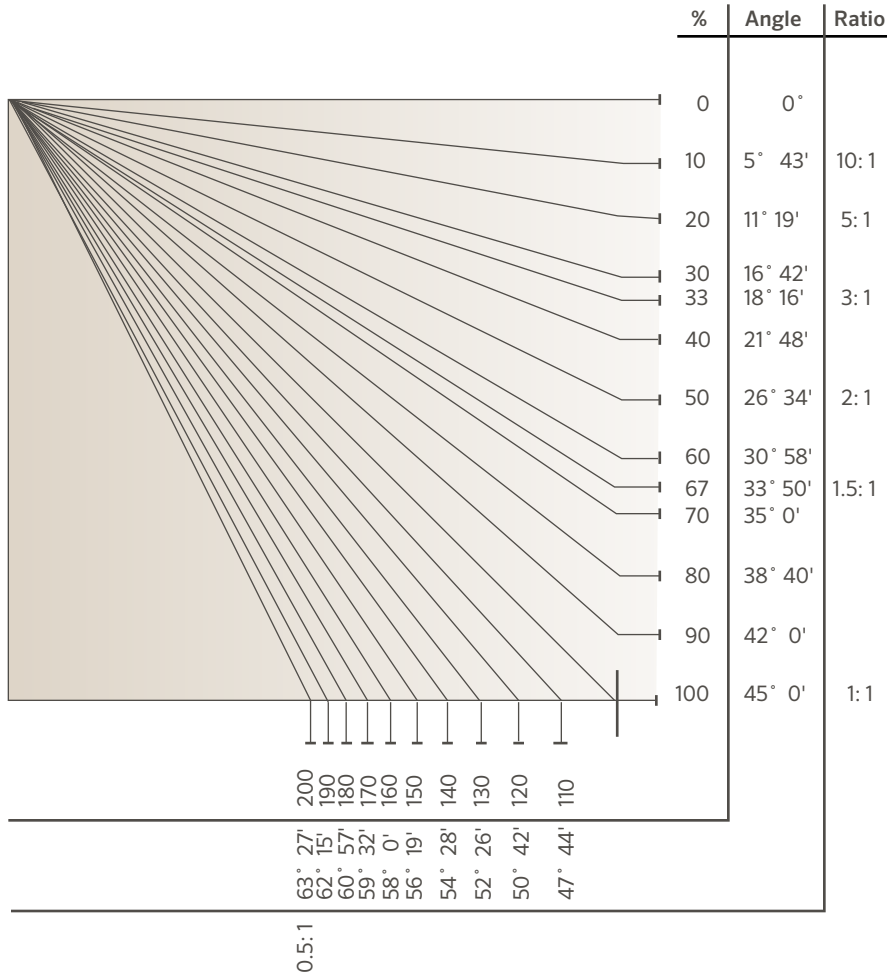

SLOPE IRRIGATION: Maximum precipitation rates for slopes

Soil Texture	0 to 5% Slope		5 to 8% Slope		8 to 12% Slope		12% + Slope	
	Cover	Bare	Cover	Bare	Cover	Bare	Cover	Bare
Coarse sandy soils	2	2	2	1.5	1.5	1	1	0.5
Coarse sandy soils over compact subsoils	1.75	1.5	1.25	1	1	0.75	0.75	0.4
Light sandy loams uniform	1.75	1	1.25	0.8	1	0.6	0.75	0.4
Light sandy loams over compact subsoils	1.25	0.75	1	0.5	0.75	0.4	0.5	0.3
Uniform silt loams	1	0.5	0.8	0.4	0.6	0.3	0.4	0.2
Silt loams over compact subsoil	0.6	0.3	0.5	0.25	0.4	0.15	0.3	0.1
Heavy clay or clay loam	0.2	0.15	0.15	0.1	0.12	0.08	0.1	0.06

Notes:

Maximum precipitation rates for slopes:

The maximum precipitation values listed below are those suggested by the United States Department of Agriculture. The values are average and may vary with respect to actual soil condition and condition of ground cover.

HEIGHT OF SPRAY

The trajectory and spray height of the water stream leaving a sprinkler nozzle is important information when designing and installing irrigation systems.

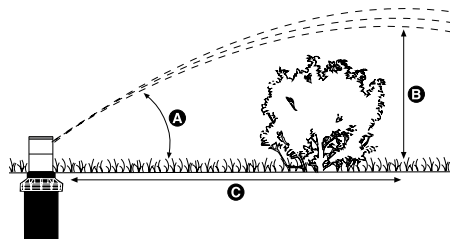

These rotor nozzle trajectory charts are designed to help determine how close a sprinkler can be placed to an object such as a fence or hedge without obstructing the spray pattern. All information shown is at optimum operating pressures.

HUNTER NOZZLE HEIGHT AND TRAJECTORY CHART

Model	Nozzle No.	Pressure (PSI)	Degrees of Trajectory	Max Height of Spray	Distance from Head to Maximum Height (FT.)	
MP ROTATOR	1000	40	20	20"	Varies	
	2000	40	26	45"	Varies	
	3000	40	26	79"	Varies	
	3500	40	26	79"	Varies	
	Corner	40	14	14"	Varies	
	Side Strip	40	16	19"	Varies	
	Left Strip	40	16	18"	Varies	
PGJ	0.75	40	10	2'	4'	
	1.0	40	10	2'	8'	
	1.5	40	10	3'	12'	
	2.0	40	15	5'	16'	
	2.5	40	12	5'	20'	
	3.0	40	15	5'	20'	
	4.0	40	15	5'	22'	
	5.0	40	15	6'	24'	
PGP RED NOZZLES	1	50	26	7'	22'	
	2	50	26	7'	22'	
	3	50	26	8'	23'	
	4	50	26	8'	23'	
	5	50	27	9'	26'	
	6	50	27	10'	28'	
	7	50	26	11'	30'	
	8	50	26	11'	30'	
	9	50	27	12'	32'	
	10	60	25	13'	32'	
	11	60	25	13'	38'	
	12	60	25	13'	40'	
PGP LOW ANGLE GRAY NOZZLES	4	50	15	5'	22'	
	5	50	15	4'	22'	
	6	50	14	4'	22'	
	7	50	14	4'	22'	
	8	50	14	5'	24'	
	9	50	15	5'	26'	
	10	60	15	6'	30'	
	PGP BLUE NOZZLES	1.5	45	25	8'	23'
		2.0	45	25	8'	23'
		2.5	45	25	9'	26'
3.0		45	25	10'	28'	
4.0		45	25	11'	30'	
5.0		45	25	11'	30'	
6.0		55	25	12'	32'	
8.0		55	25	13'	32'	
PGP ULTRA/I-20 DARK BLUE NOZZLES	1.0	50	26	8'	23'	
	1.5	50	26	8'	23'	
	2.0	50	27	9'	26'	
	3.0	50	27	10'	28'	
	3.5	50	26	11'	30'	
	4.0	50	26	11'	30'	
	6.0	50	27	12'	32'	
	8.0	60	25	13'	32'	
PGP ULTRA/I-20 BLUE NOZZLES	1.5	45	25	8'	23'	
	2.0	45	25	8'	23'	
	2.5	45	25	9'	26'	
	3.0	45	25	10'	28'	
	4.0	45	25	11'	30'	
	5.0	45	25	11'	30'	
	6.0	55	25	12'	32'	
	8.0	55	25	13'	32'	

HEIGHT OF SPRAY

HUNTER NOZZLE HEIGHT AND TRAJECTORY CHART

Model	Nozzle No.	Pressure (PSI)	Degrees of Trajectory	Max Height of Spray	Distance from Head to Maximum Height (FT.)
PGP Ultra/I-20 Low Angle Gray Nozzles	2.0LA	50	13	5	22
	2.5LA	50	13	4	22
	3.5LA	50	13	4	22
	4.5LA	50	13	4	22
PGP Ultra/I-20 Short Radius Black Nozzles	0.5	50	15	5	8
	1.0	50	14	6	9
	2.0	50	3	1	6
PGP Ultra/I-20 Short Radius Black Nozzles	0.75	50	22	7	13
	1.5	50	18	7	13
	3.0	50	8	1	6
I-25	4	50	25	9	22
	5	50	25	11	28
	7	50	25	10	28
	8	50	25	11	28
	10	60	25	12	30
	13	60	25	13	31
	15	60	25	12	31
	18	60	25	15	34
	20	70	25	15	35
	23	70	25	16	38
	25	70	25	16	38
I-40	8	50	25	12	32
	10	60	25	14	32
	13	60	25	14	34
	15	60	25	15	42
	23	70	25	17	46
	25	70	25	17	48
I-60 ADS	7	60	20	10	28
	10	60	20	13	38
	13	60	20	13	38
	15	60	20	14	40
	18	60	20	14	40
	20	60	20	15	46
I-60 36S	7	60	20	13	36
	10	60	20	14	40
	13	60	20	14	41
	15	60	20	14	42
	18	60	20	14	43
	20	60	20	17	50
I-90 ADV	33	80	22	15	42
	38	80	22	16	48
	43	80	22	16	48
	48	80	22	17	54
	53	80	22	17	56
	63	80	22	18	64
I-90 36V	33	80	22	17	46
	38	80	22	17	50
	43	80	22	17	54
	48	80	22	17	56
	53	80	22	17	58
	63	80	22	18	62

17 MM PLD CHARTS

PLD APPLICATION RATES

EMITTER FLOW RATE - 1.0 GPH				EMITTER FLOW RATE - 0.6 GPH				EMITTER FLOW RATE - 0.4 GPH			
Row Spacing (in.)	Emitter Spacing (in.)			Row Spacing (in.)	Emitter Spacing (in.)			Row Spacing (in.)	Emitter Spacing (in.)		
	12	18	24		12	18	24		12	18	24
12	1.60	1.07	0.80	12	0.96	0.64	0.48	12	0.64	0.43	0.32
14	1.38	0.92	0.69	14	0.83	0.55	0.41	14	0.55	0.37	0.28
16	1.20	0.80	0.60	16	0.72	0.48	0.36	16	0.48	0.32	0.24
18	1.07	0.71	0.53	18	0.64	0.43	0.32	18	0.43	0.29	0.21
20	0.96	0.64	0.48	20	0.58	0.39	0.29	20	0.39	0.26	0.19
24	0.80	0.53	0.40	24	0.48	0.32	0.24	24	0.32	0.21	0.16

Notes
Application rates in inches per hour

PLD EMITTER LINE MAXIMUM LENGTH CHARTS

EMITTER LINE LENGTH - 0.4 GPH				EMITTER LINE LENGTH - 0.6 GPH				EMITTER LINE LENGTH - 1.0 GPH			
Pressure (PSI)	Emitter Spacing (in.)			Pressure (PSI)	Emitter Spacing (in.)			Pressure (PSI)	Emitter Spacing (in.)		
	12	18	24		12	18	24		12	18	24
15.0	289	401	502	15.0	173	240	300	15.0	126	176	222
20.0	354	494	620	20.0	230	320	402	20.0	169	235	295
25.0	405	563	706	25.0	265	373	471	25.0	197	276	346
30.0	441	621	783	30.0	299	417	523	30.0	218	308	390
35.0	481	671	842	35.0	333	462	580	35.0	240	337	425
40.0	508	719	910	40.0	342	483	611	40.0	263	362	452
45.0	542	755	949	45.0	364	518	657	45.0	271	384	486
50.0	558	784	988	50.0	387	543	685	50.0	288	401	503

PLD FLOW CONVERSION CHARTS

QUICK REFERENCE CHART - GPM PER 100'			
Emitter (GPH)	Emitter Spacing (in.)		
	12	18	24
0.4	0.67	0.44	0.33
0.6	1.00	0.67	0.50
1.0	1.67	1.11	0.83

DRIP CONTROL ZONE KIT CHARTS

ICZ101, PCZ101, ACZ075: Inlet pressure required for designed outlet pressure

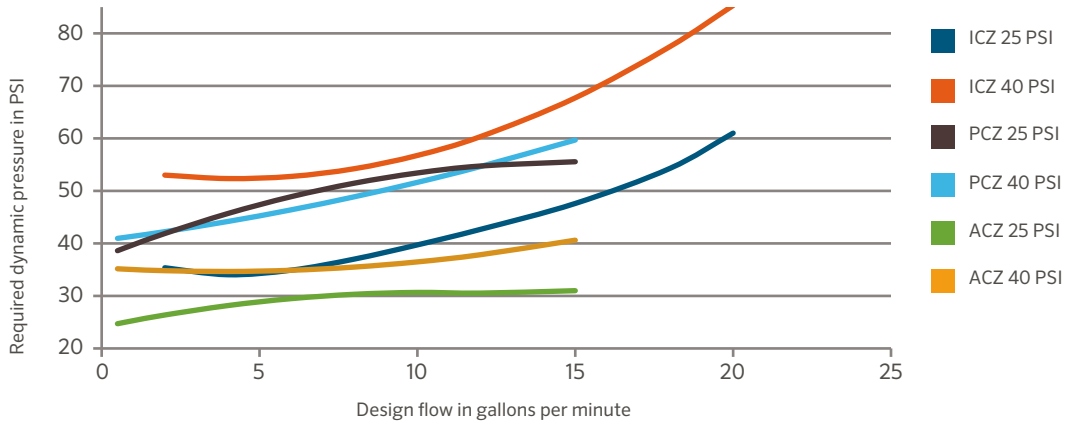

ICZ151: Inlet pressure required for designed outlet pressure

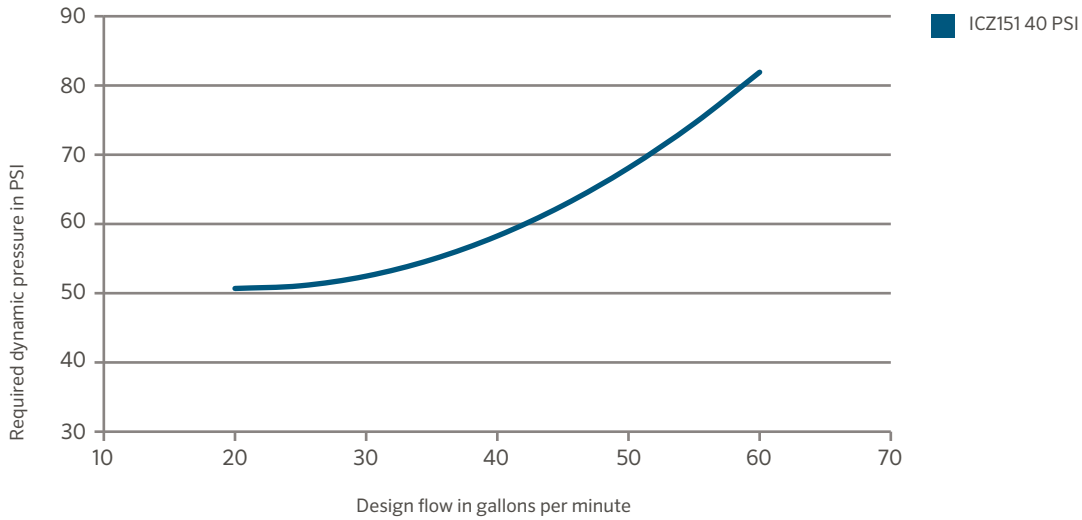

CONVERSION FACTORS

CONVERSION FACTORS			
To Convert	From	To	Multiply By
Area	acres	foot ²	43560
	acres	meter ²	4046.8
	meter ²	foot ²	10.764
	foot ²	inch ²	144
	inch ²	centimeter ²	6.452
	hectares	meter ²	10000
	hectares	acres	2.471
Power	kilowatts	horsepower	1.341
Flow	foot ³ /minute	meter ³ /second	0.0004719
	foot ³ /second	meter ³ /second	0.02832
	yards ³ /minute	meter ³ /second	0.01274
	gallon/minute	meter ³ /hour	0.22716
	gallon/minute	liter/minute	3.7854
	gallon/minute	liter/second	0.06309
	meter ³ /hour	liter/minute	16.645
	meter ³ /hour	liter/second	0.2774
liter/minute	liter/second	60	
Length	foot	inch	12
	inch	centimeter	2.54
	foot	meter	0.30481
	kilometer	miles	0.6214
	miles	foot	5280
	miles	meter	1609.34
	millimeter	inch	0.03937
Pressure	PSI	kilopascals	6.89476
	PSI	bar	0.068948
	bar	kilopascals	100
	PSI	feet of head	2.31
Velocity	feet/second	meter/second	0.3048
Volume	feet ³	gallon	7.481
	feet ³	liter	28.32
	meter ³	feet ³	35.31
	meter ³	yard ³	1.3087
	yard ³	feet ³	27
	yard ³	gallon	202
	acres/feet	foot ³	43,560
	gallon	meter ³	0.003785
	gallon	liter	3.785
	imperial gallon	gallon	1.833

FRICITION LOSS CHARTS

WATER METER PRESSURE LOSS CHART: Typical Pressure Loss (PSI)								
Flow (GPM)	5/8"	3/4"	1"	1 1/2"	2"	3"	4"	Flow (GPM)
1	0.2	0.1						1
2	0.3	0.2						2
3	0.4	0.3						3
4	0.6	0.5	0.1					4
5	0.9	0.6	0.2					5
6	1.3	0.7	0.3					6
7	1.8	0.8	0.4					7
8	2.3	1.0	0.5					8
9	3.0	1.3	0.6					9
10	3.7	1.6	0.7					10
11	4.4	1.9	0.8					11
12	5.1	2.2	0.9					12
13	6.1	2.6	1.0					13
14	7.2	3.1	1.1					14
15	8.3	3.6	1.2					15
16	9.4	4.1	1.4	0.4				16
17	10.7	4.6	1.6	0.5				17
18	12.0	5.2	1.8	0.6				18
19	13.4	5.8	2.0	0.7				19
20	15.0	6.5	2.2	0.8				20
22		7.9	2.8	1.0				22
24		9.5	3.4	1.2				24
26		11.2	4.0	1.4				26
28		13.0	4.6	1.6				28
30		15.0	5.3	1.8	0.7			30
32			6.0	2.1	0.8			32
34			6.9	2.4	0.9			34
36			7.8	2.7	1.0			36
38			8.7	3.0	1.2			38
40			9.6	3.3	1.3			40
42			10.6	3.6	1.4			42
44			11.7	3.9	1.5			44
46			12.8	4.2	1.6			46
48			13.9	4.5	1.7			48
50			15.0	4.9	1.9			50
52				5.3	2.1			52
54				5.7	2.2			54
56				6.2	2.3			56
58				6.7	2.5			58
60				7.2	2.7	1.0		60
65				8.3	3.2	1.1		65
70				9.8	3.7	1.3		70
75				11.3	4.3	1.5		75
80				12.8	4.9	1.6	0.7	80
90				16.1	6.2	2.0	0.8	90
100				20.0	7.8	2.5	0.9	100
110					9.5	2.9	1.0	110
120					11.3	3.4	1.2	120
130					13.0	3.9	1.4	130
140					15.1	4.5	1.6	140
150					17.3	5.1	1.8	150
160					20.0	5.8	2.1	160
170						6.5	2.4	170
180						7.2	2.7	180
190						8.0	3.0	190
200						9.0	3.2	200
220						11.0	3.9	220
240						13.0	4.7	240
260						15.0	5.5	260
280						17.3	6.3	280
300						20.0	7.2	300
350							10.0	350
400							13.0	400
450							16.2	450
500							20.0	500
75% of max meter capacity	15 GPM	22.5 GPM	37.5 GPM	75 GPM	120 GPM	225 GPM	375 GPM	75% of max meter capacity

Notes: Shaded area represents velocities over 5 fps. Use with caution where water hammer is a concern.

FRICITION LOSS CHARTS

TYPE K COPPER TUBING

ASTM B 88 C=40 • PSI loss per 100 ft. of pipe

Nominal Size	½"		⅝"		¾"		1"		1¼"		1½"		2"		2½"		3"	
Pipe ID	0.527		0.652		0.745		0.995		1.245		1.481		1.959		2.435		2.907	
Pipe OD	0.625		0.750		0.875		1.125		1.375		1.625		2.125		2.625		3.125	
Avg. Wall	0.049		0.049		0.065		0.065		0.065		0.072		0.083		0.095		0.109	
Flow (GPM)	Velocity FPS	PSI Loss	Velocity FPS	PSI Loss	Velocity FPS	PSI Loss	Velocity FPS	PSI Loss	Velocity FPS	PSI Loss	Velocity FPS	PSI Loss	Velocity FPS	PSI Loss	Velocity FPS	PSI Loss	Velocity FPS	PSI Loss
1	1.47	1.09	0.96	0.39	0.74	0.20	0.41	0.05	0.26	0.02								
2	2.94	3.94	1.92	1.40	1.47	0.73	0.82	0.18	0.53	0.06								
3	4.41	8.35	2.88	2.97	2.21	1.55	1.24	0.38	0.79	0.13								
4	5.88	14.23	3.84	5.05	2.94	2.64	1.65	0.65	1.05	0.22								
5	7.35	21.51	4.80	7.64	3.68	3.99	2.06	0.98	1.32	0.33								
6	8.81	30.15	5.76	10.70	4.41	5.59	2.47	1.37	1.58	0.46	1.12	0.20						
7	10.28	40.12	6.72	14.24	5.15	7.44	2.88	1.82	1.84	0.61	1.30	0.26						
8	11.75	51.37	7.68	18.24	5.88	9.53	3.30	2.33	2.11	0.78	1.49	0.34						
9	13.22	63.90	8.64	22.68	6.62	11.85	3.71	2.90	2.37	0.97	1.67	0.42						
10	14.69	77.66	9.60	27.57	7.35	14.41	4.12	3.52	2.63	1.18	1.86	0.51						
12			11.52	38.64	8.82	20.20	4.95	4.94	3.16	1.66	2.23	0.71	1.28	0.18				
14			13.44	51.41	10.29	26.87	5.77	6.57	3.69	2.21	2.60	0.95	1.49	0.24				
16			15.36	65.83	11.76	34.41	6.59	8.42	4.21	2.83	2.98	1.22	1.70	0.31				
18			17.28	81.88	13.23	42.80	7.42	10.47	4.74	3.52	3.35	1.51	1.91	0.39				
20					14.70	52.02	8.24	12.72	5.26	4.28	3.72	1.84	2.13	0.47				
22					16.17	62.06	9.07	15.18	5.79	5.10	4.09	2.19	2.34	0.56	1.51	0.19	1.06	0.08
24					17.64	72.91	9.89	17.84	6.32	5.99	4.46	2.58	2.55	0.66	1.65	0.23	1.16	0.10
26							10.71	20.69	6.84	6.95	4.84	2.99	2.76	0.77	1.79	0.27	1.26	0.11
28							11.54	23.73	7.37	7.97	5.21	3.43	2.98	0.88	1.93	0.30	1.35	0.13
30							12.36	26.96	7.90	9.06	5.58	3.89	3.19	1.00	2.06	0.35	1.45	0.15
32							13.19	30.39	8.42	10.21	5.95	4.39	3.40	1.12	2.20	0.39	1.54	0.16
34							14.01	34.00	8.95	11.42	6.32	4.91	3.61	1.26	2.34	0.44	1.64	0.18
36							14.84	37.79	9.48	12.70	6.70	5.46	3.83	1.40	2.48	0.49	1.74	0.20
38							15.66	41.77	10.00	14.04	7.07	6.03	4.04	1.55	2.61	0.54	1.83	0.23
40							16.48	45.94	10.53	15.43	7.44	6.63	4.25	1.70	2.75	0.59	1.93	0.25
42							17.31	50.28	11.06	16.89	7.81	7.26	4.47	1.86	2.89	0.65	2.03	0.27
44									11.58	18.41	8.18	7.91	4.68	2.03	3.03	0.70	2.12	0.30
46									12.11	19.99	8.56	8.59	4.89	2.20	3.17	0.76	2.22	0.32
48									12.63	21.63	8.93	9.30	5.10	2.38	3.30	0.83	2.32	0.35
50									13.16	23.33	9.30	10.03	5.32	2.57	3.44	0.89	2.41	0.38
55									14.48	27.84	10.23	11.96	5.85	3.07	3.78	1.06	2.66	0.45
60									15.79	32.70	11.16	14.05	6.38	3.60	4.13	1.25	2.90	0.53
65									17.11	37.93	12.09	16.30	6.91	4.18	4.47	1.45	3.14	0.61
70									18.43	43.51	13.02	18.70	7.44	4.79	4.82	1.66	3.38	0.70
75											13.95	21.24	7.97	5.45	5.16	1.89	3.62	0.80
80											14.88	23.94	8.51	6.14	5.50	2.13	3.86	0.90
85											15.81	26.79	9.04	6.87	5.85	2.38	4.10	1.01
90											16.74	29.78	9.57	7.63	6.19	2.65	4.35	1.12
95											17.67	32.91	10.10	8.44	6.54	2.93	4.59	1.24
100											18.60	36.19	10.63	9.28	6.88	3.22	4.83	1.36
110													11.69	11.07	7.57	3.84	5.31	1.62
120													12.76	13.01	8.26	4.51	5.79	1.91
130													13.82	15.08	8.95	5.23	6.28	2.21
140													14.88	17.30	9.63	6.00	6.76	2.54
150													15.95	19.66	10.32	6.82	7.24	2.88
160													17.01	22.16	11.01	7.69	7.72	3.25
170													18.07	24.79	11.70	8.60	8.21	3.63
180															12.39	9.56	8.69	4.04
190															13.07	10.57	9.17	4.46
200															13.76	11.62	9.66	4.91
220															15.14	13.87	10.62	5.86
240															16.51	16.29	11.59	6.88
260															17.89	18.90	12.55	7.98
280															19.27	21.68	13.52	9.15
300																	14.48	10.40
320																	15.45	11.72
340																	16.42	13.11
360																	17.38	14.58
380																	18.35	16.11
400																		
420																		
440																		
460																		
480																		
500																		

Notes: Shaded area represents velocities over 7 fps. Use with caution where water hammer is a concern.

FRICITION LOSS CHARTS

TYPE L COPPER TUBING																		
C=140 • PSI loss per 100 ft. of pipe																		
Nominal Size	½"		⅝"		¾"		1"		1¼"		1½"		2"		2½"		3"	
Pipe ID	0.545		0.666		0.785		1.025		1.265		1.505		1.985		2.465		2.945	
Pipe OD	0.625		0.750		0.875		1.125		1.375		1.625		2.125		2.625		3.125	
Avg. Wall	0.040		0.042		0.045		0.050		0.055		0.060		0.070		0.080		0.090	
Flow (GPM)	Velocity FPS	PSI Loss	Velocity FPS	PSI Loss	Velocity FPS	PSI Loss	Velocity FPS	PSI Loss	Velocity FPS	PSI Loss	Velocity FPS	PSI Loss	Velocity FPS	PSI Loss	Velocity FPS	PSI Loss	Velocity FPS	PSI Loss
1	1.37	0.93	0.92	0.35	0.66	0.16	0.39	0.04	0.25	0.02								
2	2.75	3.35	1.84	1.26	1.32	0.57	0.78	0.15	0.51	0.06								
3	4.12	7.09	2.76	2.67	1.99	1.20	1.17	0.33	0.76	0.12								
4	5.49	12.09	3.68	4.56	2.65	2.05	1.55	0.56	1.02	0.20								
5	6.87	18.27	4.60	6.89	3.31	3.09	1.94	0.85	1.27	0.30								
6	8.24	25.61	5.52	9.65	3.97	4.34	2.33	1.18	1.53	0.43	1.08	0.18						
7	9.62	34.07	6.44	12.84	4.63	5.77	2.72	1.58	1.78	0.57	1.26	0.24						
8	10.99	43.63	7.36	16.45	5.30	7.39	3.11	2.02	2.04	0.72	1.44	0.31						
9	12.36	54.26	8.28	20.45	5.96	9.19	3.50	2.51	2.29	0.90	1.62	0.39						
10	13.74	65.95	9.20	24.86	6.62	11.17	3.88	3.05	2.55	1.10	1.80	0.47						
12			11.04	34.85	7.95	15.66	4.66	4.28	3.06	1.54	2.16	0.66	1.24	0.17				
14			12.88	46.36	9.27	20.83	5.44	5.69	3.57	2.04	2.52	0.88	1.45	0.23				
16			14.72	59.37	10.59	26.68	6.21	7.28	4.08	2.62	2.88	1.12	1.66	0.29				
18			16.56	73.84	11.92	33.18	6.99	9.06	4.59	3.25	3.24	1.40	1.86	0.36				
20					13.24	40.33	7.77	11.01	5.10	3.96	3.60	1.70	2.07	0.44				
22					14.57	48.11	8.54	13.14	5.61	4.72	3.96	2.03	2.28	0.53	1.48	0.18	1.03	0.08
24					15.89	56.53	9.32	15.44	6.12	5.55	4.32	2.38	2.49	0.62	1.61	0.22	1.13	0.09
26							10.10	17.90	6.63	6.43	4.68	2.76	2.69	0.72	1.75	0.25	1.22	0.11
28							10.87	20.54	7.14	7.38	5.04	3.17	2.90	0.82	1.88	0.29	1.32	0.12
30							11.65	23.33	7.65	8.38	5.40	3.60	3.11	0.94	2.01	0.33	1.41	0.14
32							12.43	26.30	8.16	9.45	5.76	4.06	3.31	1.05	2.15	0.37	1.51	0.15
34							13.20	29.42	8.67	10.57	6.12	4.54	3.52	1.18	2.28	0.41	1.60	0.17
36							13.98	32.71	9.18	11.75	6.48	5.05	3.73	1.31	2.42	0.46	1.69	0.19
38							14.76	36.15	9.69	12.99	6.84	5.58	3.93	1.45	2.55	0.51	1.79	0.21
40							15.53	39.75	10.20	14.28	7.21	6.13	4.14	1.59	2.69	0.56	1.88	0.23
42							16.31	43.51	10.71	15.63	7.57	6.71	4.35	1.75	2.82	0.61	1.98	0.26
44									11.22	17.04	7.93	7.32	4.56	1.90	2.95	0.66	2.07	0.28
46									11.73	18.50	8.29	7.94	4.76	2.07	3.09	0.72	2.16	0.30
48									12.24	20.02	8.65	8.60	4.97	2.24	3.22	0.78	2.26	0.33
50									12.75	21.59	9.01	9.27	5.18	2.41	3.36	0.84	2.35	0.35
55									14.02	25.76	9.91	11.06	5.70	2.88	3.69	1.00	2.59	0.42
60									15.30	30.26	10.81	13.00	6.21	3.38	4.03	1.18	2.82	0.50
65									16.57	35.10	11.71	15.07	6.73	3.92	4.36	1.37	3.06	0.57
70									17.85	40.26	12.61	17.29	7.25	4.50	4.70	1.57	3.29	0.66
75											13.51	19.65	7.77	5.11	5.04	1.78	3.53	0.75
80											14.41	22.14	8.28	5.76	5.37	2.01	3.76	0.84
85											15.31	24.77	8.80	6.44	5.71	2.25	4.00	0.94
90											16.21	27.54	9.32	7.16	6.04	2.50	4.23	1.05
95											17.11	30.44	9.84	7.91	6.38	2.76	4.47	1.16
100											18.01	33.47	10.35	8.70	6.71	3.03	4.70	1.28
110													11.39	10.38	7.39	3.62	5.17	1.52
120													12.43	12.20	8.06	4.25	5.65	1.79
130													13.46	14.15	8.73	4.93	6.12	2.07
140													14.50	16.23	9.40	5.66	6.59	2.38
150													15.53	18.44	10.07	6.43	7.06	2.70
160													16.57	20.78	10.74	7.24	7.53	3.05
170													17.60	23.25	11.41	8.11	8.00	3.41
180															12.09	9.01	8.47	3.79
190															12.76	9.96	8.94	4.19
200															13.43	10.95	9.41	4.61
220															14.77	13.07	10.35	5.50
240															16.12	15.35	11.29	6.46
260															17.46	17.80	12.23	7.49
280															18.80	20.42	13.17	8.59
300																	14.11	9.76
320																	15.05	11.00
340																	15.99	12.31
360																	16.94	13.69
380																	17.88	15.13
400																		
420																		
440																		
460																		
480																		
500																		

Notes: Shaded area represents velocities over 7 fps. Use with caution where water hammer is a concern.

FRICITION LOSS CHARTS

SCHEDULE 40 STEEL

ASTM-53B C=100 • PSI loss per 100 ft. of pipe

Nominal Size	½"		¾"		1"		1¼"		1½"		2"		2½"		3"		4"	
Pipe ID	0.622		0.824		1.049		1.38		1.610		20.67		2.469		3.068		4.026	
Pipe OD	0.842		1.050		1.315		1.660		1.900		2.375		2.875		3.500		4.500	
Avg. Wall	0.110		0.113		0.133		0.140		0.145		0.154		0.203		0.218		0.237	
Flow (GPM)	Velocity FPS	PSI Loss	Velocity FPS	PSI Loss	Velocity FPS	PSI Loss	Velocity FPS	PSI Loss	Velocity FPS	PSI Loss	Velocity FPS	PSI Loss	Velocity FPS	PSI Loss	Velocity FPS	PSI Loss	Velocity FPS	PSI Loss
1	1.05	0.91	0.60	0.23	0.37	0.07	0.21	0.02	0.16	0.01								
2	2.11	3.28	1.20	0.84	0.74	0.26	0.43	0.07	0.31	0.03								
3	3.16	6.95	1.80	1.77	1.11	0.55	0.64	0.14	0.47	0.07								
4	4.22	11.85	2.40	3.02	1.48	0.93	0.86	0.25	0.63	0.12								
5	5.27	17.91	3.00	4.56	1.85	1.41	1.07	0.37	0.79	0.18								
6	6.33	25.10	3.61	6.39	2.22	1.97	1.29	0.52	0.94	0.25	0.57	0.07						
7	7.38	33.40	4.21	8.50	2.60	2.63	1.50	0.69	1.10	0.33	0.67	0.10						
8	8.44	42.77	4.81	10.88	2.97	3.36	1.71	0.89	1.26	0.42	0.76	0.12						
9	9.49	53.19	5.41	13.54	3.34	4.18	1.93	1.10	1.42	0.52	0.86	0.15						
10	10.55	64.65	6.01	16.45	3.71	5.08	2.14	1.34	1.57	0.63	0.95	0.19						
12	12.65	90.62	7.21	23.06	4.45	7.12	2.57	1.88	1.89	0.89	1.15	0.26	0.80	0.11				
14			8.41	30.68	5.19	9.48	3.00	2.50	2.20	1.18	1.34	0.35	0.94	0.15				
16			9.61	39.29	5.93	12.14	3.43	3.20	2.52	1.51	1.53	0.45	1.07	0.19				
18			10.82	48.87	6.67	15.10	3.86	3.97	2.83	1.88	1.72	0.56	1.20	0.23				
20			12.02	59.40	7.42	18.35	4.28	4.83	3.15	2.28	1.91	0.68	1.34	0.28				
22			13.22	70.87	8.16	21.89	4.71	5.76	3.46	2.72	2.10	0.81	1.47	0.34	0.95	0.12	0.55	0.03
24					8.90	25.72	5.14	6.77	3.78	3.20	2.29	0.95	1.61	0.40	1.04	0.14	0.60	0.04
26					9.64	29.83	5.57	7.85	4.09	3.71	2.48	1.10	1.74	0.46	1.13	0.16	0.65	0.04
28					10.38	34.22	6.00	9.01	4.41	4.25	2.67	1.26	1.87	0.53	1.21	0.18	0.70	0.05
30					11.12	38.88	6.43	10.24	4.72	4.83	2.86	1.43	2.01	0.60	1.30	0.21	0.76	0.06
32					11.86	43.81	6.86	11.54	5.04	5.45	3.06	1.62	2.14	0.68	1.39	0.24	0.81	0.06
34					12.61	49.02	7.28	12.91	5.35	6.10	3.25	1.81	2.28	0.76	1.47	0.26	0.86	0.07
36					13.35	54.49	7.71	14.35	5.67	6.78	3.44	2.01	2.41	0.85	1.56	0.29	0.91	0.08
38							8.14	15.86	5.98	7.49	3.63	2.22	2.54	0.94	1.65	0.33	0.96	0.09
40							8.57	17.44	6.30	8.24	3.82	2.44	2.68	1.03	1.73	0.36	1.01	0.10
42							9.00	19.09	6.61	9.02	4.01	2.67	2.81	1.13	1.82	0.39	1.06	0.10
44							9.43	20.81	6.93	9.83	4.20	2.91	2.94	1.23	1.91	0.43	1.11	0.11
46							9.86	22.59	7.24	10.67	4.39	3.16	3.08	1.33	1.99	0.46	1.16	0.12
48							10.28	24.44	7.56	11.55	4.58	3.42	3.21	1.44	2.08	0.50	1.21	0.13
50							10.71	26.36	7.87	12.45	4.77	3.69	3.35	1.55	2.17	0.54	1.26	0.14
55							11.78	31.45	8.66	14.86	5.25	4.40	3.68	1.85	2.38	0.64	1.38	0.17
60							12.85	36.95	9.44	17.45	5.73	5.17	4.02	2.18	2.60	0.76	1.51	0.20
65							13.93	42.86	10.23	20.24	6.21	6.00	4.35	2.53	2.82	0.88	1.64	0.23
70									11.02	23.22	6.68	6.88	4.69	2.90	3.03	1.01	1.76	0.27
75									11.81	26.39	7.16	7.82	5.02	3.29	3.25	1.14	1.89	0.31
80									12.59	29.74	7.64	8.82	5.35	3.71	3.47	1.29	2.01	0.34
85									13.38	33.27	8.12	9.86	5.69	4.15	3.68	1.44	2.14	0.38
90											8.59	10.96	6.02	4.62	3.90	1.60	2.27	0.43
95											9.07	12.12	6.36	5.10	4.12	1.77	2.39	0.47
100											9.55	13.33	6.69	5.61	4.33	1.95	2.52	0.52
110											10.50	15.90	7.36	6.70	4.77	2.33	2.77	0.62
120											11.46	18.68	8.03	7.87	5.20	2.73	3.02	0.73
130											12.41	21.66	8.70	9.12	5.63	3.17	3.27	0.85
140											13.37	24.85	9.37	10.47	6.07	3.64	3.52	0.97
150													10.04	11.89	6.50	4.13	3.78	1.10
160													10.71	13.40	6.94	4.66	4.03	1.24
170													11.38	15.00	7.37	5.21	4.28	1.39
180													12.05	16.67	7.80	5.79	4.53	1.54
190													12.72	18.43	8.24	6.40	4.78	1.71
200													13.39	20.26	8.67	7.04	5.03	1.88
220															9.54	8.40	5.54	2.24
240															10.40	9.87	6.04	2.63
260															11.27	11.45	6.54	3.05
280															12.14	13.13	7.05	3.50
300															13.00	14.92	7.55	3.98
320															13.87	16.81	8.05	4.48
340																	8.56	5.01
360																	9.06	5.57
380																	9.57	6.16
400																	10.07	6.77
420																	10.57	7.42
440																	11.08	8.08
460																	11.58	8.78
480																	12.08	9.50
500																	12.59	10.24

Notes: Shaded area represents velocities over 7 fps. Use with caution where water hammer is a concern.

FRICITION LOSS CHARTS

CLASS 160 PVC IPS PLASTIC PIPE																		
ASTM D-2241 (1120, 1220) SDR 26 C=150 • PSI loss per 100 ft. of pipe																		
Nominal Size	½"		¾"		1"		1¼"		1½"		2"		2½"		3"		4"	
Avg. ID	0.696		0.910		1.175		1.512		1.734		2.173		2.635		3.21		4.134	
Pipe ID	0.840		1.050		1.315		1.660		1.900		2.375		2.875		3.500		4.500	
Avg. Wall	0.072		0.070		0.070		0.074		0.083		0.101		0.120		0.145		0.183	
Min. Wall	0.062		0.060		0.060		0.064		0.073		0.073		0.110		0.135		0.173	
Flow (GPM)	Velocity FPS	PSI Loss	Velocity FPS	PSI Loss	Velocity FPS	PSI Loss	Velocity FPS	PSI Loss	Velocity FPS	PSI Loss	Velocity FPS	PSI Loss	Velocity FPS	PSI Loss	Velocity FPS	PSI Loss	Velocity FPS	PSI Loss
1	0.84	0.25	0.49	0.07	0.30	0.02	0.18	0.01	0.14	0.00								
2	1.68	0.90	0.99	0.24	0.59	0.07	0.36	0.02	0.27	0.01	0.17	0.00						
3	2.53	1.90	1.48	0.52	0.89	0.15	0.54	0.04	0.41	0.02	0.26	0.01						
4	3.37	3.24	1.97	0.88	1.18	0.25	0.71	0.07	0.54	0.04	0.35	0.01	0.24	0.00				
5	4.21	4.89	2.46	1.33	1.48	0.38	0.89	0.11	0.68	0.06	0.43	0.02	0.29	0.01				
6	5.05	6.86	2.96	1.86	1.77	0.54	1.07	0.16	0.81	0.08	0.52	0.03	0.35	0.01	0.24	0.00		
7	5.90	9.12	3.45	2.47	2.07	0.71	1.25	0.21	0.95	0.11	0.60	0.04	0.41	0.01	0.28	0.01		
8	6.74	11.68	3.94	3.17	2.36	0.91	1.43	0.27	1.09	0.14	0.69	0.05	0.47	0.02	0.32	0.01		
9	7.58	14.53	4.43	3.94	2.66	1.14	1.61	0.33	1.22	0.17	0.78	0.06	0.53	0.02	0.36	0.01		
10	8.42	17.66	4.93	4.79	2.96	1.38	1.78	0.40	1.36	0.21	0.86	0.07	0.59	0.03	0.40	0.01		
12	10.11	24.75	5.91	6.71	3.55	1.94	2.14	0.57	1.63	0.29	1.04	0.10	0.71	0.04	0.48	0.01		
14	11.79	32.93	6.90	8.93	4.14	2.58	2.50	0.76	1.90	0.39	1.21	0.13	0.82	0.05	0.55	0.02		
16	13.48	42.16	7.88	11.44	4.73	3.30	2.86	0.97	2.17	0.50	1.38	0.17	0.94	0.06	0.63	0.02	0.38	0.01
18	15.16	52.44	8.87	14.23	5.32	4.10	3.21	1.20	2.44	0.62	1.56	0.21	1.06	0.08	0.71	0.03	0.43	0.01
20			9.85	17.29	5.91	4.99	3.57	1.46	2.71	0.75	1.73	0.25	1.18	0.10	0.79	0.04	0.48	0.01
22			10.84	20.63	6.50	5.95	3.93	1.74	2.99	0.90	1.90	0.30	1.29	0.12	0.87	0.04	0.53	0.01
24			11.82	24.24	7.09	6.99	4.28	2.05	3.26	1.05	2.07	0.35	1.41	0.14	0.95	0.05	0.57	0.02
26			12.81	28.11	7.68	8.11	4.64	2.38	3.53	1.22	2.25	0.41	1.53	0.16	1.03	0.06	0.62	0.02
28			13.80	32.25	8.27	9.30	5.00	2.73	3.80	1.40	2.42	0.47	1.65	0.18	1.11	0.07	0.67	0.02
30			14.78	36.64	8.87	10.57	5.35	3.10	4.07	1.59	2.59	0.53	1.76	0.21	1.19	0.08	0.72	0.02
32					9.46	11.91	5.71	3.49	4.34	1.79	2.76	0.60	1.88	0.23	1.27	0.09	0.76	0.03
34					10.05	13.32	6.07	3.91	4.61	2.01	2.94	0.67	2.00	0.26	1.35	0.10	0.81	0.03
36					10.64	14.81	6.42	4.34	4.88	2.23	3.11	0.74	2.12	0.29	1.43	0.11	0.86	0.03
38					11.23	16.37	6.78	4.80	5.16	2.46	3.28	0.82	2.23	0.32	1.50	0.12	0.91	0.04
40					11.82	18.00	7.14	5.28	5.43	2.71	3.46	0.90	2.35	0.35	1.58	0.14	0.95	0.04
42					12.41	19.70	7.50	5.78	5.70	2.97	3.63	0.99	2.47	0.39	1.66	0.15	1.00	0.04
44					13.00	21.47	7.85	6.30	5.97	3.23	3.80	1.08	2.59	0.42	1.74	0.16	1.05	0.05
46					13.59	23.32	8.21	6.84	6.24	3.51	3.97	1.17	2.70	0.46	1.82	0.18	1.10	0.05
48					14.18	25.23	8.57	7.40	6.51	3.80	4.15	1.27	2.82	0.50	1.90	0.19	1.15	0.06
50					14.78	27.21	8.92	7.98	6.78	4.10	4.32	1.37	2.94	0.53	1.98	0.20	1.19	0.06
55							9.82	9.52	7.46	4.89	4.75	1.63	3.23	0.64	2.18	0.24	1.31	0.07
60							10.71	11.18	8.14	5.74	5.18	1.91	3.53	0.75	2.38	0.29	1.43	0.08
65							11.60	12.97	8.82	6.66	5.62	2.22	3.82	0.87	2.57	0.33	1.55	0.10
70							12.49	14.88	9.50	7.64	6.05	2.55	4.11	1.00	2.77	0.38	1.67	0.11
75							13.38	16.90	10.18	8.68	6.48	2.89	4.41	1.13	2.97	0.43	1.79	0.13
80							14.28	19.05	10.86	9.78	6.91	3.26	4.70	1.28	3.17	0.49	1.91	0.14
85									11.53	10.94	7.34	3.65	4.99	1.43	3.37	0.55	2.03	0.16
90									12.21	12.16	7.78	4.06	5.29	1.59	3.56	0.61	2.15	0.18
95									12.89	13.45	8.21	4.48	5.58	1.76	3.76	0.67	2.27	0.20
100									13.57	14.79	8.64	4.93	5.88	1.93	3.96	0.74	2.39	0.22
110									14.93	17.64	9.50	5.88	6.46	2.30	4.36	0.88	2.63	0.26
120											10.37	6.91	7.05	2.71	4.75	1.04	2.86	0.30
130											11.23	8.02	7.64	3.14	5.15	1.20	3.10	0.35
140											12.10	9.20	8.23	3.60	5.54	1.38	3.34	0.40
150											12.96	10.45	8.81	4.09	5.94	1.57	3.58	0.46
160											13.82	11.77	9.40	4.61	6.34	1.76	3.82	0.52
170											14.69	13.17	9.99	5.16	6.73	1.97	4.06	0.58
180													10.58	5.73	7.13	2.19	4.30	0.64
190													11.16	6.34	7.52	2.42	4.54	0.71
200													11.75	6.97	7.92	2.67	4.77	0.78
220													12.93	8.31	8.71	3.18	5.25	0.93
240													14.10	9.77	9.50	3.74	5.73	1.09
260															10.29	4.33	6.21	1.27
280															11.09	4.97	6.68	1.45
300															11.88	5.65	7.16	1.65
320															12.67	6.37	7.64	1.86
340															13.46	7.12	8.12	2.08
360															14.25	7.92	8.59	2.31
380																	9.07	2.56
400																	9.55	2.81
420																	10.03	3.08
440																	10.50	3.35
460																	10.98	3.64
480																	11.46	3.94
500																	11.94	4.25

Notes: Shaded area represents velocities over 5 fps. Use with caution where water hammer is a concern.

FRICITION LOSS CHARTS

CLASS 200 PVC IPS PLASTIC PIPE

ASTM D-2241 (1120, 1220) SDR 21 C=150 • PSI loss per 100 ft. of pipe

Nominal Size	Class 315: ½"		¾"		1"		1¼"		1½"		2"		2½"		3"		4"		6"	
Avg. ID	0.696		0.910		1.169		1.482		1.700		2.129		2.581		3.146		4.046		5.955	
Pipe OD	0.840		1.050		1.315		1.660		1.900		2.375		2.875		3.500		4.500		6.625	
Avg. Wall	0.072		0.070		0.073		0.089		0.100		0.123		0.147		0.177		0.227		0.335	
Min. Wall	0.062		0.060		0.063		0.079		0.090		0.113		0.137		0.167		0.214		0.316	
Flow (GPM)	Velocity FPS	PSI Loss	Velocity FPS	PSI Loss	Velocity FPS	PSI Loss	Velocity FPS	PSI Loss	Velocity FPS	PSI Loss	Velocity FPS	PSI Loss	Velocity FPS	PSI Loss	Velocity FPS	PSI Loss	Velocity FPS	PSI Loss	Velocity FPS	PSI Loss
1	0.84	0.25	0.49	0.07	0.30	0.02	0.19	0.01	0.14	0.00										
2	1.68	0.90	0.99	0.24	0.60	0.07	0.37	0.02	0.28	0.01	0.18	0.00								
3	2.53	1.90	1.48	0.52	0.90	0.15	0.56	0.05	0.42	0.02	0.27	0.01								
4	3.37	3.24	1.97	0.88	1.19	0.26	0.74	0.08	0.56	0.04	0.36	0.01	0.24	0.01						
5	4.21	4.89	2.46	1.33	1.49	0.39	0.93	0.12	0.71	0.06	0.45	0.02	0.31	0.01						
6	5.05	6.86	2.96	1.86	1.79	0.55	1.11	0.17	0.85	0.09	0.54	0.03	0.37	0.01	0.25	0.00				
7	5.90	9.12	3.45	2.47	2.09	0.73	1.30	0.23	0.99	0.12	0.63	0.04	0.43	0.02	0.29	0.01				
8	6.74	11.68	3.94	3.17	2.39	0.94	1.49	0.30	1.13	0.15	0.72	0.05	0.49	0.02	0.33	0.01				
9	7.58	14.53	4.43	3.94	2.69	1.17	1.67	0.37	1.27	0.19	0.81	0.06	0.55	0.02	0.37	0.01				
10	8.42	17.66	4.93	4.79	2.99	1.42	1.86	0.45	1.41	0.23	0.90	0.08	0.61	0.03	0.41	0.01				
12	10.11	24.75	5.91	6.71	3.58	1.98	2.23	0.63	1.69	0.32	1.08	0.11	0.73	0.04	0.49	0.02				
14	11.79	32.93	6.90	8.93	4.18	2.64	2.60	0.83	1.98	0.43	1.26	0.14	0.86	0.06	0.58	0.02				
16	13.48	42.16	7.88	11.44	4.78	3.38	2.97	1.07	2.26	0.55	1.44	0.18	0.98	0.07	0.66	0.03	0.40	0.01		
18	15.16	52.44	8.87	14.23	5.37	4.21	3.34	1.33	2.54	0.68	1.62	0.23	1.10	0.09	0.74	0.03	0.45	0.01		
20			9.85	17.29	5.97	5.11	3.72	1.61	2.82	0.83	1.80	0.28	1.22	0.11	0.82	0.04	0.50	0.01		
22			10.84	20.63	6.57	6.10	4.09	1.92	3.11	0.99	1.98	0.33	1.35	0.13	0.91	0.05	0.55	0.01		
24			11.82	24.24	7.17	7.17	4.46	2.26	3.39	1.16	2.16	0.39	1.47	0.15	0.99	0.06	0.60	0.02		
26			12.81	28.11	7.76	8.31	4.83	2.62	3.67	1.34	2.34	0.45	1.59	0.18	1.07	0.07	0.65	0.02		
28			13.80	32.25	8.36	9.53	5.20	3.01	3.95	1.54	2.52	0.52	1.71	0.20	1.15	0.08	0.70	0.02		
30			14.78	36.64	8.96	10.83	5.57	3.41	4.24	1.75	2.70	0.59	1.84	0.23	1.24	0.09	0.75	0.03		
32			9.55	12.21	5.94	3.85	4.52	1.97	2.88	0.66	1.96	0.26	1.32	0.10	0.80	0.03	0.37	0.00		
34			10.15	13.66	6.32	4.31	4.80	2.21	3.06	0.74	2.08	0.29	1.40	0.11	0.85	0.03	0.39	0.00		
36			10.75	15.18	6.69	4.79	5.08	2.45	3.24	0.82	2.20	0.32	1.48	0.12	0.90	0.04	0.41	0.01		
38			11.35	16.78	7.06	5.29	5.36	2.71	3.42	0.91	2.33	0.36	1.57	0.14	0.95	0.04	0.44	0.01		
40			11.94	18.45	7.43	5.82	5.65	2.98	3.60	1.00	2.45	0.39	1.65	0.15	1.00	0.04	0.46	0.01		
42			12.54	20.20	7.80	6.37	5.93	3.27	3.78	1.09	2.57	0.43	1.73	0.16	1.05	0.05	0.48	0.01		
44			13.14	22.02	8.17	6.94	6.21	3.56	3.96	1.19	2.69	0.47	1.81	0.18	1.10	0.05	0.51	0.01		
46			13.73	23.91	8.55	7.54	6.49	3.86	4.14	1.29	2.82	0.51	1.90	0.19	1.15	0.06	0.53	0.01		
48			14.33	25.87	8.92	8.15	6.78	4.18	4.32	1.40	2.94	0.55	1.98	0.21	1.20	0.06	0.55	0.01		
50			14.93	27.90	9.29	8.79	7.06	4.51	4.50	1.51	3.06	0.59	2.06	0.23	1.25	0.07	0.58	0.01		
55					10.22	10.49	7.76	5.38	4.95	1.80	3.37	0.71	2.27	0.27	1.37	0.08	0.63	0.01		
60					11.15	12.33	8.47	6.32	5.40	2.11	3.67	0.83	2.47	0.32	1.50	0.09	0.69	0.01		
65					12.07	14.30	9.18	7.33	5.85	2.45	3.98	0.96	2.68	0.37	1.62	0.11	0.75	0.02		
70					13.00	16.40	9.88	8.41	6.30	2.81	4.29	1.10	2.89	0.42	1.74	0.12	0.81	0.02		
75					13.93	18.63	10.59	9.56	6.75	3.20	4.59	1.25	3.09	0.48	1.87	0.14	0.86	0.02		
80					14.86	21.00	11.29	10.77	7.20	3.60	4.90	1.41	3.30	0.54	1.99	0.16	0.92	0.02		
85							12.00	12.05	7.65	4.03	5.21	1.58	3.50	0.60	2.12	0.18	0.98	0.03		
90							12.71	13.40	8.10	4.48	5.51	1.76	3.71	0.67	2.24	0.20	1.04	0.03		
95							13.41	14.81	8.55	4.95	5.82	1.94	3.92	0.74	2.37	0.22	1.09	0.03		
100							14.12	16.28	9.00	5.45	6.12	2.13	4.12	0.81	2.49	0.24	1.15	0.04		
110									9.90	6.50	6.74	2.55	4.53	0.97	2.74	0.29	1.27	0.04		
120									10.80	7.63	7.35	2.99	4.95	1.14	2.99	0.34	1.38	0.05		
130									11.70	8.85	7.96	3.47	5.36	1.32	3.24	0.39	1.50	0.06		
140									12.60	10.16	8.57	3.98	5.77	1.52	3.49	0.45	1.61	0.07		
150									13.50	11.54	9.19	4.52	6.18	1.73	3.74	0.51	1.73	0.08		
160									14.40	13.01	9.80	5.10	6.60	1.95	3.99	0.57	1.84	0.09		
170											10.41	5.70	7.01	2.18	4.24	0.64	1.96	0.10		
180											11.02	6.34	7.42	2.42	4.49	0.71	2.07	0.11		
190											11.64	7.01	7.83	2.67	4.74	0.79	2.19	0.12		
200											12.25	7.71	8.24	2.94	4.98	0.86	2.30	0.13		
220											13.47	9.19	9.07	3.51	5.48	1.03	2.53	0.16		
240											14.70	10.80	9.89	4.12	5.98	1.21	2.76	0.18		
260													10.72	4.78	6.48	1.41	2.99	0.21		
280													11.54	5.48	6.98	1.61	3.22	0.25		
300													12.37	6.23	7.48	1.83	3.45	0.28		
320													13.19	7.02	7.98	2.06	3.68	0.31		
340													14.02	7.86	8.47	2.31	3.91	0.35		
360													14.84	8.73	8.97	2.57	4.14	0.39		
380															9.47	2.84	4.37	0.43		
400															9.97	3.12	4.60	0.48		
420															10.47	3.42	4.83	0.52		
440															10.97	3.72	5.06	0.57		
460															11.46	4.04	5.29	0.62		
480															11.96	4.37	5.52	0.67		
500															12.46	4.72	5.75	0.72		

Notes: Shaded area represents velocities over 5 fps. Use with caution where water hammer is a concern.

FRICITION LOSS CHARTS

CLASS 315 PVC IPS PLASTIC PIPE																				
ASTM D-2241 (1120, 1220) SDR 13.5 C=40 • PSI loss per 100 ft. of pipe																				
Nominal Size	½"		¾"		1"		1¼"		1½"		2"		2½"		3"		4"		6"	
Avg. ID	0.696		0.874		1.101		1.394		1.598		1.983		2.423		2.948		3.794		5.583	
Pipe ID	0.840		1.050		1.315		1.660		1.900		2.375		2.875		3.500		4.500		6.625	
Avg. Wall	0.072		0.088		0.107		0.133		0.151		0.196		0.226		0.353		0.353		0.521	
Min. Wall	0.062		0.078		0.097		0.123		0.141		0.176		0.213		0.333		0.33		0.491	
Flow (GPM)	Velocity FPS	PSI Loss	Velocity FPS	PSI Loss	Velocity FPS	PSI Loss	Velocity FPS	PSI Loss	Velocity FPS	PSI Loss	Velocity FPS	PSI Loss	Velocity FPS	PSI Loss	Velocity FPS	PSI Loss	Velocity FPS	PSI Loss	Velocity FPS	PSI Loss
1	0.84	0.25	0.53	0.08	0.34	0.03	0.21	0.01	0.16	0.00										
2	1.68	0.90	1.07	0.30	0.67	0.10	0.42	0.03	0.32	0.02	0.21	0.01								
3	2.53	1.90	1.60	0.63	1.01	0.20	0.63	0.06	0.48	0.03	0.31	0.01								
4	3.37	3.24	2.14	1.07	1.35	0.35	0.84	0.11	0.64	0.06	0.42	0.02	0.28	0.01						
5	4.21	4.89	2.67	1.61	1.68	0.53	1.05	0.17	0.80	0.09	0.52	0.03	0.35	0.01						
6	5.05	6.86	3.20	2.26	2.02	0.74	1.26	0.23	0.96	0.12	0.62	0.04	0.42	0.02	0.28	0.01				
7	5.90	9.12	3.74	3.01	2.36	0.98	1.47	0.31	1.12	0.16	0.73	0.06	0.49	0.02	0.33	0.01				
8	6.74	11.68	4.27	3.86	2.69	1.25	1.68	0.40	1.28	0.20	0.83	0.07	0.56	0.03	0.38	0.01				
9	7.58	14.53	4.81	4.80	3.03	1.56	1.89	0.49	1.44	0.25	0.93	0.09	0.63	0.03	0.42	0.01				
10	8.42	17.66	5.34	5.83	3.37	1.90	2.10	0.60	1.60	0.31	1.04	0.11	0.69	0.04	0.47	0.02				
12	10.11	24.75	6.41	8.17	4.04	2.66	2.52	0.84	1.92	0.43	1.25	0.15	0.83	0.06	0.56	0.02				
14	11.79	32.93	7.48	10.87	4.71	3.53	2.94	1.12	2.24	0.58	1.45	0.20	0.97	0.08	0.66	0.03				
16	13.48	42.16	8.55	13.92	5.39	4.53	3.36	1.44	2.56	0.74	1.66	0.26	1.11	0.10	0.75	0.04	0.45	0.01		
18	15.16	52.44	9.61	17.32	6.06	5.63	3.78	1.79	2.88	0.92	1.87	0.32	1.25	0.12	0.85	0.05	0.51	0.01		
20			10.68	21.05	6.73	6.84	4.20	2.17	3.20	1.12	2.08	0.39	1.39	0.15	0.94	0.06	0.57	0.02		
22			11.75	25.11	7.40	8.16	4.62	2.59	3.52	1.33	2.28	0.47	1.53	0.18	1.03	0.07	0.62	0.02		
24			12.82	29.50	8.08	9.59	5.04	3.04	3.83	1.57	2.49	0.55	1.67	0.21	1.13	0.08	0.68	0.02		
26			13.89	34.21	8.75	11.12	5.46	3.53	4.15	1.82	2.70	0.64	1.81	0.24	1.22	0.09	0.74	0.03		
28			14.96	39.25	9.42	12.76	5.88	4.05	4.47	2.08	2.91	0.73	1.95	0.27	1.31	0.11	0.79	0.03		
30			16.02	44.60	10.10	14.50	6.30	4.60	4.79	2.37	3.11	0.83	2.08	0.31	1.41	0.12	0.85	0.04		
32					10.77	16.34	6.72	5.18	5.11	2.67	3.32	0.93	2.22	0.35	1.50	0.14	0.91	0.04	0.42	0.01
34					11.44	18.28	7.14	5.80	5.43	2.98	3.53	1.04	2.36	0.39	1.60	0.15	0.96	0.04	0.45	0.01
36					12.12	20.32	7.56	6.45	5.75	3.32	3.74	1.16	2.50	0.44	1.69	0.17	1.02	0.05	0.47	0.01
38					12.79	22.46	7.98	7.13	6.07	3.67	3.94	1.28	2.64	0.48	1.78	0.19	1.08	0.05	0.50	0.01
40					13.46	24.70	8.40	7.84	6.39	4.03	4.15	1.41	2.78	0.53	1.88	0.20	1.13	0.06	0.52	0.01
42					14.14	27.04	8.82	8.58	6.71	4.41	4.36	1.54	2.92	0.58	1.97	0.22	1.19	0.07	0.55	0.01
44					14.81	29.47	9.24	9.35	7.03	4.81	4.57	1.68	3.06	0.63	2.07	0.24	1.25	0.07	0.58	0.01
46					15.48	32.00	9.66	10.15	7.35	5.22	4.77	1.83	3.20	0.69	2.16	0.27	1.30	0.08	0.60	0.01
48					16.16	34.62	10.08	10.98	7.67	5.65	4.98	1.98	3.34	0.75	2.25	0.29	1.36	0.08	0.63	0.01
50					16.83	37.34	10.50	11.85	7.99	6.09	5.19	2.13	3.47	0.80	2.35	0.31	1.42	0.09	0.65	0.01
55							11.55	14.13	8.79	7.27	5.71	2.54	3.82	0.96	2.58	0.37	1.56	0.11	0.72	0.02
60							12.60	16.60	9.59	8.54	6.23	2.99	4.17	1.13	2.82	0.43	1.70	0.13	0.79	0.02
65							13.65	19.26	10.39	9.91	6.74	3.47	4.52	1.31	3.05	0.50	1.84	0.15	0.85	0.02
70							14.70	22.09	11.18	11.37	7.26	3.98	4.86	1.50	3.29	0.58	1.98	0.17	0.92	0.03
75							15.75	25.10	11.98	12.91	7.78	4.52	5.21	1.70	3.52	0.66	2.13	0.19	0.98	0.03
80							16.80	28.29	12.78	14.55	8.30	5.09	5.56	1.92	3.76	0.74	2.27	0.22	1.05	0.03
85									13.58	16.28	8.82	5.70	5.91	2.15	3.99	0.83	2.41	0.24	1.11	0.04
90									14.38	18.01	9.34	6.33	6.25	2.39	4.23	0.92	2.55	0.27	1.18	0.04
95									15.18	20.01	9.86	7.00	6.60	2.64	4.46	1.02	2.69	0.30	1.24	0.05
100									15.98	22.00	10.38	7.70	6.95	2.90	4.69	1.12	2.83	0.33	1.31	0.05
110											11.41	9.18	7.64	3.46	5.16	1.33	3.12	0.39	1.44	0.06
120											12.45	10.79	8.34	4.07	5.63	1.57	3.40	0.46	1.57	0.07
130											13.49	12.51	9.03	4.72	6.10	1.82	3.68	0.53	1.70	0.08
140											14.53	14.35	9.73	5.41	6.57	2.08	3.97	0.61	1.83	0.09
150											15.56	16.31	10.42	6.15	7.04	2.37	4.25	0.69	1.96	0.11
160											16.60	18.38	11.12	6.93	7.51	2.67	4.54	0.78	2.09	0.12
170													11.81	7.76	7.98	2.99	4.82	0.87	2.23	0.13
180													12.51	8.62	8.45	3.32	5.10	0.97	2.36	0.15
190													13.20	9.53	8.92	3.67	5.39	1.08	2.49	0.16
200													13.90	10.48	9.39	4.03	5.67	1.18	2.62	0.18
220													15.29	12.50	10.33	4.81	6.24	1.41	2.88	0.22
240													16.68	14.69	11.27	5.66	6.80	1.66	3.14	0.25
260															12.21	6.56	7.37	1.92	3.40	0.29
280															13.15	7.52	7.94	2.20	3.67	0.34
300															14.08	8.55	8.50	2.50	3.93	0.38
320															15.02	9.64	9.07	2.82	4.19	0.43
340															15.96	10.78	9.64	3.16	4.45	0.48
360															16.90	11.98	10.20	3.51	4.71	0.54
380																	10.77	3.88	4.97	0.59
400																	11.34	4.27	5.24	0.65
420																	11.90	4.67	5.50	0.71
440																	12.47	5.09	5.76	0.78
460																	13.04	5.53	6.02	0.84
480																	13.61	5.98	6.28	0.91
500																	14.17	6.45	6.54	0.98

Notes: Shaded area represents velocities over 5 fps. Use with caution where water hammer is a concern.

FRICITION LOSS CHARTS

SCHEDULE 40 PVC IPS PLASTIC PIPE

ASTM D-1785 (1120, 1220) C=150 • PSI loss per 100 ft. of pipe

Nominal Size	½"		¾"		1"		1¼"		1½"		2"		2½"		3"		4"		5"	
Avg. ID	0.602		0.804		1.029		1.360		1.590		20.47		2.445		3.042		3.998		6.031	
Pipe ID	0.840		1.050		1.315		1.660		1.900		2.375		2.875		3.500		4.500		6.625	
Avg. Wall	0.119		0.123		0.143		0.150		0.155		0.164		0.215		0.229		0.251		0.297	
Min. Wall	0.109		0.113		0.133		0.140		0.145		0.154		0.203		0.216		0.237		0.280	
Flow (GPM)	Velocity FPS	PSI Loss	Velocity FPS	PSI Loss	Velocity FPS	PSI Loss	Velocity FPS	PSI Loss	Velocity FPS	PSI Loss	Velocity FPS	PSI Loss	Velocity FPS	PSI Loss	Velocity FPS	PSI Loss	Velocity FPS	PSI Loss	Velocity FPS	PSI Loss
1	1.13	0.50	0.63	0.12	0.39	0.04	0.22	0.01	0.16	0.00										
2	2.25	1.82	1.26	0.44	0.77	0.13	0.44	0.03	0.32	0.02	0.19	0.00								
3	3.38	3.85	1.89	0.94	1.16	0.28	0.66	0.07	0.48	0.03	0.29	0.01								
4	4.50	6.55	2.52	1.60	1.54	0.48	0.88	0.12	0.65	0.06	0.39	0.02	0.27	0.01						
5	5.63	9.91	3.16	2.42	1.93	0.73	1.10	0.19	0.81	0.09	0.49	0.03	0.34	0.01						
6	6.75	13.89	3.79	3.40	2.31	1.02	1.32	0.26	0.97	0.12	0.58	0.04	0.41	0.02	0.26	0.01				
7	7.88	18.48	4.42	4.52	2.70	1.36	1.54	0.35	1.13	0.16	0.68	0.05	0.48	0.02	0.31	0.01				
8	9.01	23.66	5.05	5.79	3.08	1.74	1.76	0.45	1.29	0.21	0.78	0.06	0.55	0.03	0.35	0.01				
9	10.13	29.43	5.68	7.20	3.47	2.17	1.99	0.56	1.45	0.26	0.88	0.08	0.61	0.03	0.40	0.01				
10	11.26	35.77	6.31	8.75	3.85	2.63	2.21	0.68	1.61	0.32	0.97	0.09	0.68	0.04	0.44	0.01				
12	13.51	50.14	7.57	12.27	4.62	3.69	2.65	0.95	1.94	0.44	1.17	0.13	0.82	0.05	0.53	0.02				
14	15.76	66.71	8.84	16.32	5.39	4.91	3.09	1.26	2.26	0.59	1.36	0.17	0.96	0.07	0.62	0.03				
16	18.01	85.42	10.10	20.90	6.17	6.29	3.53	1.62	2.58	0.76	1.56	0.22	1.09	0.09	0.71	0.03	0.41	0.01		
18	20.26	106.24	11.36	25.99	6.94	7.82	3.97	2.01	2.90	0.94	1.75	0.28	1.23	0.12	0.79	0.04	0.46	0.01		
20			12.62	31.59	7.71	9.51	4.41	2.45	3.23	1.14	1.95	0.33	1.36	0.14	0.88	0.05	0.51	0.01		
22			13.89	37.69	8.48	11.35	4.85	2.92	3.55	1.37	2.14	0.40	1.50	0.17	0.97	0.06	0.56	0.02		
24			15.15	44.28	9.25	13.33	5.29	3.43	3.87	1.60	2.34	0.47	1.64	0.20	1.06	0.07	0.61	0.02		
26			16.41	51.36	10.02	15.46	5.74	3.98	4.20	1.86	2.53	0.54	1.77	0.23	1.15	0.08	0.66	0.02		
28			17.67	58.91	10.79	17.73	6.18	4.56	4.52	2.13	2.73	0.62	1.91	0.26	1.23	0.09	0.71	0.02		
30			18.94	66.94	11.56	20.15	6.62	5.19	4.84	2.42	2.92	0.71	2.05	0.30	1.32	0.10	0.77	0.03		
32					12.33	22.71	7.06	5.85	5.16	2.73	3.12	0.80	2.18	0.34	1.41	0.12	0.82	0.03	0.36	0.00
34					13.10	25.41	7.50	6.54	5.49	3.06	3.31	0.89	2.32	0.38	1.50	0.13	0.87	0.03	0.38	0.00
36					13.87	28.24	7.94	7.27	5.81	3.40	3.51	0.99	2.46	0.42	1.59	0.14	0.92	0.04	0.40	0.01
38					14.64	31.22	8.38	8.04	6.13	3.76	3.70	1.10	2.59	0.46	1.68	0.16	0.97	0.04	0.43	0.01
40					15.41	34.33	8.82	8.84	6.46	4.13	3.89	1.21	2.73	0.51	1.76	0.18	1.02	0.05	0.45	0.01
42					16.18	37.58	9.26	9.67	6.78	4.52	4.09	1.32	2.87	0.56	1.85	0.19	1.07	0.05	0.47	0.01
44					16.95	40.96	9.71	10.54	7.10	4.93	4.28	1.44	3.00	0.61	1.94	0.21	1.12	0.06	0.49	0.01
46					17.73	44.47	10.15	11.45	7.42	5.35	4.48	1.57	3.14	0.66	2.03	0.23	1.17	0.06	0.52	0.01
48					18.50	48.12	10.59	12.39	7.75	5.79	4.67	1.69	3.28	0.71	2.12	0.25	1.23	0.07	0.54	0.01
50					19.27	51.90	11.03	13.36	8.07	6.25	4.87	1.83	3.41	0.77	2.20	0.27	1.28	0.07	0.56	0.01
55							12.13	15.94	8.88	7.45	5.36	2.18	3.75	0.92	2.42	0.32	1.40	0.08	0.62	0.01
60							13.24	18.72	9.68	8.75	5.84	2.56	4.09	1.08	2.65	0.37	1.53	0.10	0.67	0.01
65							14.34	21.72	10.49	10.15	6.33	2.97	4.44	1.25	2.87	0.43	1.66	0.11	0.73	0.02
70							15.44	24.91	11.30	11.65	6.82	3.41	4.78	1.43	3.09	0.50	1.79	0.13	0.79	0.02
75							16.54	28.31	12.10	13.23	7.30	3.87	5.12	1.63	3.31	0.56	1.91	0.15	0.84	0.02
80							17.65	31.90	12.91	14.91	7.79	4.36	5.46	1.84	3.53	0.63	2.04	0.17	0.90	0.02
85									13.72	16.69	8.28	4.88	5.80	2.06	3.75	0.71	2.17	0.19	0.95	0.03
90									14.52	18.55	8.76	5.43	6.14	2.29	3.97	0.79	2.30	0.21	1.01	0.03
95									15.33	20.50	9.25	6.00	6.48	2.53	4.19	0.87	2.42	0.23	1.07	0.03
100									16.14	22.55	9.74	6.59	6.82	2.78	4.41	0.96	2.55	0.25	1.12	0.03
110											10.71	7.87	7.51	3.31	4.85	1.14	2.81	0.30	1.23	0.04
120											11.68	9.24	8.19	3.89	5.29	1.34	3.06	0.36	1.35	0.05
130											12.66	10.72	8.87	4.52	5.73	1.56	3.32	0.41	1.46	0.06
140											13.63	12.30	9.55	5.18	6.17	1.79	3.57	0.47	1.57	0.06
150											14.61	13.97	10.24	5.89	6.61	2.03	3.83	0.54	1.68	0.07
160											15.58	15.75	10.92	6.63	7.05	2.29	4.08	0.61	1.79	0.08
170													11.60	7.42	7.50	2.56	4.34	0.68	1.91	0.09
180													12.28	8.25	7.94	2.85	4.59	0.75	2.02	0.10
190													12.97	9.12	8.38	3.15	4.85	0.83	2.13	0.11
200													13.65	10.03	8.82	3.46	5.11	0.92	2.24	0.12
220													15.01	11.96	9.70	4.13	5.62	1.09	2.47	0.15
240													16.38	14.06	10.58	4.85	6.13	1.28	2.69	0.17
260															11.46	5.63	6.64	1.49	2.92	0.20
280															12.35	6.46	7.15	1.71	3.14	0.23
300															13.23	7.34	7.66	1.94	3.37	0.26
320															14.11	8.27	8.17	2.19	3.59	0.30
340															14.99	9.25	8.68	2.45	3.81	0.33
360															15.87	10.29	9.19	2.72	4.04	0.37
380																	9.70	3.01	4.26	0.41
400																	10.21	3.31	4.49	0.45
420																	10.72	3.62	4.71	0.49
440																	11.23	3.95	4.94	0.53
460																	11.74	4.28	5.16	0.58
480																	12.25	4.64	5.38	0.63
500																	12.76	5.00	5.61	0.68

Notes: Shaded area represents velocities over 5 fps. Use with caution where water hammer is a concern.

FRICITION LOSS CHARTS

POLYETHYLENE PLASTIC PIPE ID CONTROLLED

PE 3408 ASTM D 2239 C=40 • PSI loss per 100 ft. of pipe

Nominal Size Avg. Wall	½" 0.622		¾" 0.824		1" 10.49		1¼" 1.380		1½" 1.610		2" 2.067		2½" 2.469		3" 3.068		4" 4.026	
	Velocity FPS	PSI Loss	Velocity FPS	PSI Loss	Velocity FPS	PSI Loss	Velocity FPS	PSI Loss	Velocity FPS	PSI Loss	Velocity FPS	PSI Loss	Velocity FPS	PSI Loss	Velocity FPS	PSI Loss	Velocity FPS	PSI Loss
1	1.05	0.49	0.60	0.12	0.37	0.04	0.21	0.01	0.16	0.00								
2	2.11	1.76	1.20	0.45	0.74	0.14	0.43	0.04	0.31	0.02	0.19	0.01						
3	3.16	3.73	1.80	0.95	1.11	0.29	0.64	0.08	0.47	0.04	0.29	0.01						
4	4.22	6.35	2.40	1.62	1.48	0.50	0.86	0.13	0.63	0.06	0.38	0.02	0.27	0.01				
5	5.27	9.60	3.00	2.44	1.85	0.76	1.07	0.20	0.79	0.09	0.48	0.03	0.33	0.01				
6	6.33	13.46	3.61	3.43	2.22	1.06	1.29	0.28	0.94	0.13	0.57	0.04	0.40	0.02	0.26	0.01		
7	7.38	17.91	4.21	4.56	2.60	1.41	1.50	0.37	1.10	0.18	0.67	0.05	0.47	0.02	0.30	0.01		
8	8.44	22.93	4.81	5.84	2.97	1.80	1.71	0.47	1.26	0.22	0.76	0.07	0.54	0.03	0.35	0.01		
9	9.49	28.52	5.41	7.26	3.34	2.24	1.93	0.59	1.42	0.28	0.86	0.08	0.60	0.03	0.39	0.01		
10	10.55	34.67	6.01	8.82	3.71	2.73	2.14	0.72	1.57	0.34	0.95	0.10	0.67	0.04	0.43	0.01		
12			7.21	12.37	4.45	3.82	2.57	1.01	1.89	0.48	1.15	0.14	0.80	0.06	0.52	0.02		
14			8.41	16.45	5.19	5.08	3.00	1.34	2.20	0.63	1.34	0.19	0.94	0.08	0.61	0.03		
16			9.61	21.07	5.93	6.51	3.43	1.71	2.52	0.81	1.53	0.24	1.07	0.10	0.69	0.04	0.40	0.01
18			10.82	26.21	6.67	8.10	3.86	2.13	2.83	1.01	1.72	0.30	1.20	0.13	0.78	0.04	0.45	0.01
20			12.02	31.85	7.42	9.84	4.28	2.59	3.15	1.22	1.91	0.36	1.34	0.15	0.87	0.05	0.50	0.01
22					8.16	11.74	4.71	3.09	3.46	1.46	2.10	0.43	1.47	0.18	0.95	0.06	0.55	0.02
24					8.90	13.79	5.14	3.63	3.78	1.72	2.29	0.51	1.61	0.21	1.04	0.07	0.60	0.02
26					9.64	16.00	5.57	4.21	4.09	1.99	2.48	0.59	1.74	0.25	1.13	0.09	0.65	0.02
28					10.38	18.35	6.00	4.83	4.41	2.28	2.67	0.68	1.87	0.28	1.21	0.10	0.70	0.03
30					11.12	20.85	6.43	5.49	4.72	2.59	2.86	0.77	2.01	0.32	1.30	0.11	0.76	0.03
32					11.86	23.50	6.86	6.19	5.04	2.92	3.06	0.87	2.14	0.36	1.39	0.13	0.81	0.03
34					12.61	26.29	7.28	6.92	5.35	3.27	3.25	0.97	2.28	0.41	1.47	0.14	0.86	0.04
36							7.71	7.69	5.67	3.63	3.44	1.08	2.41	0.45	1.56	0.16	0.91	0.04
38							8.14	8.50	5.98	4.02	3.63	1.19	2.54	0.50	1.65	0.17	0.96	0.05
40							8.57	9.35	6.30	4.42	3.82	1.31	2.68	0.55	1.73	0.19	1.01	0.05
42							9.00	10.24	6.61	4.83	4.01	1.43	2.81	0.60	1.82	0.21	1.06	0.06
44							9.43	11.16	6.93	5.27	4.20	1.56	2.94	0.66	1.91	0.23	1.11	0.06
46							9.86	12.12	7.24	5.72	4.39	1.70	3.08	0.71	1.99	0.25	1.16	0.07
48							10.28	13.11	7.56	6.19	4.58	1.84	3.21	0.77	2.08	0.27	1.21	0.07
50							10.71	14.14	7.87	6.68	4.77	1.98	3.35	0.83	2.17	0.29	1.26	0.08
55							11.78	16.87	8.66	7.97	5.25	2.36	3.68	0.99	2.38	0.35	1.38	0.09
60							12.85	19.82	9.44	9.36	5.73	2.77	4.02	1.17	2.60	0.41	1.51	0.11
65									10.23	10.86	6.21	3.22	4.35	1.36	2.82	0.47	1.64	0.13
70									11.02	12.45	6.68	3.69	4.69	1.55	3.03	0.54	1.76	0.14
75									11.81	14.15	7.16	4.19	5.02	1.77	3.25	0.61	1.89	0.16
80									12.59	15.95	7.64	4.73	5.35	1.99	3.47	0.69	2.01	0.18
85									13.38	17.84	8.12	5.29	5.69	2.23	3.68	0.77	2.14	0.21
90											8.59	5.88	6.02	2.48	3.90	0.86	2.27	0.23
95											9.07	6.50	6.36	2.74	4.12	0.95	2.39	0.25
100											9.55	7.15	6.69	3.01	4.33	1.05	2.52	0.28
110											10.50	8.53	7.36	3.59	4.77	1.25	2.77	0.33
120											11.46	10.02	8.03	4.22	5.20	1.47	3.02	0.39
130											12.41	11.62	8.70	4.89	5.63	1.70	3.27	0.45
140											13.37	13.33	9.37	5.61	6.07	1.95	3.52	0.52
150													10.04	6.38	6.50	2.22	3.78	0.59
160													10.71	7.19	6.94	2.50	4.03	0.67
170													11.38	8.04	7.37	2.79	4.28	0.74
180													12.05	8.94	7.80	3.11	4.53	0.83
190													12.72	9.88	8.24	3.43	4.78	0.92
200													13.39	10.87	8.67	3.78	5.03	1.01
220															9.54	4.50	5.54	1.20
240															10.40	5.29	6.04	1.41
260															11.27	6.14	6.54	1.64
280															12.14	7.04	7.05	1.88
300															13.00	8.00	7.55	2.13
320															13.87	9.02	8.05	2.40
340																	8.56	2.69
360																	9.06	2.99
380																	9.57	3.30
400																	10.07	3.63
420																	10.57	3.98
440																	11.08	4.33
460																	11.58	4.71
480																	12.08	5.09
500																	12.59	5.49

Notes: Shaded area represents velocities over 5 fps. Use with caution where water hammer is a concern.

FRICION LOSS CHARTS

TABLE OF APPROXIMATE PRESSURE LOSSES FOR PIPE FITTINGS

Steel Fitting Type	½"	¾"	1"	1¼"	1½"	2"	2½"	3"	4"	6"	8"
Coupling	0.6	0.8	1	1.2	1.5	2	2.5	3	4	6	8
Run of St. Tee	1	1	1.5	2	2	2.5	3	4	5	7	10
Tee, Side Outlet	3	4.5	5	7	9	11	13	16	20	31	42
Tee, Run Reduced ½"	1.5	2.5	3	4	5	6	7	8	12	16	20
Elbow, 90°	1.5	2.5	3	4	5	6	7	8	12	16	20
Elbow, 45°	0.75	1	1.3	1.7	2	2.5	3	3.5	5	7.5	10
Corporation Stop	9	9	9	9	9	9					
Curb Stop	6	6	7	7	8	8					

Plastic IPS or Copper Fitting Type	½"	¾"	1"	1¼"	1½"	2"	2½"	3"	4"	6"	8"
Coupling	1.5	2.5	3.0	3.0	4.0	6.0	7.0	8.0	11.0	18.0	24.0
Run of St. Tee	2.5	3.0	4.0	5.0	6.0	8.0	9.0	11.0	15.0	21.0	28.0
Tee, Side Outlet	7.0	9.0	12.0	15.0	18.0	24.0	30.0	36.0	45.0	70.0	90.0
Tee, Run Reduced ½"	3.5	4.5	6.0	8.0	9.0	11.0	14.0	17.0	24.0	34.0	45.0
Elbow, 90°	3.5	4.5	6.0	8.0	9.0	11.0	14.0	17.0	24.0	34.0	45.0
Elbow, 34°	1.5	2.0	3.0	3.5	4.0	5.0	7.0	8.0	10.0	16.0	20.0

To use this chart, multiply the approximate "equivalent feet of pipe" value by the proper pipe pressure loss per 100 feet rating, then divide by 100. The result is the fitting loss in PSI.

Notes:

It is recommended that the above chart be used only when the manufacturers recommended pressure loss values are not available.

ACCESSORY PRESSURE LOSS CHARTS

HCV PRESSURE LOSS CHART

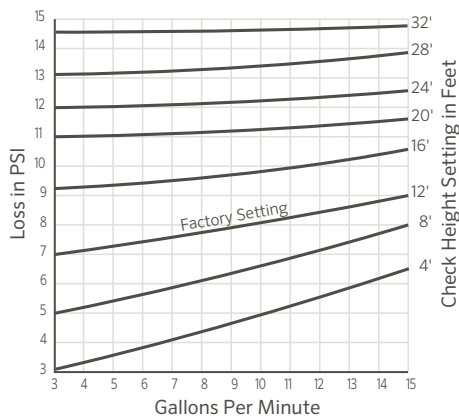

SWING JOINT FRICTION LOSS

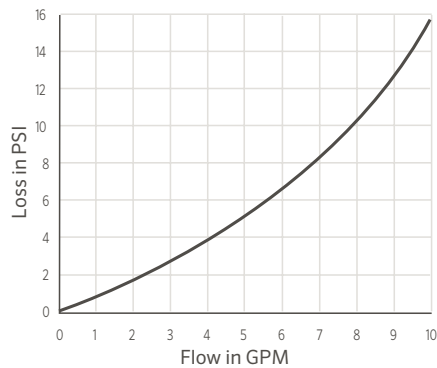

WIRE DATA

STANDARD ANNEALED COPPER AT 20° C

American Wire Gauge	Metric Wire Gauge	Diameter (Mils)	Diameter (mm)	Resistance (Per mft Ohms)	Resistance (Per km Ohms)
1		289.3	7.348	0.9239	0.4065
	7		7		0.448
2		257.6	6.543	0.1563	0.5128
	6		6		0.6098
3		229.4	5.827	0.1971	0.6466
4		204.3	5.189	0.2485	0.8152
	5		5		0.08781
5		181.9	4.62	0.3134	1.028
	4.5		4.5		1.084
6		162	4.115	0.3952	1.297
	4		4		1.372
7		144.3	3.665	0.4981	1.634
	3.5		3.5		1.792
8		128.5	3.264	0.6281	2.061
	3		3		2.439
9		114.4	2.906	0.7925	2.6
10		101.9	2.588	0.9988	3.277
	2.5		2.5		3.512
11		90.7	2.3	1.26	4.14
12		80.8	2.05	1.59	5.21
	2		2		5.49
13		72	1.83	2	6.56
	1.8		1.8		6.78
14		64.1	1.63	2.52	8.28
	1.6		1.6		8.58
15		57.1	1.45	3.18	10.4
	1.4		1.4		11.2
16		50.8	1.29	4.02	13.2
	1.2		1.2		15.2
17		45.3	1.15	5.05	16.6
18		40.3	1.02	6.39	21
	1		1		22
19		35.9	0.912	8.05	26.4
	0.9		0.9		27.1
20		32	0.813	10.1	33.2

WIRE SIZING

REQUIRED INFORMATION

- Actual one-way length of wire between the controllers and the power source or the controllers and valves
- Allowable voltage loss along the wire circuit
- Accumulative current flowing through the wire section being sized in amperes

RESISTANCE IS CALCULATED USING THIS FORMULA:

$$R = \frac{1000 \times AVL}{2L \times I}$$

R = Maximum Allowable Resistance of wire in ohms per 1,000 ft.

AVL = Allowable voltage loss

L = Wire length (one way)

I = Inrush current

AVL for controller power wire sizing is calculated by subtracting the minimum operating voltage required by the controller from the minimum available voltage at the power source.

AVL for valve wire sizing is calculated by subtracting minimum solenoid operating voltage from controller output voltage. This number will vary depending on the manufacturer and in some cases with line pressure.

VALVE WIRE SIZING EXAMPLE

Given: The distance from the controller to the valve is 1,800 ft. The controller output is 24 V. The valve has a minimum operating voltage of 20 V and an inrush current of 370 mA (0.37 A).

$$R = \frac{1000 \times 4}{2(1800) \times 0.37}$$

$$R = \frac{4000}{1332}$$

R = 3.00 ohms/1,000 ft.

So, wire resistance can not exceed 3.00 ohms per 1,000 ft. Now go to table #1 and select the proper wire size. Since 16 gauge wire has more resistance than 3.00 ohms per 1,000 ft., choose 14 gauge wire.

Table 2 is a quick reference and is set up to provide maximum wire runs given the information at the bottom of the table.

TABLE 1 - RESISTANCE OF COPPER WIRE

Wire Size (AWG)	Resistance at 20° C (68° F) (ohms per 1,000 ft.)
18	6.39
16	4.02
14	2.52
12	1.59
10	1
8	0.63
6	0.4
4	0.25

TABLE 2 - VALVE WIRE SIZING

Ground Wire	Control Wire						
	18	16	14	12	10	8	6
18	850	1040	1210	1350	1460	1540	1590
16	1040	1340	1650	1920	2150	2330	2440
14	1210	1650	2150	2630	3080	3450	3700
12	1350	1920	2630	3390	4170	4880	5400
10	1460	2150	3080	4170	5400	6670	7690
8	1540	2330	3450	4880	6670	8700	10530
6	1590	2440	3700	5400	7690	10530	13330

Notes:

Maximum one-way distance in feet between controller and valve
 Heavy-duty solenoid: 24 VAC, 370 mA inrush current, 190 mA holding current, 60 cycles;
 475 mA inrush current, 230 mA holding current, 50 cycles

ADDITIONAL DATA

WIRE SIZE REFERENCE CHART

Wire Size (AWG)	½	¾	1	1¼	1½	2	2½	3	3½	4	5	6	Wire Size (AWG)
18	6	12	20	35	49	80	110	175					18
16	5	10	16	30	42	67	97	150					16
14	4	6	10	18	25	40	56	88	120	150			14
12	3	5	7	15	20	33	50	75	102	130	205		12
10	1	3	6	13	16	27	40	63	85	110	170		10
8	1	2	4	6	9	16	25	35	50	65	105	150	8
6	1	1	3	3	5	10	15	22	32	40	63	92	6
4		1	1	2	4	7	10	16	24	30	48	70	4
2		1	1	2	2	5	9	12	18	22	36	54	2
0			1	1	2	3	5	8	12	15	24	36	0
00			1	1	1	2	4	7	10	14	21	31	00
000				1	1	2	3	6	8	11	18	26	000
0000				1	1	1	2	5	7	10	15	22	0000

Notes:

Approximate number of wires to be installed in conduit or tubing.
Maximum number of wires in conduit or sleeving.

ESTIMATING PIPE SIZE

Nominal Pipe Size	Approximate String Length in Inches		
	Copper Pipe	Galvanized (Sch. 40 Steel)	PVC Pipe
½"	2"	2⅝"	2⅝"
⅝"	2⅜"		
¾"	2¾"	3⅝"	3⅝"
1"	3½"	4⅞"	4⅞"
1¼"	4⅞"	5⅜"	5⅜"
1½"	5⅞"	6"	6"
2"	6¾"	7⅞"	7⅞"

Notes:

To determine the nominal size of a pipe, wrap a string around the pipe and compare its length to the chart above.

CLIMATE ETp TABLE

Climate*	Inches Daily
Cool Humid	0.10 to 0.15
Cool Dry	0.15 to 0.20
Warm Humid	0.15 to 0.20
Warm Dry	0.20 to 0.25
Hot Humid	0.20 to 0.30
Hot Dry	0.30 to 0.45

Notes:

- * Cool = under 70 °F as an average mid-summer high
- * Warm = between 70° and 90° F as mid-summer highs
- * Hot = over 90°
- * Humid = over 50% as average mid-summer relative humidity (dry=under 50%)

STATEMENT OF WARRANTY

Hunter Industries Incorporated (“Hunter”) warrants the following products to be free of defects in materials or workmanship under normal use for a period of one (1) year from the original date of manufacture: SRM family, and Micro Sprays. Hunter warrants the following products to be free of defects in materials or workmanship under normal use for a period of two (2) years from the original date of manufacture: PGP®-ADJ, PGJ, MP Rotator family, PS Ultra family, Spray Nozzles, PCN, PCB, AFB, PGV family, SRV, X-Core family, Pro-C family, ROAM, NODE, WVP, WVS, ACZ, PCZ, PSR, HCV, SJ, FLEXsg, HSBE family, RZWS, and ET System. Hunter warrants the following products to be free of defects in materials or workmanship under normal use for a period of five (5) years from the original date of manufacture: ROAM XL, PGP Ultra family, I-20, I-25, I-35, I-40, I-60 and I-90 families, Pro-Spray® family, Pro-Spray® PRS30 family, and Pro-Spray® PRS40 family, I-Core/Dual family and ACC controller families, ROAM XL, ICD Decoder Products, ICR Remotes, IMMS™ Central Control Products, “Clik” Sensors, Solar-Sync, HQ, ICV and IBV valves, ICZ and PLD tubing, Eco-Mat, ST System Rotors and Accessories. If used for agriculture applications, Hunter limits the warranty for its spray, rotator and rotor products to a period of one (1) year from original date of manufacture. This agriculture limitation supersedes all other warranties expressed or implied. Hunter warrants the battery life of the Wireless Rain-Clik and Wireless Solar Sync sensors for 10 years. If a defect in a Hunter product is discovered during the applicable warranty period, Hunter will repair or replace, at its option, the product or the defective part. This warranty does not extend to repairs, adjustments, or replacement of a Hunter product or part that results from misuse, negligence, alteration, modification, tampering, or improper installation and/or maintenance of the product. This warranty extends only to the original installer of the Hunter product. If a defect arises in a Hunter product or part during the warranty period, you should contact your local Hunter Authorized Distributor.

HUNTER’S OBLIGATION TO REPAIR OR REPLACE ITS PRODUCTS AS SET FORTH ABOVE IS THE SOLE AND EXCLUSIVE WARRANTY SET FORTH BY HUNTER. THERE ARE NO OTHER WARRANTIES, EXPRESSED OR IMPLIED, INCLUDING WARRANTIES OF MERCHANTABILITY AND FITNESS FOR A PARTICULAR PURPOSE. HUNTER WILL NOT BE LIABLE TO ANY PARTY IN STRICT LIABILITY, TORT, CONTRACT, OR ANY OTHER MANNER FOR DAMAGES CAUSED OR CLAIMED TO BE CAUSED AS A RESULT OF ANY DESIGN OR DEFECT IN HUNTER’S PRODUCTS, OR FOR ANY SPECIAL, INCIDENTAL OR CONSEQUENTIAL DAMAGES OF ANY NATURE.

If you have any questions concerning the warranty or its application, please email HunterTechnicalSupport@hunterindustries.com.

ASAE CERTIFICATION STATEMENT

Hunter Industries Incorporated certifies that pressure, flow rate, and radius data for these products were determined and listed in accordance with ASAE Standard S398.1, Procedure for Sprinkler Testing and Performance Reporting, and are representative of performance of production sprinklers at the time of publication. Actual product performance may differ from the published specifications due to normal manufacturing variations and sample selection. All other specifications are solely the recommendation of Hunter Industries Incorporated.



HUNTER: *Built on Innovation*



Helping our customers succeed is what drives us. While our passion for innovation and engineering is built into everything we do, it is our commitment to exceptional support that we hope will keep you in the Hunter family of customers for years to come.

A handwritten signature in black ink, reading "Richard E. Hunter".

Richard E. Hunter, CEO of Hunter Industries

Website hunterindustries.com | **Customer Support** +1 760-744-5240 | **Technical Service** +1 760-591-7383

USA

1940 Diamond Street
San Marcos, California 92078, USA
TEL: +1 760-744-5240
hunterindustries.com

MEXICO MANUFACTURING

ISO 2001:2008 Certified
Calle Nordika #8615
Parque Industrial Nordika
Tijuana, B.C., Mexico CP 22709
52 64-903-1300

EUROPE

Avda. Diagonal 523, 5º- 2º
Edificio Atalaya
08029 Barcelona, Spain
TEL: 34 9-34-94-88-81

AUSTRALIA

8 The Parade West
Kent Town, South Australia 5067
TEL: 61 8-8363-3599
FAX: 61 8-8363-3687

MIDDLE EAST

P.O. Box 211303
Amman, 11121, Jordan
TEL: 962 6-515-2882

CHINA

B1618, Huibin Office Bldg.
No.8, Beichen Dong Street
Beijing 100101, China
TEL/FAX: 86 10-84975146